

RACE TECH

FORK COMPRESSION AND REBOUND GOLD VALVE INSTALLATION

FK code

DIRT 35C/30R SFF

TOOLS REQUIRED: (In addition to those required for fork disassembly.) In-lb torque wrench that accurately measures 0 to 50 in-lbs (0.58 kgf-m), 10mm wrench, Fine flat file, Hi-strength Loctite (included), Metric calipers, Metric micrometer 0-25mm.

NOTE: Many riders require different fork springs.

DISASSEMBLY COMPRESSION

1 **Completely disassemble and clean your front forks. If you are unfamiliar with this process, STOP! Do not proceed. Seek out a qualified suspension technician to complete the installation.**

NOTE: Twin-Chamber Forks are slightly different than open cartridges. When removing the damping rod from the cartridge carefully inspect the thread on the end of the damping rod for sharp edges. **These edges can tear the shaft seal.** As a precaution pack the thread with heavy grease before you slide the damping rod out.

2 **Remove the nut.** When disassembling the compression valve for the first time, **the thread above the nut must be filed off flat.** Lightly deburr the end of the thread.

3 **Disassemble the valving stack.** Lay out the pieces in the order they come off the shaft. Clean and inspect all the original parts. Be careful to maintain the original order and orientation of the parts. (You may need some of the original valving for spacing purposes, do not discard.)

COMPRESSION VALVING

4 **To obtain custom valving settings visit [racetech](#), go to Digital Valving Search (DVS), insert your Access Code (printed on the top of this page), input your personal specifications and print the custom setup information.**

5 Once you have selected your valving **begin assembling the valve.** If your model has a **Lo-Speed Valve (LSV)** refer to figure 2 and the last page for the LSV Valving Chart. Your configuration may be slightly different. Assemble the LSV according to the DVS Setup sheet. If you don't have a LSV Place the original Base Plate on the shaft of the compression valve and refer to figure 1.

5a **Single Stage Stacks** - A Single Stage Stack is a two-part stack made up of a **combination of a Lo-Speed Stack and a Hi-Speed Stack with NO Crossover.** Put the valving on the shaft in the order listed, starting with the smallest diameter shim of the Hi-

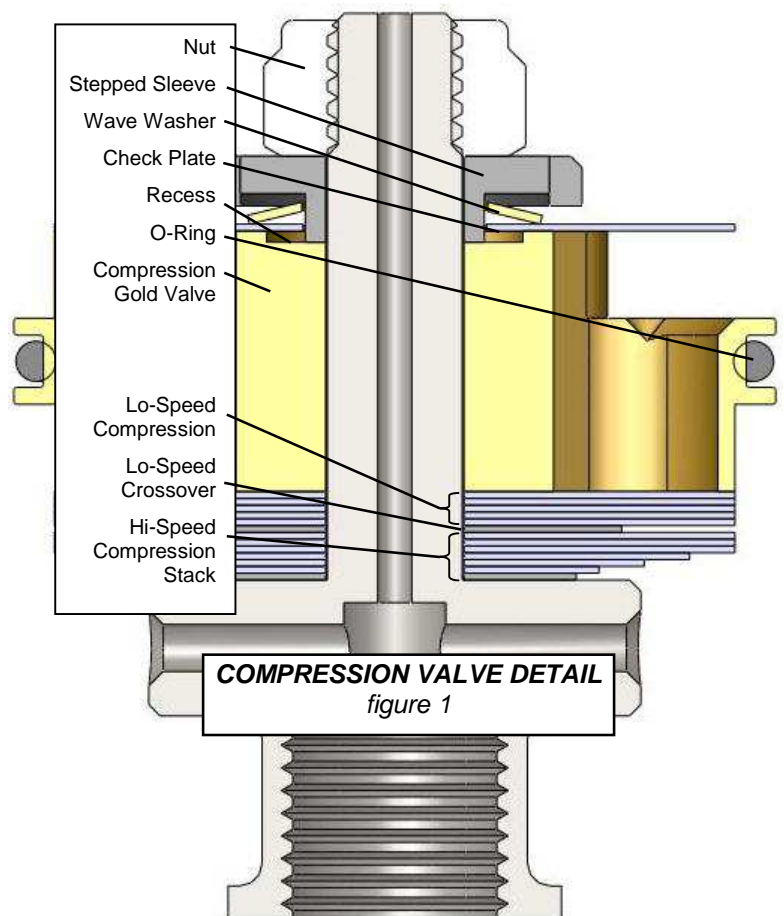

Speed Stack. Then the Lo-Speed Stack gets placed on top of the Hi-Speed Stack. **You will not use a Crossover.**

- 5b **Two Stage Stacks (shown in figure 1)** - For Two Stage Stacks the total valving stack is made up of a combination of a **Lo-Speed Stack, a Lo-Speed Crossover and a Hi-Speed Stack**. Put the valving on the shaft in the order listed, starting with the smallest diameter shim of the Hi-Speed Stack. Then the Lo-Speed Crossover gets placed on top of the Hi-Speed Stack, then the Lo-Speed Stack ends up closest to the Gold Valve.
- 6 **Place the Gold Valve on the shaft** with the recess on the piston facing up. Make sure the o-ring is on the Gold Valve.
- 7 **Place the check valve plate (large ID washer) and the wave washer spring on the shaft.** Next install the Stepped Sleeve and the nut. Be sure the Check Plate is free to move on the Sleeve before you tighten the nut.
- 8 **Check to see the total valve stack thickness is correct. WARNING: You must be very sure that the nut does not run out of thread onto the straight part of the shaft.** If it does, the nut will not tighten down on the valving. This will cause incorrect operation or the nut will come off. This is a critical part of the installation. To get the proper total valve stack thickness you may need to place some of the original shims on the shaft just after the base plate. NOTE: Any shims added must be larger in diameter than the last shim in the stack. **Be sure the nut is fully engaging the thread!**
- 9 **Make sure the check valve plate (large ID washer) is free** and can move up and down against the wave washer spring.
- 10 **CAUTION! The thread can be damaged without extreme care. To install the nut you must use Loctite. The 6mm nut (10mm wrench) must be torqued with a torque wrench to 30 in-lbs (0.35 kgf-m), **NO MORE!** Do not take this step lightly.**
- 11 **Inspect your work.** For two stage stacks, hold the compression stack up to the light and look for the gap at the cross-over between the lo-speed and hi-speed stack (the small shim near the top of the stack). This gap should be visible, if it isn't, disassemble the stack and look for burrs to surface and/or dirt in the valving. Reassemble and check again.

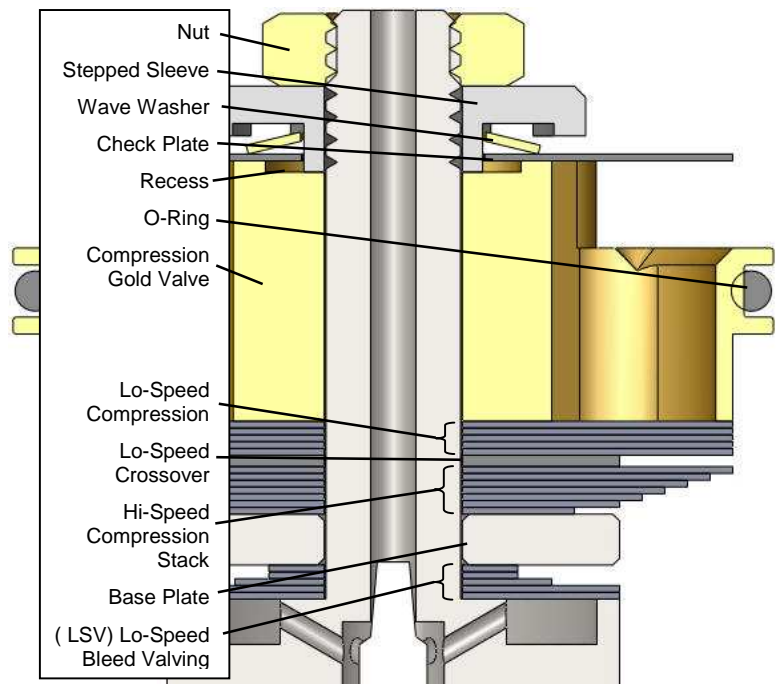
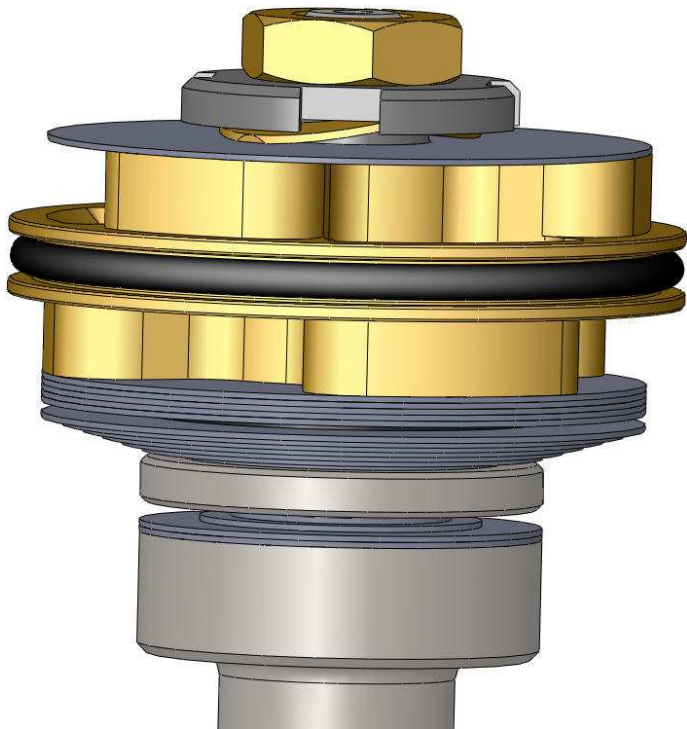

**COMPRESSION VALVE DETAIL
with LO-SPEED BLEED VALVE**
figure 2

BUILDING the COMPRESSION VALVING STACK - DIRT 3521

Welcome to the wonderful world of Gold Valving. To obtain your personal Custom Suspension Settings:

1. Log on to our website at [racetech](http://racetech.com)
2. Go to Digital Valving Search (DVS)
3. Input your Access Code when prompted (your Code is printed on top of page 1 of these instructions)
4. Input your personal specifications
5. Print your DVS Custom Suspension Setup Sheet

Once you have your valving settings, build your compression valving stacks.

Single Stage - made up of a Lo-Speed Stack and a Hi-Speed Stack – **NO Crossover**.

Two Stage - made up of a Lo-Speed Stack, a Crossover Shim, and a Hi-Speed Stack.

Single Stage COMPRESSION EXAMPLE:

The **Total Compression Valving Stack** is:

cL1514 and cH17 only (no Crossover):

Starting from the Gold Valve piston face

Lo-Speed Stack – cL1514

(14) .15x30

Hi-Speed Stack – cH17

- (1) .15x28
- (1) .15x26
- (1) .15x24
- (1) .15x22
- (1) .15x20
- (1) .15x18

Two Stage COMPRESSION EXAMPLE:

The **Total Compression Valving Stack** is:

cL1510, cLX1020 and cH18:

Starting from the Gold Valve piston face

Lo-Speed Stack – cL1510

(10) .15x30

Lo-Speed Crossover – cLX1020

(1) .10x20

Hi-Speed Stack – cH18

- (1) .15x28
- (1) .15x26
- (2) .15x24
- (2) .15x22
- (2) .15x20
- (2) .15x18

NOTE: All measurements are metric (*for inches divide by 25.4*). The valving list starts at the piston face and goes towards the base plate. Valve specs are listed by (QUANTITY) THICKNESS x DIAMETER. A number in parentheses means quantity. If there is no number in parenthesis the quantity is one. Example: (2).15x30 means quantity two, 15 hundredths of a millimeter thick by 30 millimeters in diameter.

REBOUND DISASSEMBLY

- 12 **Remove the rebound rod from the cartridge.** When the damping rod is removed from the cartridge extreme care must be taken so the thread does not cut the shaft seal. Carefully deburr both ends of the thread and pack the thread with grease.
- 13 **Once the rod is removed, lightly file the peening off the end of the shaft that holds on the nut.** Remove the nut and **disassemble the valving stack.** Lightly deburr the end of the thread.

MID-VALVE & REBOUND VALVING

- 14 Select the Rebound and Mid-Valve Valving according to the DVS. Begin **assembling the Rebound Gold Valve.** Start with the Stock Check Spring Retainer and Check Spring, MV Clamp, Stock Sleeve, MV Packing Stack and Mid-Valve Stack. On some models Sleeve Extender Shims are required.

There are two critical components of the Mid-Valve; the stiffness of the Mid-Valve Stack itself and the "Float". The Float is controlled by a combination of the thickness of the MV Stack, the MV Packing Stack and the Sleeve Extender Shims.

- 15 Install the Rebound Gold Valve with the recess toward the Mid-Valve Stack.
- 16 Select the Rebound Valving. Install the Lo-Speed Rebound Stack, Crossover (if required) and Hi-Speed Rebound Stack, Base Plate and Nut. Use Loctite and torque the nut to 30 in-lbs (.35 kgf-m).

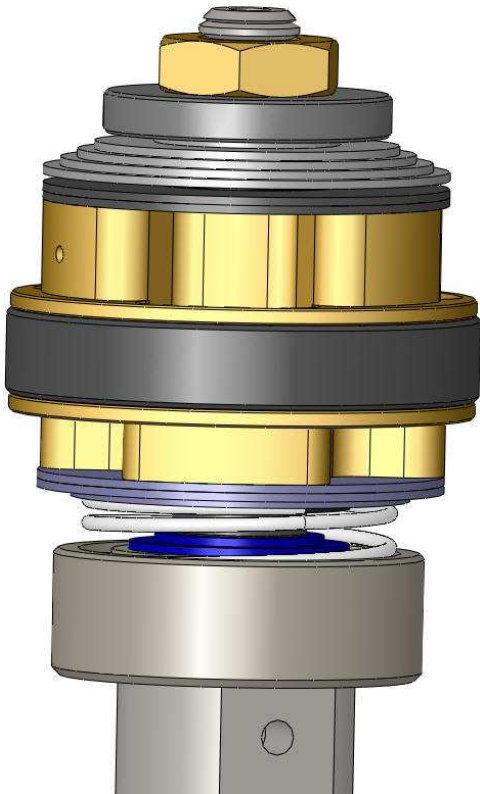
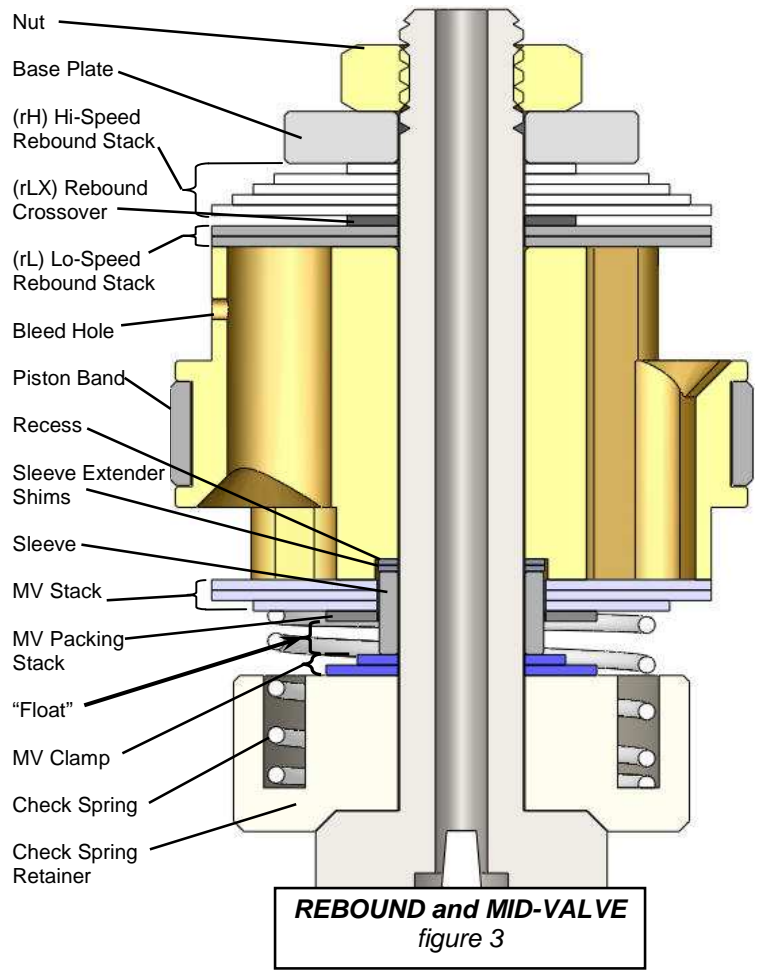

BUILDING the MID-VALVE

- DIRT 3026

MID-VALVE EXAMPLE:

The Total Mid-Valve Stack is MV36, MVP25 and MVC13.

Starting from the recessed Gold Valve piston face:

Mid-Valve Stack (8mm id) – MV36 – 1.05mm thick

- (3).15x26x8
- (1).15x24
- (1).15x22
- (1).15x20
- (1).15x18

MV Packing Stack (8mm id) – MVP25 - .25mm thick

- (1).15x15x8
- (1).10x15

Sleeve 6 id x 8 od – 2.40mm long (stock KX)

Sleeve Extender Shims – SE30 - .30mm thick

Recess Depth - 1.00mm

MV Clamp (6mm id) – MVC13

- (1).10x13x6
- (3).10x15x6

Float = Gap – Total Stack Thickness

Sleeve Length (stock KX)	2.40
Sleeve Extender Shims (KX)	.30
Recess (std Gold Valve)	— 1.00
Gap	= 1.70

MV Stack	1.05
MVP Packing	+ .25
Total Stack Thickness	= 1.30

Gap	1.70
Total Stack Thickness	— 1.30
Float	= .40

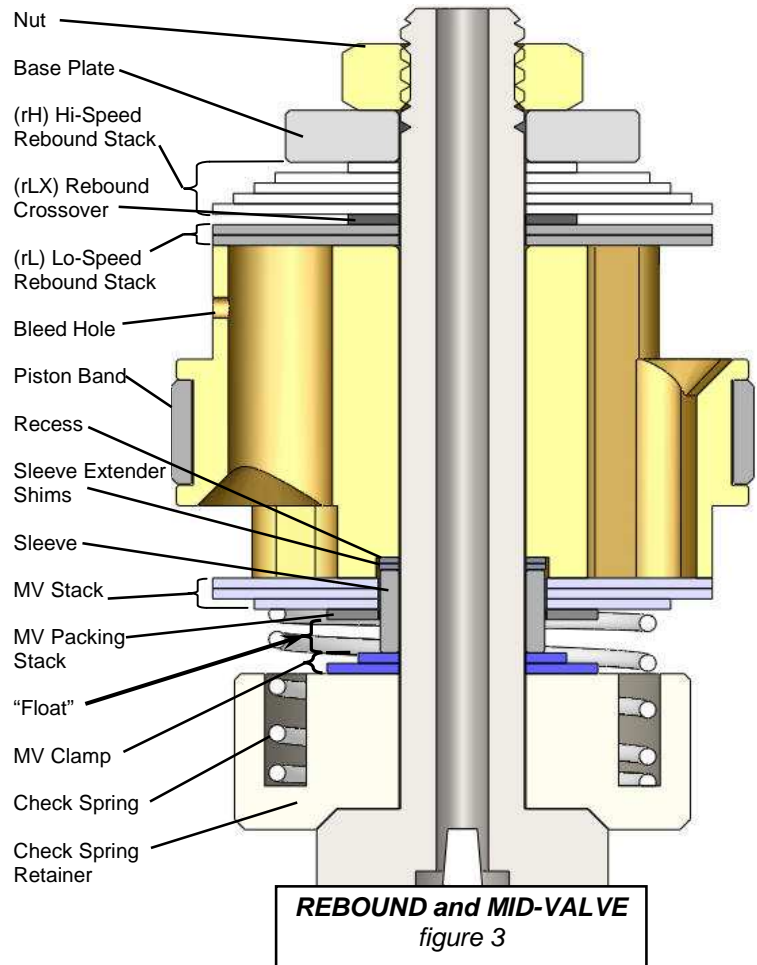

BUILDING the REBOUND STACK - DIRT 3026

Single Stage REBOUND EXAMPLE:

Lo-Speed	rL1006
Crossover	n/a
Hi-Speed	rH15

Starting from the flat Rebound Gold Valve piston face:

Lo-Speed Rebound Stack – rL1006

(6).10x26

Hi-Speed Rebound Stack – rH15

(1).10x24

(1).10x22

(1).10x20

(1).10x18

(1).10x16

(1).10x14

Two Stage REBOUND EXAMPLE:

Lo-Speed	rL1006
Crossover	rLX1015
Hi-Speed	rH15

Starting from the flat Rebound Gold Valve piston face:

Lo-Speed Rebound Stack – rL1006

(6).10x26

Lo-Speed Crossover – rLX1015

(1).10x15

Hi-Speed Rebound Stack – rH15

(1).10x24

(1).10x22

(1).10x20

(1).10x18

(1).10x16

(1).10x14

TUNING NOTES

- **Damping depends on vertical wheel velocity, not position in the stroke.**
- **If the forks feel too soft all the way through,** increase compression damping with the external adjuster. If that is not enough, change the compression stack internally.
- **The compression damping adjuster** controls the lowest speed damping and affects the entire range. NOTE: The closer to maximum damping (full clockwise) the more effect one click makes. In other words going from 3 to 2 out has a lot more effect than going from 14 to 13. Adjusters are numbered from all the way clockwise (the slowest or firmest setting).
- **If your valving needs to be stiffer, move to the right on the valving chart.** Moving to the right on the Low Speed Valving Chart will stiffen up low speed damping. This will improve bottoming resistance with minimum increase in harshness. Moving to the right on the High Speed Valving Chart will increase damping overall, making it stiffer through the entire speed range. If the forks are too firm, go the opposite direction, to the left.
- **Spring rate affects ride height, dive and bottoming.** Typical spring preload should be 3–5mm (0.1–0.3”).
- **Oil level can drastically alter bottoming resistance and only affects the last part of the travel** (near bottoming). If you like the action but the forks bottom too easily, raise your oil level by 10mm (0.4”).

FORK REASSEMBLY

- A1 **Install the damping rod into the cartridge.** Reassemble the forks according to the procedure in your manual. For Twin Chamber Forks the damping rod shaft seal must be protected. Pack the thread with heavy grease before you insert it into the cartridge.
- A2 **Fill and bleed the cartridge.** Before installing the compression assembly which includes the reservoir piston and cap make sure the oil level is high enough (100mm (4") down from the top of the cartridge with the damping rod fully extended). When you install the compression assembly it should require quite a bit of force when you push it in with your hand. Once you have tightened the cap compress the damping rod all the way. This will push out any extra oil from inside the cartridge and should be poured out of the holes in the top of the reservoir. When the damping rod is released it should extend all the way by itself. This indicates that there is enough oil inside the cartridge.
- A3 **Reassemble the forks.** Install the Cartridge Assembly and temporarily screw in the fork cap. Invert the fork. Compress the fork so the Damping Rod extends through the bottom of the fork.
- A4 Use Loctite on the damping rod thread at the Rebound Adjuster. **The Showa "D" Shaped Rod requires special attention.** Slide the "D" shaped Rebound Adjusting Rod on the Adjuster Bolt into the Damping Rod making sure it goes in all the way and registers on the Needle inside. When you screw on the Adjuster Bolt, hold the Adjusting Screw in one place with a screwdriver. This will keep the "D" Shaped Rod from rounding out.
- A5 **Torque the jam nut to manufacturers specs** (typically 16 to 21 ft-lbs [21.7 – 28.5 NM]). Consult shop manual for specs. Tighten the Adjuster Bolt into the Fork Bottom.
Unscrew the Fork Cap and add the proper oil volume to the outer chamber (consult the DVS). NOTE: The left and right legs have different oil levels. **Tighten the fork cap.**
- A6 **Adjust the compression and rebound adjusters, spring preload, and oil level** according to the DVS Setup Sheet.
- A7 **Install the forks on the bike.** When the forks are put on the bike it is very important to align the fork tubes. This is done by first tightening the axle all the way, then the tubes are aligned by pumping the forks up and down with the right-hand axle clamp loose. This will line the tubes up so they won't bind. Finally, tighten the axle clamp.