

RACE TECH

FORK GOLD VALVE INSTALLATION DIRT 34 & 35mm

FK code

TOOLS REQUIRED: (In addition to those required for fork disassembly.) In-lb torque wrench that accurately measures 0 to 50 in-lbs (0.58 kgf-m), Fine flat file, Hi-Strength Loctite (included), Metric calipers and micrometer.

NOTE: Many riders require different fork springs.

DISASSEMBLY

D1 **Completely disassemble and clean your front forks. If you are unfamiliar with this process, STOP! Do not proceed. Seek out a qualified suspension technician to complete the installation.**

NOTE: Twin Chamber Forks are slightly different than open cartridges. The Damping Rod Clip Tool (TFHP 01) easily holds the damping rod when taking off the bottom bolt. When removing the damping rod from the cartridge carefully inspect the thread on the end of the damping rod for sharp edges. **These edges can easily tear the shaft seal. File as necessary.** As a further precaution pack the thread with heavy grease before you slide the damping rod out. This is particularly true for early Showas with 12mm Damping Rods.

D2 **Remove the nut.** When disassembling the compression valve for the first time, **the thread above the nut must be filed off flat.** Lightly deburr the end of the thread.

D3 **Disassemble the valving stack.** Lay out the pieces in the order they come off the shaft. Clean and inspect all the original parts. Be careful to maintain the original order and orientation of the parts. (You may need some of the original valving for spacing purposes, do not discard.)

VALVING SELECTION

V1 To obtain custom valving settings visit [racetech](http://racetech.com), go to Digital Valving Search, insert your Access Code (printed on the top of the first page), input your personal specifications and print the custom setup information.

V2 Once you have selected your valving begin assembling the valve. If your model has a Lo-Speed Valve (LSV) refer to figures 2 and 3. Your configuration may be slightly different, possibly requiring two Base Plates. Assemble the LSV according to the DVS Setup sheet. If you don't have a LSV place the original Base Plate on the shaft.

V2a **Single Stage Stacks** - A Single Stage Stack is a two-part stack made up of a combination of a **Lo-Speed Stack** and a **Hi-Speed Stack with NO Crossover**. Put the valving on the shaft in the order listed, starting with the smallest diameter shim of the Hi-Speed Stack. Then the Lo-Speed Stack gets placed on top of the Hi-Speed Stack. **You will not**

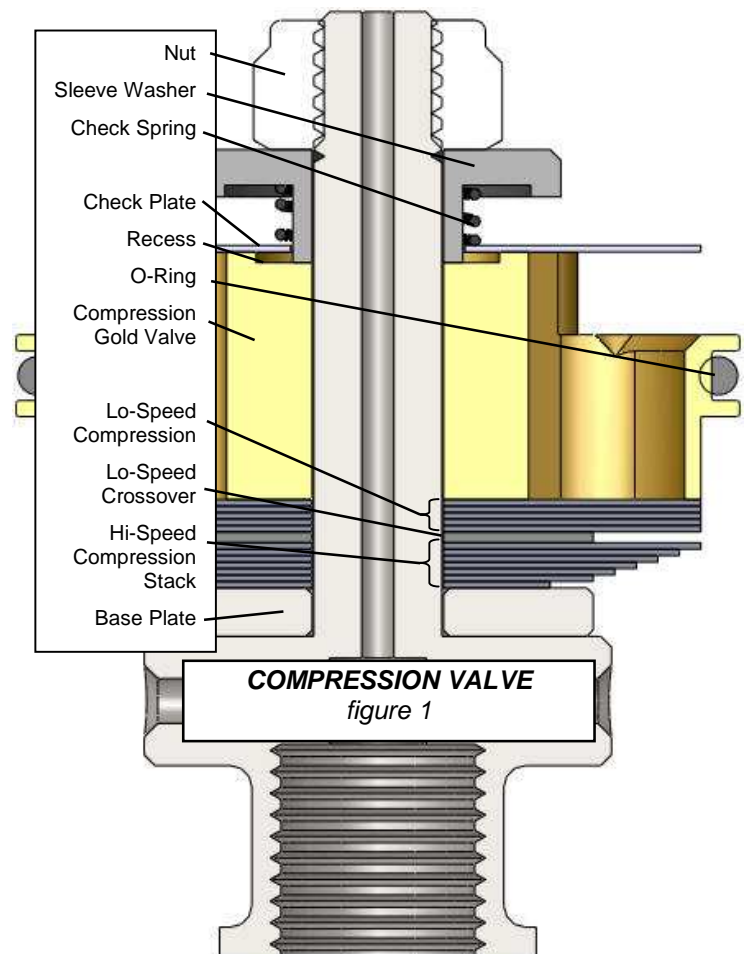

use a Crossover.

- V2b **Two Stage Stacks (shown in figure 1)** - For Two Stage Stacks the total valving stack is made up of a **combination of a Lo-Speed Stack, a Lo-Speed Crossover and a Hi-Speed Stack**. Put the valving on the shaft in the order listed, starting with the smallest diameter shim of the Hi-Speed Stack. Then the Lo-Speed Crossover gets placed on top of the Hi-Speed Stack, then the Lo-Speed Stack ends up closest to the Gold Valve.
- V3 **Place the Gold Valve on the shaft** with the recess on the piston facing up. Make sure the o-ring is on the Gold Valve.
- V4 **Place the Check Plate (large ID washer) and the spring on the shaft**. Next install the Sleeve Washer. Be sure the Check Plate is free to move on the Sleeve Washer before you tighten the nut.
- V5 **Check to see the total valve stack thickness is correct**. You must be very sure that the nut does not run out of thread onto the straight part of the shaft. If it does, the nut will not tighten down on the valving. This will cause incorrect operation or the nut will come off. **This is a critical part of the installation**. To get the proper total valve stack thickness you may need to place some of the original shims on the shaft just on top of the base plate. NOTE: Any shims added must be larger in diameter than the last shim in the stack. **Be sure the nut is fully engaging the thread!**
- V6 **Make sure the check plate is free** and can move up and down against the spring.
- V7 **CAUTION! The thread can be damaged without extreme care. To install the nut you must use Loctite (provided). If you have a 6mm nut (10mm wrench), it must be torqued with a torque wrench to 30 in-lbs (2.5 ft-lbs or 0.35 kgf-m). 8mm nuts must be torqued to 48 in-lbs (4 ft-lbs or 0.56 kgf-m). See the DVS. Do not take this step lightly.**
- V8 **Inspect your work**. For two stage stacks, hold the compression stack up to the light and look for the gap at the crossover between the lo-speed and hi-speed stack. This gap should be visible, if it isn't, disassemble the stack and look for burrs to surface and/or dirt in the valving. Reassemble and check again.

MID-VALVE AND REBOUND

Rebound Gold Valve Kits are highly recommended. You can expect significant improvement in plushness, anti-dive, and traction with these kits. This is a great time to install them.

ASSEMBLY

- A1 **Install the damping rod into the cartridge**. Reassemble the forks according to the procedure in your manual. For Twin-Chamber Forks the damping rod shaft seal must be protected. Pack the thread with heavy grease before inserting it into the cartridge.
- A2 **Fill and bleed the cartridge**. Before installing the compression assembly which includes the reservoir piston and cap, make sure the oil level is 130mm (5.1") down from the top of the cartridge with the damping rod fully extended. When you install the compression assembly it should require quite a bit of force when you push it in with your hand. Once you have tightened the cap compress the damping rod all the way. This will push out any extra oil from inside the cartridge and should be poured out of the holes in the top of the reservoir. When the damping rod is released it should extend all the way by itself. This indicates that there is enough oil inside the cartridge. Torque the cap to manufacturers specs. Consult service manual for specs.
- A3 Use Loctite (provided) on the damping rod thread at the Rebound Adjuster Bolt and **torque it to manufacturers specs** (typically 16 to 21 ft-lbs [21.7 – 28.5 NM]).
- A4 **Adjust the compression and rebound adjusters, spring preload, and oil level** according to the DVS Setup Sheet.
- A5 **Install the forks on the bike**. When the forks are put on the bike it is very important to align the fork tubes. This is done by first tightening the axle all the way, then the tubes are aligned by pumping the forks up and down with the right-hand axle clamp loose. This will line the tubes up so they won't bind. Finally, tighten the axle clamp.

TUNING NOTES

- **Damping depends on vertical wheel velocity, not position in the stroke.**
- **If the forks feel too soft all the way through,** increase compression damping with the external adjuster. If that is not enough, change the compression stack internally.
- **The compression damping adjuster** controls the lowest speed damping and affects the entire range. NOTE: The closer to maximum damping (full clockwise) the more effect one click makes. In other words going from 3 to 2 out has a lot more effect than going from 14 to 13. Adjusters are numbered from all the way clockwise (the slowest or firmest setting).
- **If your valving needs to be stiffer, move to the right on the valving chart.** If the forks are too firm, go the opposite direction, to the left.
- **Spring rate affects ride height, dive and bottoming.** Typical spring preload should be 3-5mm (0.1-0.2").
- **Oil level can drastically alter bottoming resistance and only affects the last part of the travel** (near bottoming). If you like the action but the forks bottom too easily, raise your oil level by 10cc.

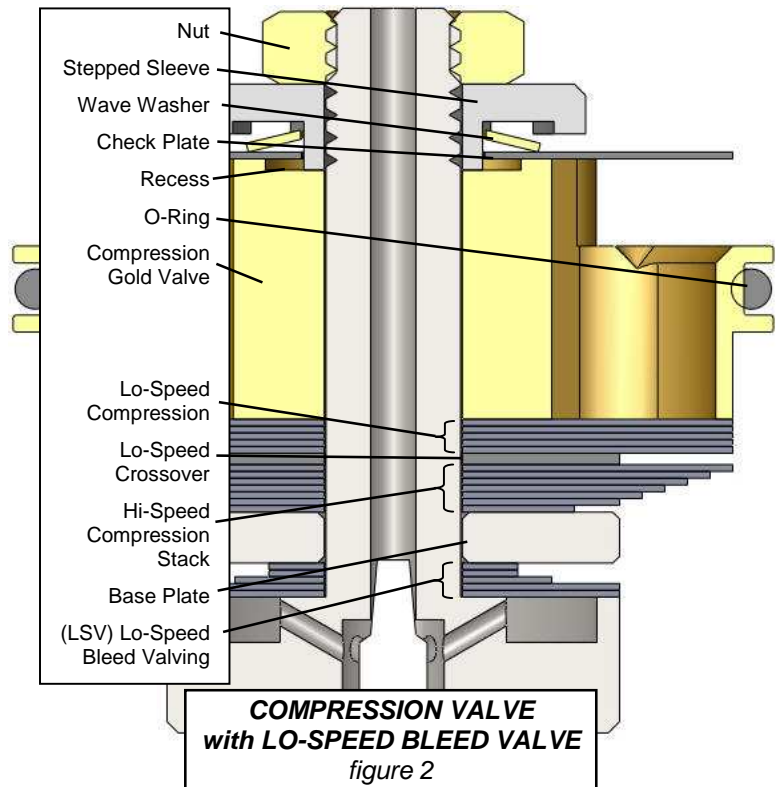
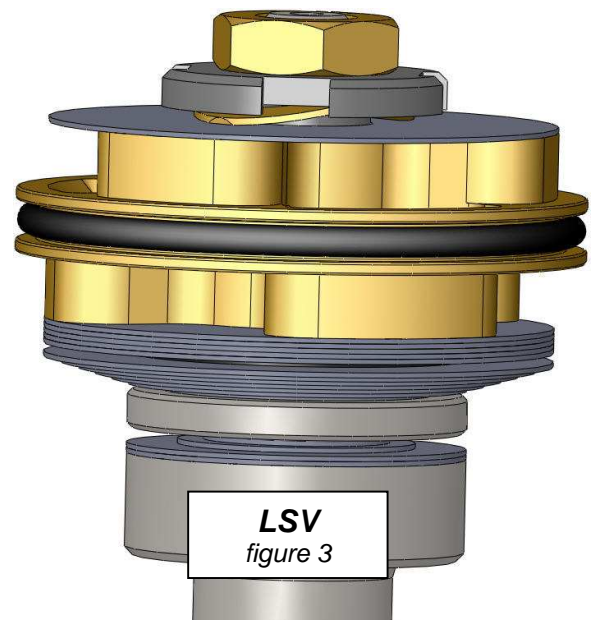
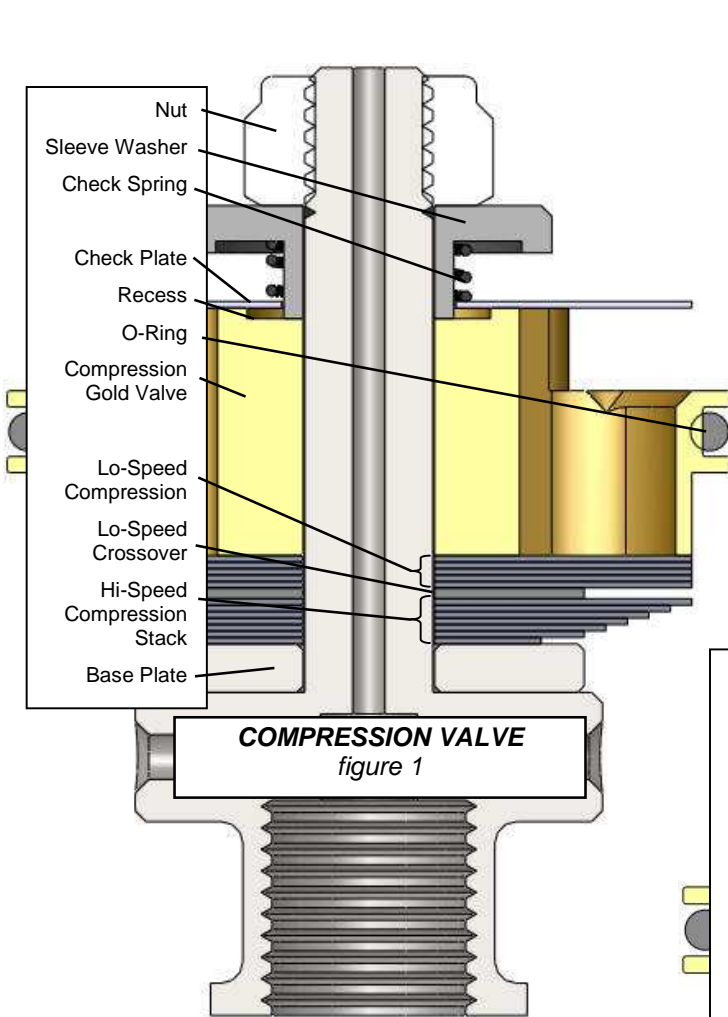

RACE TECH

FK code

FORK REBOUND GOLD VALVE INSTALLATION - DIRT 23 & 24mm

TOOLS REQUIRED: In addition to the tools required for disassembly and assembly. TFHP 01 Holding Tool, TFSH 10 Shaft Holding Tool, Hi-strength Loctite (included), 400 grit (very fine) or finer Sandpaper.

CAUTION: THIS PROCEDURE SHOULD ONLY BE DONE BY A QUALIFIED SUSPENSION TECHNICIAN. IF YOU ARE NOT FAMILIAR WITH THIS PROCEDURE, STOP! CONTACT RACE TECH OR A QUALIFIED SUSPENSION TECHNICIAN.

DISASSEMBLY

- 1 **Disassemble the forks** and remove the cartridge.
- 2 **Remove the compression valve.** If you are installing compression Gold Valves at this time, follow the instructions for installation included in the kit.
- 3 **Remove the rebound rod from the cartridge.** On 07 and earlier Twin Chamber Showa Cartridges both the damping rod and the thread are 12mm. When the damping rod is removed from the cartridge extreme care must be taken so the thread (which is often razor sharp) does not cut the shaft seal. Carefully deburr both ends of the thread and pack the thread with grease.
- 4 **Once the rod is removed lightly file the peening off the end of the shaft that holds on the nut.** Remove the nut and **disassemble the valving stack.** Lightly deburr the end of the thread.

VALVING

- 5 Select the Rebound and Mid-Valve Valving. Begin **assembling the Rebound Gold Valve.** Starting with the Special Cupped Washer, Check Spring, MV Packing Stack and Mid-Valve Stack. There are two critical components of the Mid-Valve; the stiffness of the Mid-Valve Stack and the "Float". The Float is controlled by a combination of the thicknesses of the MV Stack and the MV Packing Stack.
- 6 **Install the Rebound Gold Valve** with the recess toward the Mid-Valve Stack.
- 7 **Select the Rebound Valving Stack.** Continue assembly. Install the Lo-Speed Rebound Valving Stack, Lo-Speed Crossover, Hi-Speed Rebound Valving Stack, Base Plate and Nut. Make sure the total stack height is correct and the Base Plate straddles the end of the thread. Use Loctite and torque the nut to 30 in-lbs (0.35 kgf-m).

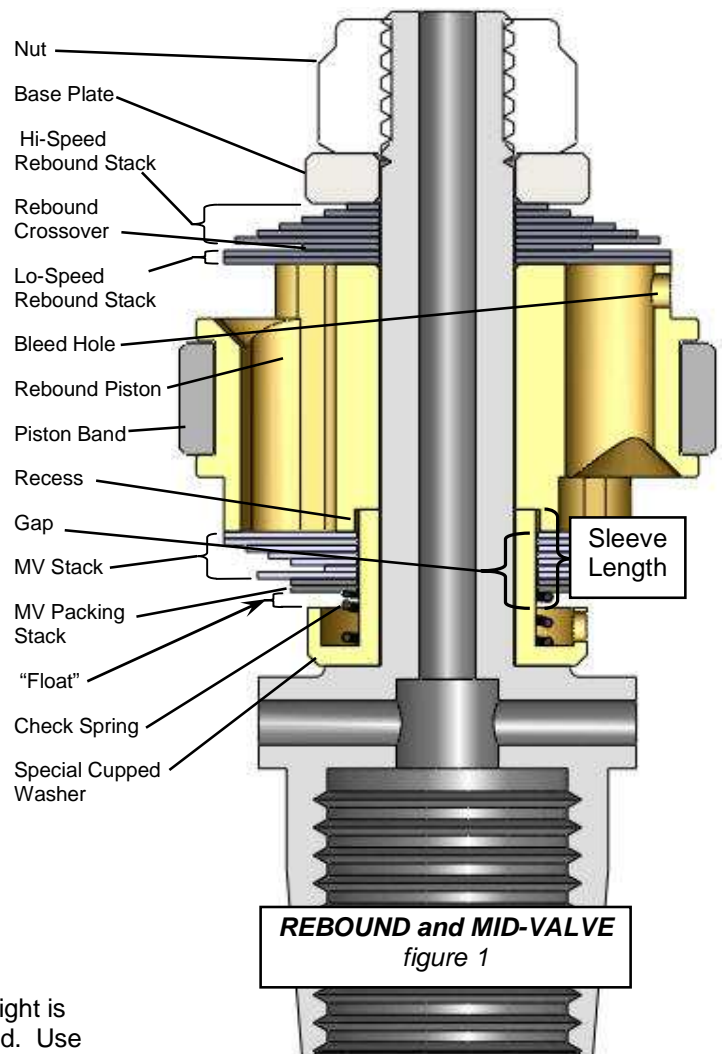

ASSEMBLY

- 8 **Reinstall the rod** into the cartridge being careful not to damage the shaft seal. Make sure there are no burrs on the thread and pack the thread with heavy grease before you insert it into the cartridge. Screw the Jam Nut onto the end of the Shaft all the way.
- 9 **Fill and bleed the cartridge. Set the oil level inside the cartridge to the recommended level (note – this level is more than the cartridge requires, excess will be drained off.)** Install the compression assembly and compress the damping rod completely. Pour out excess oil above the reservoir piston.
- 10 **Reassemble the forks.** Install the Fork Spring. Install the Cartridge and temporarily screw in the fork cap. Invert the fork and place the cap on the floor on a soft surface so the cap will not be damaged. Compress the fork so the Damping Rod extends through the bottom of the fork and slide the TFHP 01 Holding Tool between the Jam Nut and the Fork Bottom.
- 11 Use Loctite on the damping rod thread at the Rebound Adjuster. **Insert the Rebound Adjusting Rod into the Damping Rod** making sure it goes in all the way and registers on the Needle inside. There are two types; Showa – “D” Shaped Rod and KYB/WP Round Rod.
The Showa “D” Shaped Rod requires special attention. Slide the “D” Shaped drive rod on the Adjuster Bolt into the Rod. When you screw on the Adjuster Bolt, hold the Adjusting Screw in one place with a screwdriver. This will keep the “D” Shaped Rod from rounding out.
For the KYB/WP Round Rods back out the adjuster on the Adjuster Bolt before installing it on the Rod.
- 12 **Torque the jam nut to manufacturers specs** (typically 16 to 21 ft-lbs [21.7 – 28.5 NM]). Consult shop manual for specs. Remove the Holding Tool and tighten the Adjuster Bolt into the Fork Bottom.
- 13 Unscrew the Fork Cap and add the proper oil volume to the outer chamber
Tighten the fork cap.
- 14 **Set the compression and rebound adjustments** to the recommendation. This should be a good starting point. Enjoy!

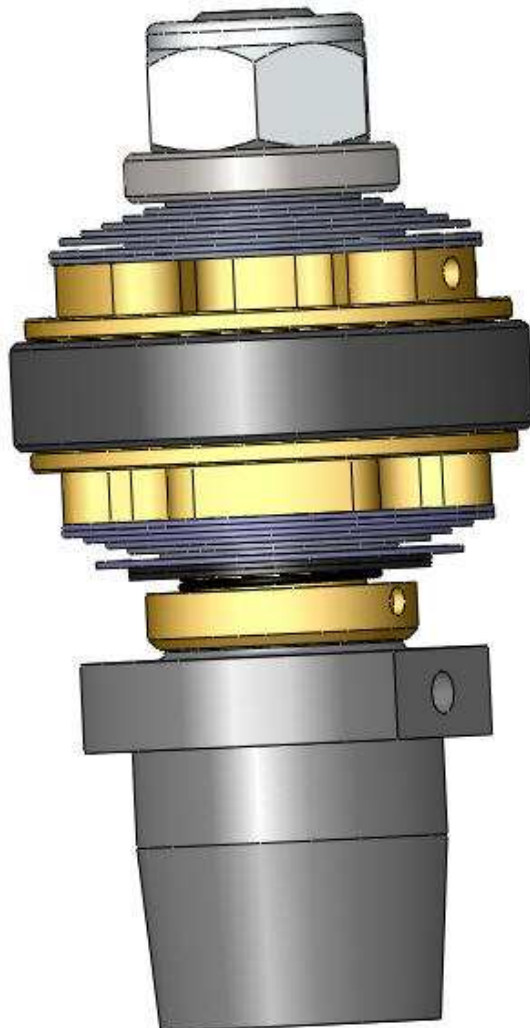

Rebound Valving Selection Chart DIRT 23&24mm FRGV 2301/FRGV 2401

Welcome to the wonderful world of Gold Valving.

To obtain your personal Custom Suspension Settings:

1. Go to Digital Valving Search (DVS)
2. Input your Access Code (on top of page 1) when prompted
3. Input your personal specifications
4. Print your DVS Custom Suspension Setup Sheet

EXAMPLE:

The **Total Mid-Valve Stack** is MV34 and MVP20.

Starting from the **recessed** Gold Valve piston face:

Mid-Valve Stack – MV34 - .90mm thick

- (3) 0.10x20
- (1) 0.10x18
- (1) 0.10x16
- (1) 0.10x14
- (1) 0.10x11
- (1) 0.20x17

Mid-Valve Packing Stack – MVP20 - .20mm thick

- (2) 0.10x14

Float = Gap – Total Stack Thickness

For this example:

Sleeve Length	2.50
Recess (std Gold Valve)	— 1.00
Gap	= 1.50

MV Stack	.90
MVP Packing	+ .20
Total Stack Thickness	= 1.10

Gap	1.50
Total Stack Thickness	— 1.10
Float	= .40

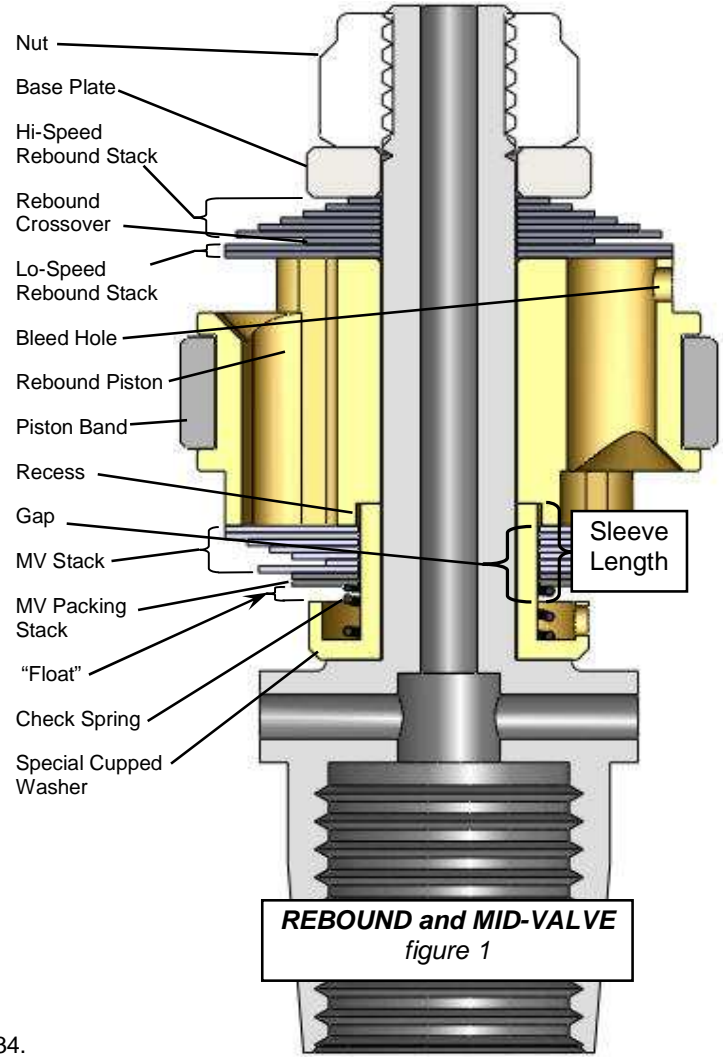

Next build the Rebound Valving Stack.

EXAMPLE:

The **Total Rebound Valving Stack** is rL1004, rLX1012, and rH34.

Starting from the **flat** Gold Valve piston face:

Lo-Speed Stack – rL1004

- (4) 0.10x20

Lo-Speed Stack – rLX1012

- (1) 0.10x12

Hi-Speed Stack – rH34

- (1) 0.10x20
- (1) 0.10x18
- (1) 0.10x14
- (1) 0.10x12
- (1) 0.10x11
- (1) 0.10x10