

**SUZUKI DL 650 V-STROM**

**Ref: 9719**

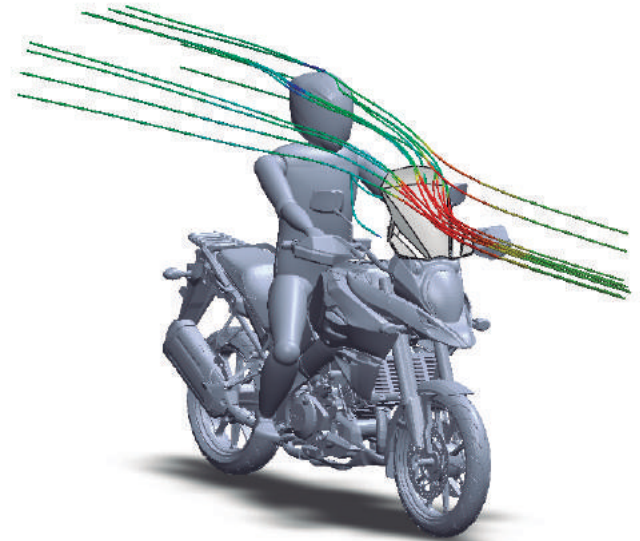
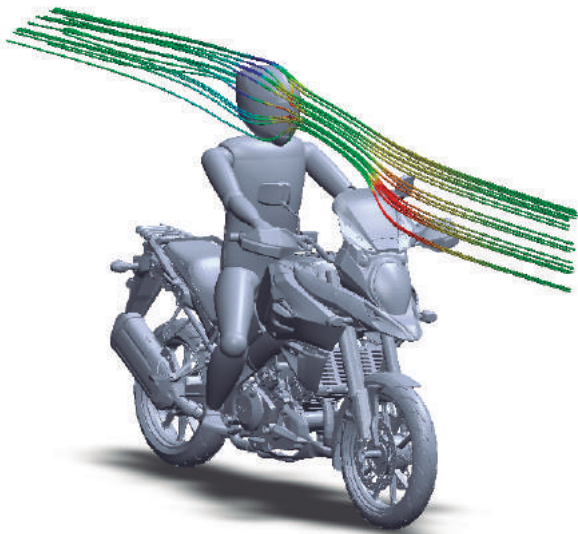

**OEM SCREEN**

**PUIG SCREEN**

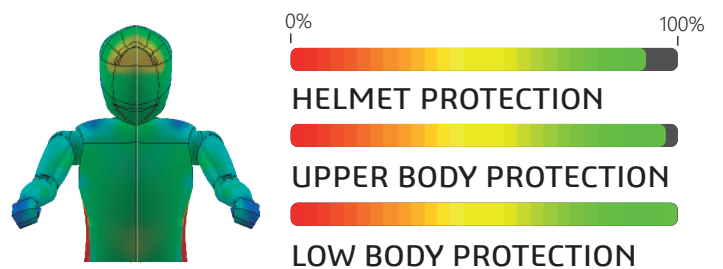
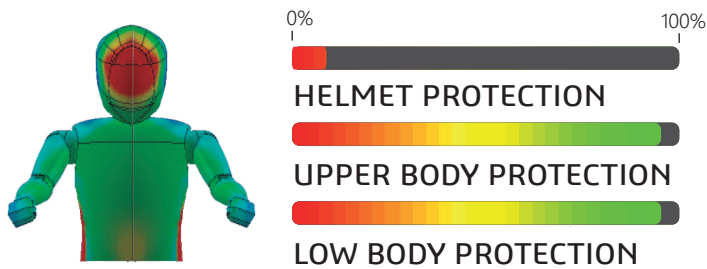

AERODYNAMIC TEST CONDITIONS	
SPEED	150 km/h   94 mph
RIDER HEIGHT	180cm   5.9 ft
TEMPERATURE	20 °C   68 °F
RIDER POSITION	Standard
LATERAL WIND	No

Total dissipated pressure with puig screen is equivalent to 1.73kg

**81%** IMPROVED AERODYNAMIC WIND PROTECTION WITH PUIG SCREEN *Without losing Cx*

# SUZUKI V-STROM DL650 17' - Cúpula Touring

**Puig**  
Hi-Tech Parts

Max. protection +120mm [+4,72in]

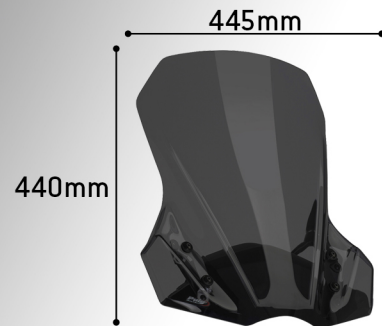

**9719F**

**9719H**

**OEM**

Learn more about motorcycle windshields and fairings we have.