

WINDSHIELD WITH SELF-ADJUSTING INCLINATION SYSTEM

DUCATI X-DIAVEL



Ref.: 8921
(Mod. SPORT)



Ref.: 8922
(Mod. TOURING)

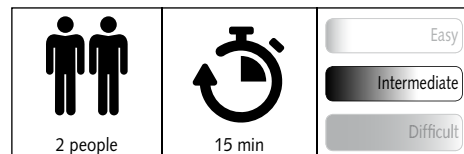
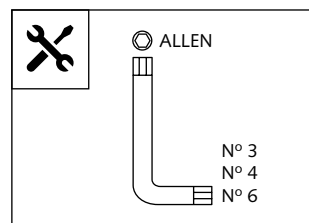

ID.	PART	DESCRIPTION	QTY.
1		SPORT screen (8921)	1
		TOURING screen (8922)	
2		Fixed metal support	1
3		Mobile right metal support	1
4		Mobile left metal support	1
5		Locking handle	1
6		Ø int. 8 x Ø ext. 14 x 22 arrowhead (black)	4
7		M8 x 50 DIN 912 (black) Allen screw	4
8		Ø int. 8,5 x Ø ext. 17 x 1,5 rubber washer	2
9		Ø int. 8,5 x Ø ext. 17 x 1,5 (black) metal washer	2
10		M5 x 16 ISO 7380 (black) Allen screw	4
11		M5 x 0,5 nylon washer	4
12		Silentblock M5	4
13		M6 x 10 ISO 7380 (black) Allen screw	2
14		Ø int. 6 x Ø ext. 8 x 5,5 arrowhead	2
15		M6 x 1 nylon washer	2
16		M6 blind nut	2
17		Sticker (served mounted)	1
18		M8 Allen screw cap	4

WINDSHIELD WITH SELF-ADJUSTING INCLINATION SYSTEM

DUCATI X-DIAVEL

MOUNTING INSTRUCTIONS

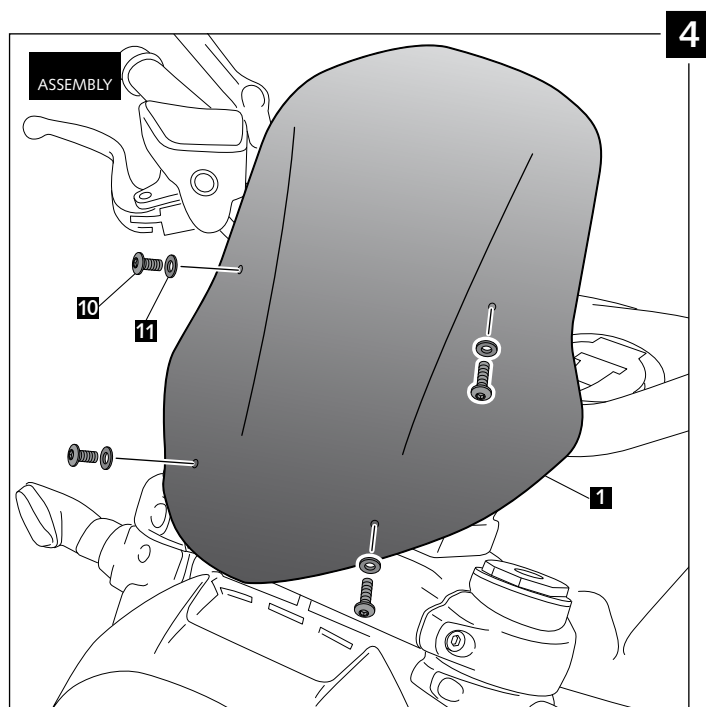
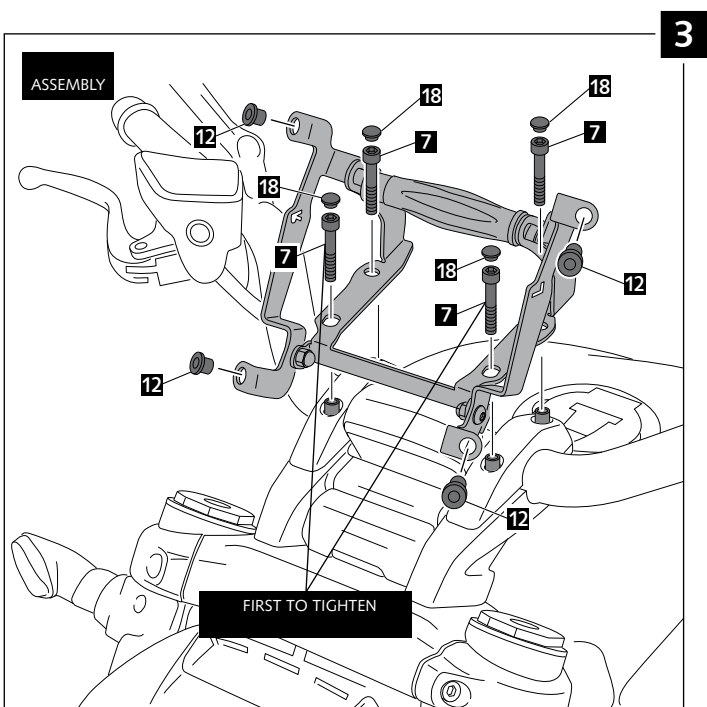
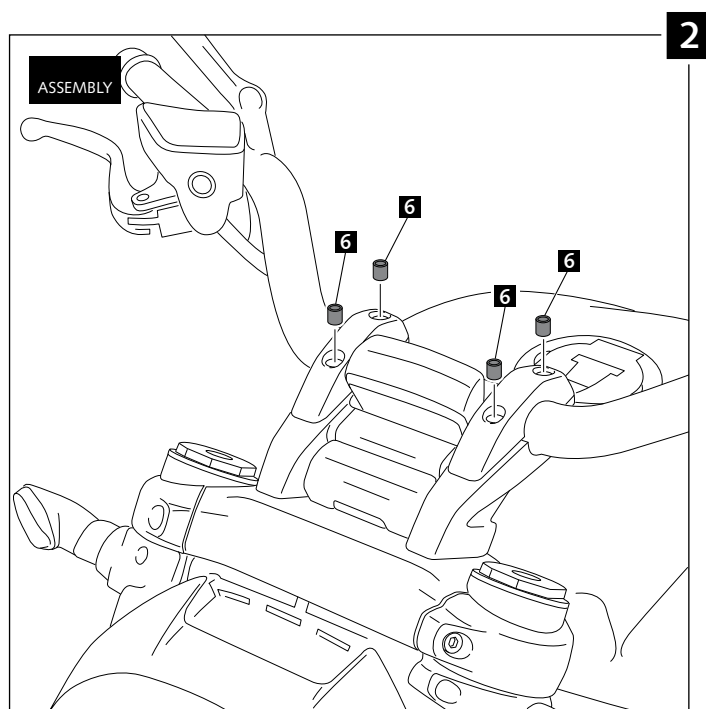
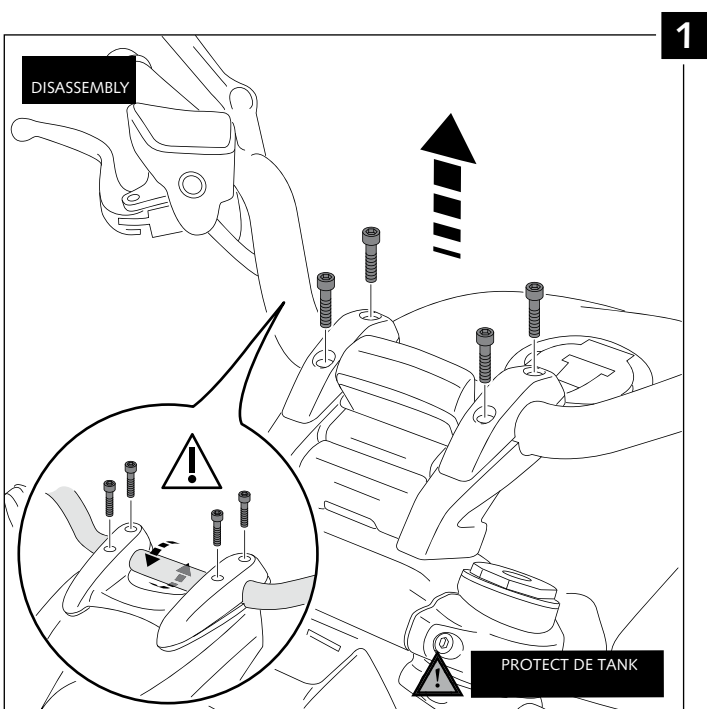

WINDSHIELD WITH SELF-ADJUSTING INCLINATION SYSTEM

DUCATI X-DIAVEL

MOUNTING INSTRUCTIONS

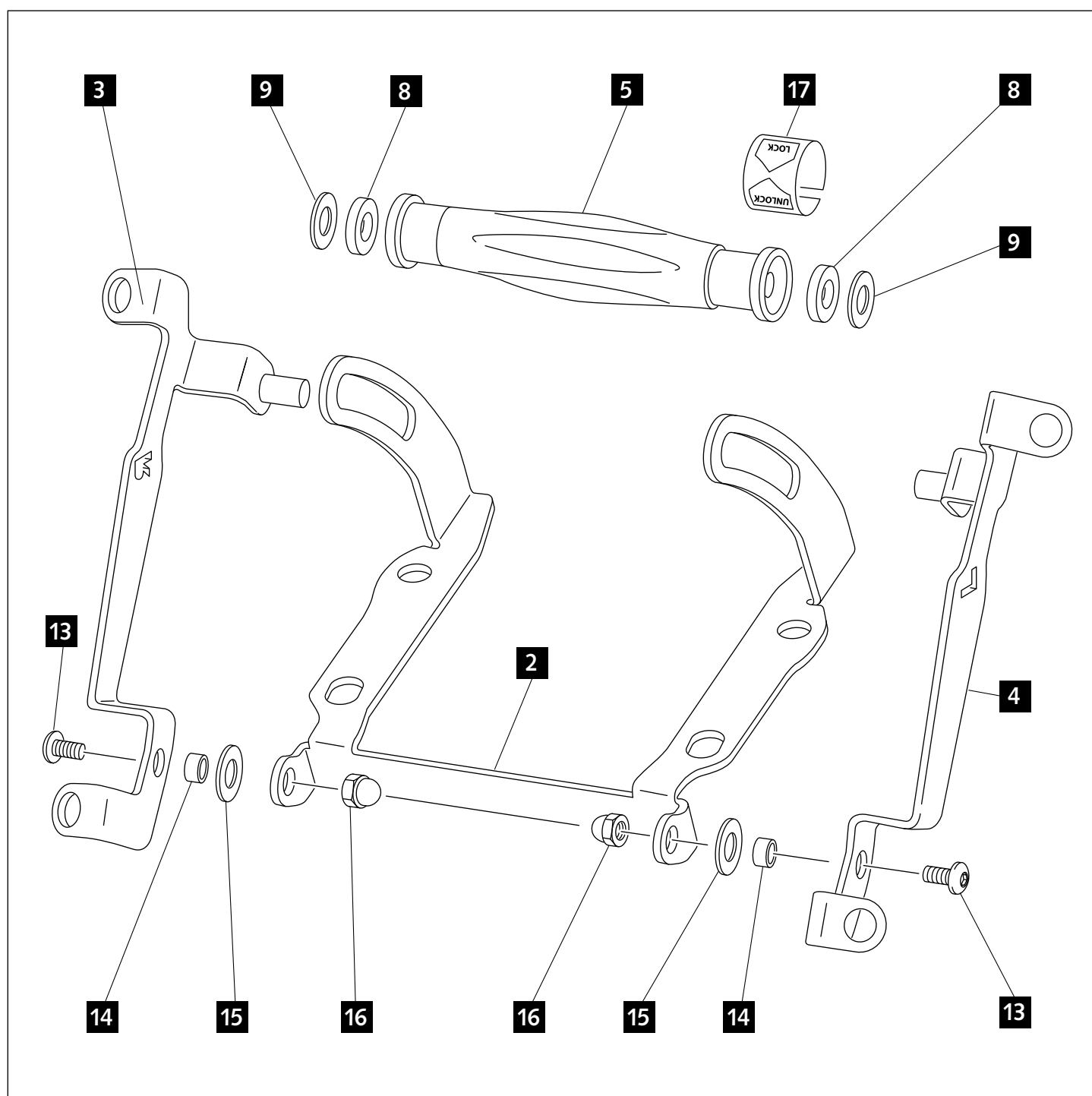

TIPS FOR A CORRECT WINDSCREEN ASSEMBLY

Due to storage and transport processes of the windscreens, which are subjected to positions and temperature changes out of our control, this may produce small deformations on the material causing some difficulties on the mounting process. It is recommended to:

- 1- Place the screws on one side without tighten all the way.
- 2- Stretch the windscreen to the other side (see Fig. 1). The flexibility of the material allows this stretch with no risk of breaking or cracking.
- 3- Place the screws without tightening all the way.
- 4- Tighten progressively all the screws.

