

COMPARISON

AERODYNAMIC TEST

BMW F800R

2015 -

WITHOUT SCREEN

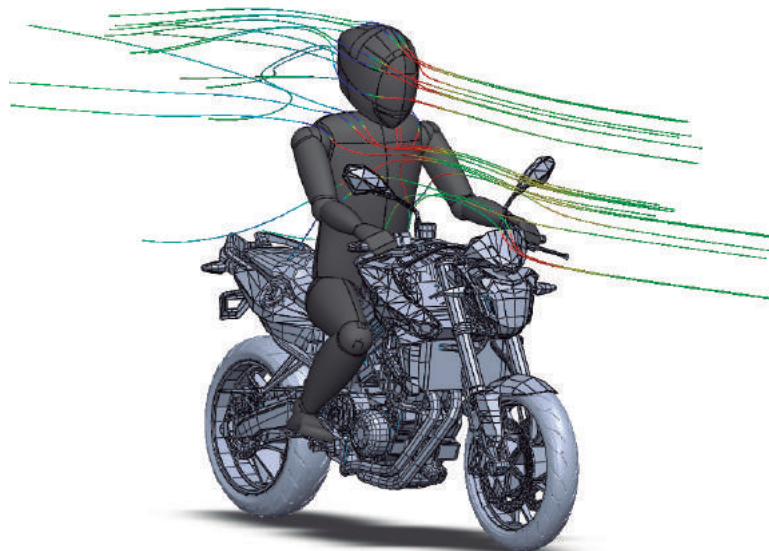

HELMET PROTECTION

0%

UPPER BODY PROTECTION

0%

LOW BODY PROTECTION

50%

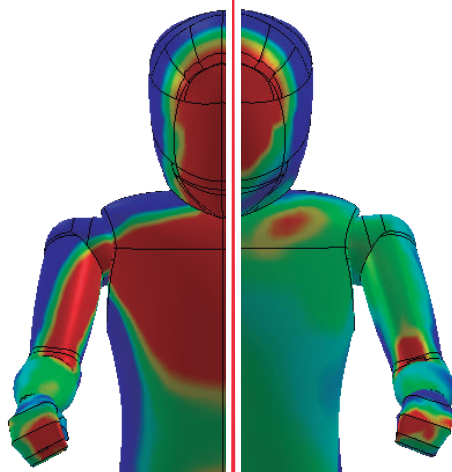

Puig
Hi-Tech Parts

TOURING SCREEN

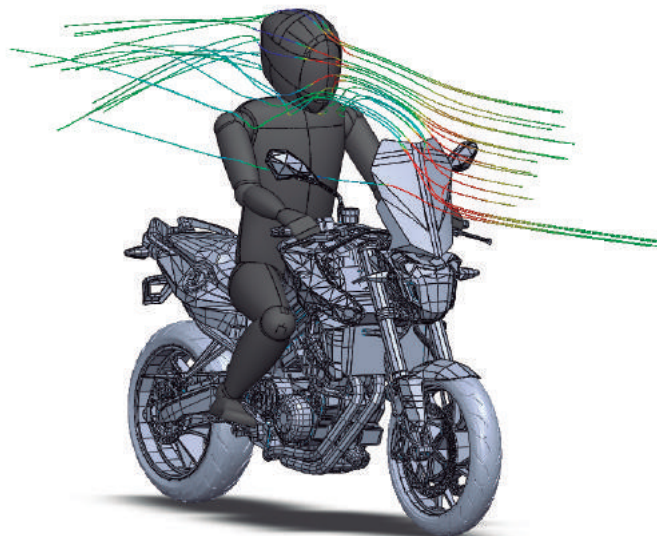

HELMET PROTECTION

40%

UPPER BODY PROTECTION

61%

LOW BODY PROTECTION

100%

LOW PRESSURE

HIGH PRESSURE

TOTAL DISSIPATED PRESSURE WITH PUIG SCREEN IS EQUIVALENT TO **6.18 Kg**

INCREASE WIND PROTECTION

55% WITHOUT LOSING Cx

AERODYNAMIC TEST CONDITIONS

SPEED	150 Km/h	94 mph
RIDER HEIGH	180 cm	5.9 ft
TEMPERATURE	20°	68°F
RIDER POSITION		Standard
LATERAL WIND		No

BMW F800R '15-

Since 1964
Puig
Hi-Tech Parts

Naked New Generation (Touring)



◀◀ Max. protection +265mm (10^{1/2}") ▶▶

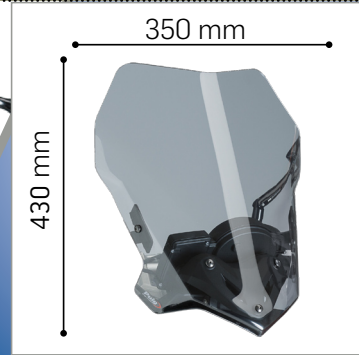

8187H

8187W

OEM

Learn more about motorcycle windshields and fairings we have.