

Windshield New Generation

BMW R1200R

Ref. : 8110/8165



ORIGINAL SCREEN RESULTS

HELMET MAXIMUM PRESSURE	11.38 gf/cm ²
BODY MAXIMUM PRESSURE	32.42 gf/cm ²



PUIG SCREEN RESULTS

HELMET MAXIMUM PRESSURE	6.77 gf/cm ²
BODY MAXIMUM PRESSURE	0.15 gf/cm ²

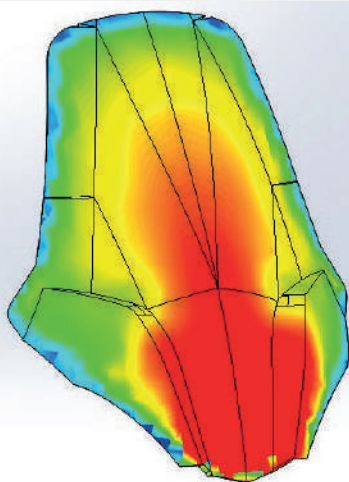

TEST CONDITIONS

SPEED	150 km/h	93 mph
RIDER HEIGHT	180 cm	5.9 ft
RIDER POSITION	Standard	
LATERAL WIND	No	
TEMPERATURE	20°C	68°F

The total dissipated pressure with puig screen is equivalent to 7.78 Kgf.

97%

IMPROVED AERODYNAMIC WIND PROTECTION WITH PUIG SCREEN

Without losing Cx

BMW R1200R '15-

Since 1964
Puig
Hi-Tech Parts

Naked New Generation TOURING

◀◀ Max. protection +250mm (9^{3/4"}) ▶▶

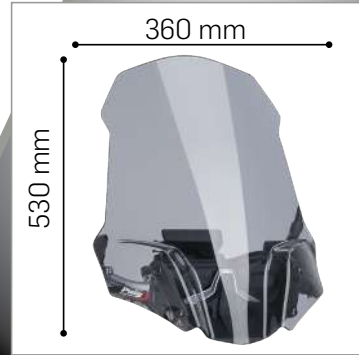

8165W

8165H

OEM

Learn more about motorcycle windshields and fairings we have.