

MOUNTING INSTRUCTIONS

CRASH PADS FOR HONDA CB125F 15'

Ref.: 7931

INSTRUCTIONS TO ASSEMBLE

Remove the fasteners that subject the chassis to the engine, on the point marked below (and the opposite side). Mount the protectors on each own side as the figure below shows. Tight the set, and place the caps.
 All the screws replaced, should be tightened to the torque specified in the oem maintenance manual for your motorcycle. if no torque specifications are provided in the oem maintenance manual, may be used 54Nm for all M10 screws.
 Medium strength liquid thread-locker (i.e., "Loctite") should be used to secure all screws, bolts and nuts.
 All screws, bolts and nuts should be checked after driving the first 50 km to ensure that all are tightened to the proper torque.

| ID. | DESCRIPTION | QTY. |
|-----|-------------------------|------|
| 1 | Plastic lids | 2 |
| 2 | M10/150X20 DIN912 screw | 2 |
| 3 | M10/150x125 thread rod | 1 |
| 4 | M10 DIN125/A washer | 2 |
| 5 | Nylon protector | 2 |
| 6 | Aluminium arrowhead | 2 |

FOR TO ASSEMBLE THE CRASH PADS, IF YOU ARE NOT A TRAINED MECHANIC, PLEASE CONTACT A SPECIALIST. MOTOPLASTIC, S.A. TAKES NO RESPONSIBILITY FOR DAMAGES CAUSED BY IMPROPER INSTALLATION. THE USE OF CRASH PADS DO NOT GUARANTEE A FULL PROTECTION IN CASE OF ACCIDENT. MOTOPLASTIC-PUIG DECLINE ANY RESPONSIBILITY IN CASE OF MOTORCYCLE DAMAGE. IF YOU ARE USING THE MOTORCYCLE IN THE CIRCUIT, MAKE SURE THAT THE MOTOR PROTECTOR DON'T TOUCH THE GROUND BEFORE THE MAXIMUM ELEVATION THAT YOU WANT TO ACHIEVE.

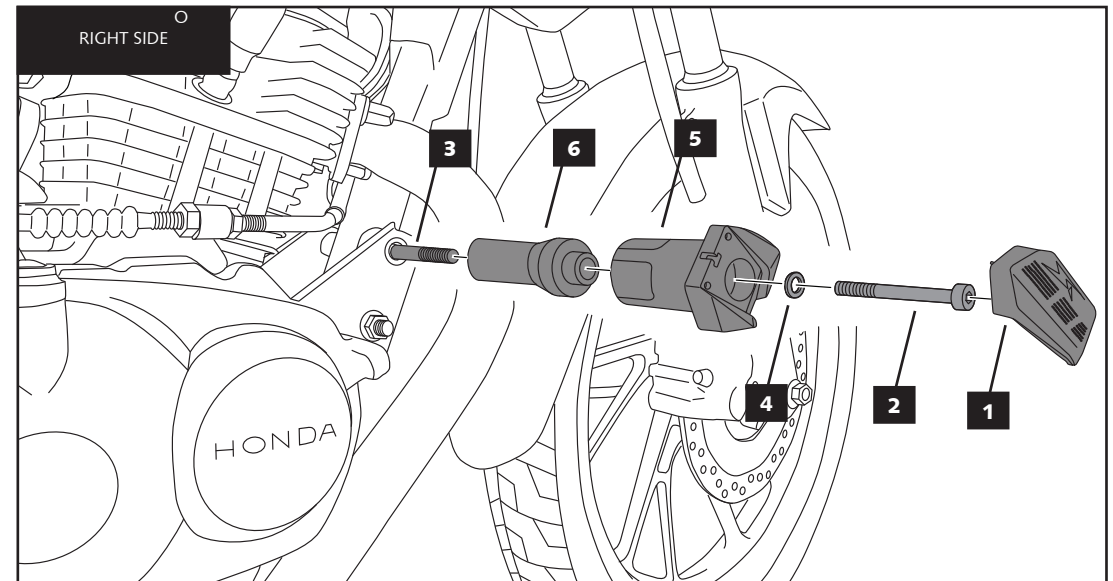
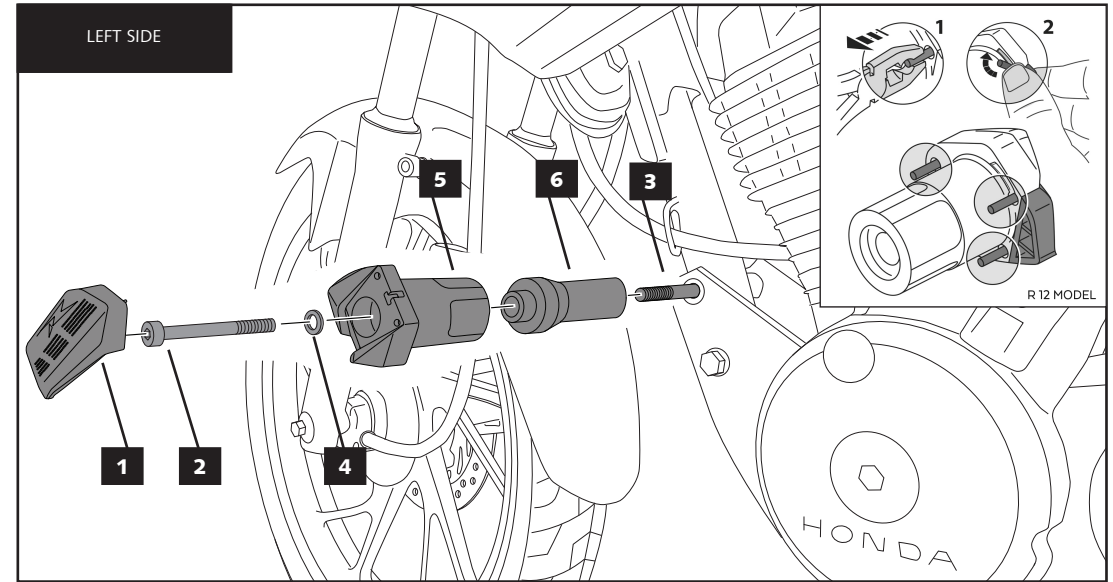

Learn more about motorcycle guards and protection we have.