

INSTRUCTIONS TO ASSEMBLE

Remove the fasteners that subject the chassis to the engine, on the point marked below (and the opposite side). Mount the protectors on each own side as the figure below shows. Tight the set, and place the caps.

All the screws replaced, should be tightened to the torque specified in the oem maintenance manual for your motorcycle. if no torque specifications are provided in the oem maintenance manual, may be used 54Nm for all M10 screws.

Medium strength liquid thread-locker (i.e., "Loctite") should be used to secure all screws, bolts and nuts.

All screws, bolts and nuts should be checked after driving the first 50 km to ensure that all are tightened to the proper torque.

ID.	DESCRIPTION	QTY.
1	Left engine protector	1
2	Right engine protector	1
3	Upper support protector	1
4	M8x30 DIN933 screw	2
5	M8 DIN125/A washer	9
6	M8 DIN985 locknut	2
7	M8x30 DIN912 allen screw	2
8	M8x25 DIN912 allen screw	3
9	M8 DIN6923 washer nut	2
10	Plastic cap	4

MOUNTING INSTRUCTIONS

ENGINE GUARDS FOR KAWASAKI VERSYS 650 15'

Ref.: 7773N

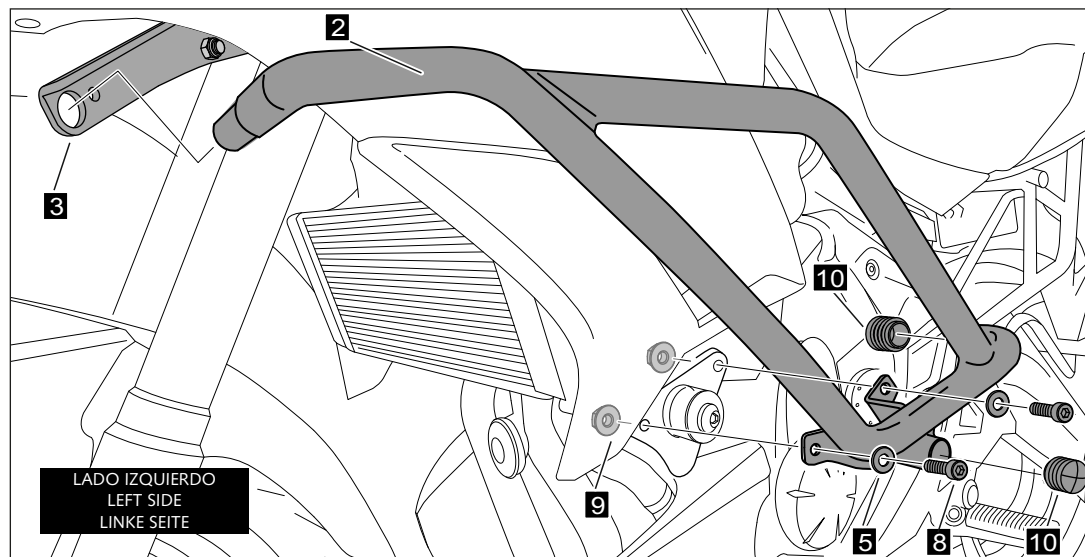
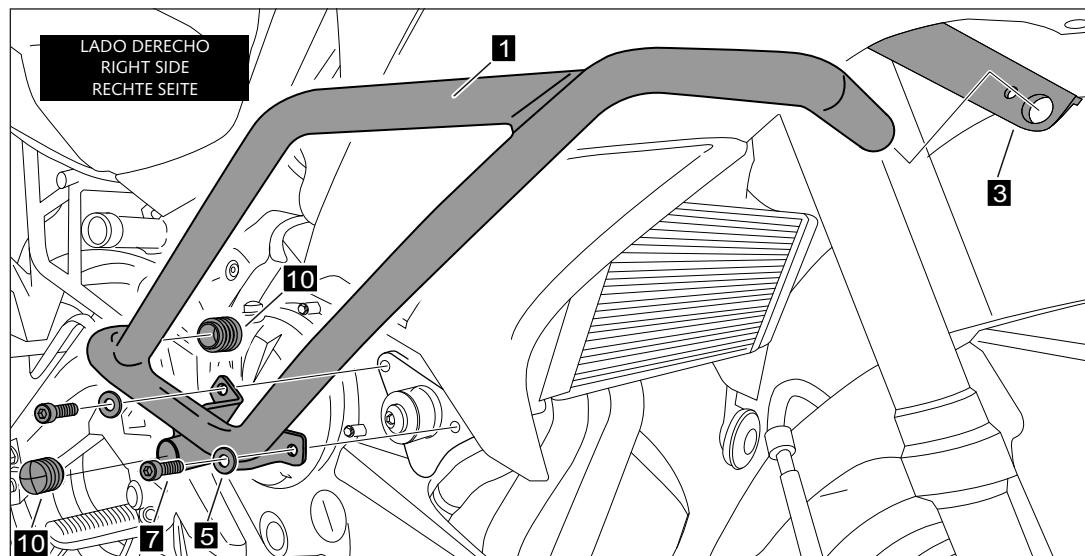

ENGINE GUARDS FOR
KAWASAKI VERSYS 650 15'

Ref.: 7773N

