

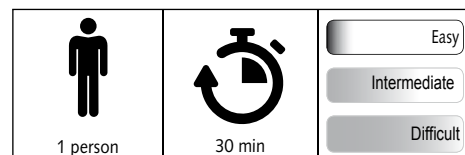

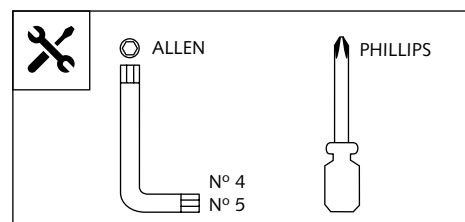

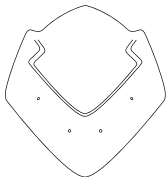

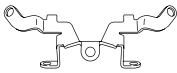

## WINDSHIELD FOR SUZUKI GSX-S1000

Ref.: 7653



ID	PART	DESCRIPTION	QTY	REF.
1		Windshield	1	7653A/C/F/H/N/R/WM3
2		Black cover	1	7653A/C/F/H/N/R/WM3
3		Central metal support	1	SOPOR-3P-3-7653
4		Right special riveted washer	1	SOPOR-3P-3-7653
5		Left special riveted washer	1	SOPOR-3P-3-7653
6		M5x16 ISO 7380 Allen screw (small head)	2	TORNIAI7380-281
7		M5x16 ISO 7380 Allen screw (big head)	7	TORNI-I7380-493
8		M5 ISO7380 Allen screw cap	7	TAPON-----85
9		M5x0,5 nylon washer	7	ARNV00000000245
10		M5 Silentblock	7	SILENBM5-046/1

## WINDSHIELD FOR SUZUKI GSX-S1000

### MOUNTING INSTRUCTIONS

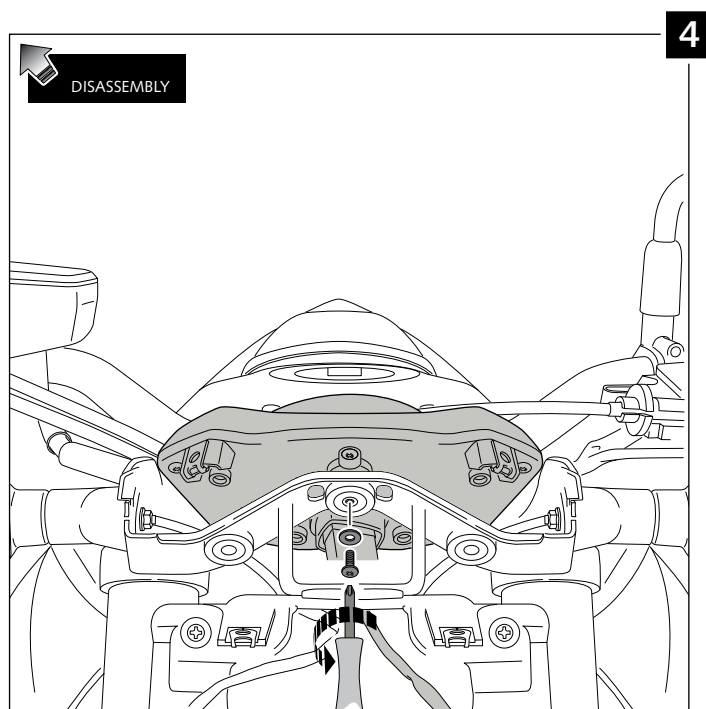
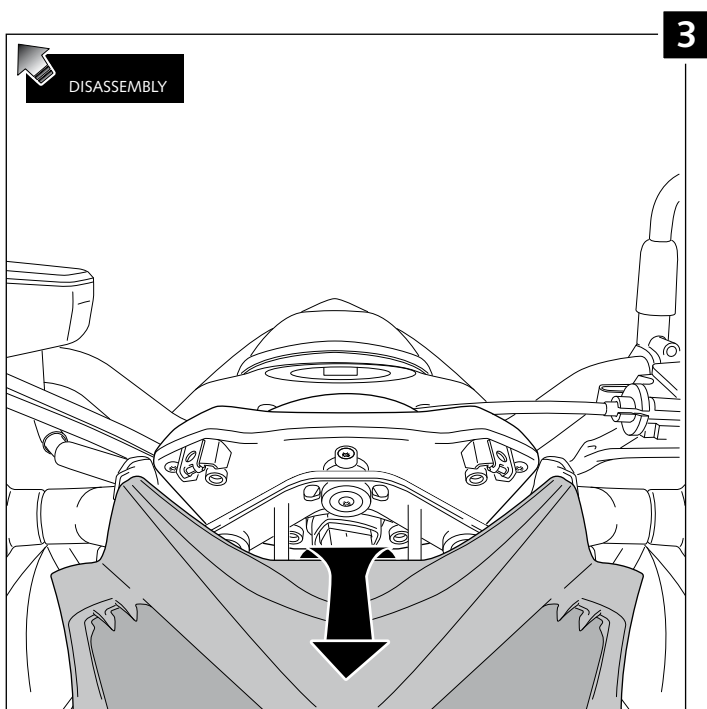
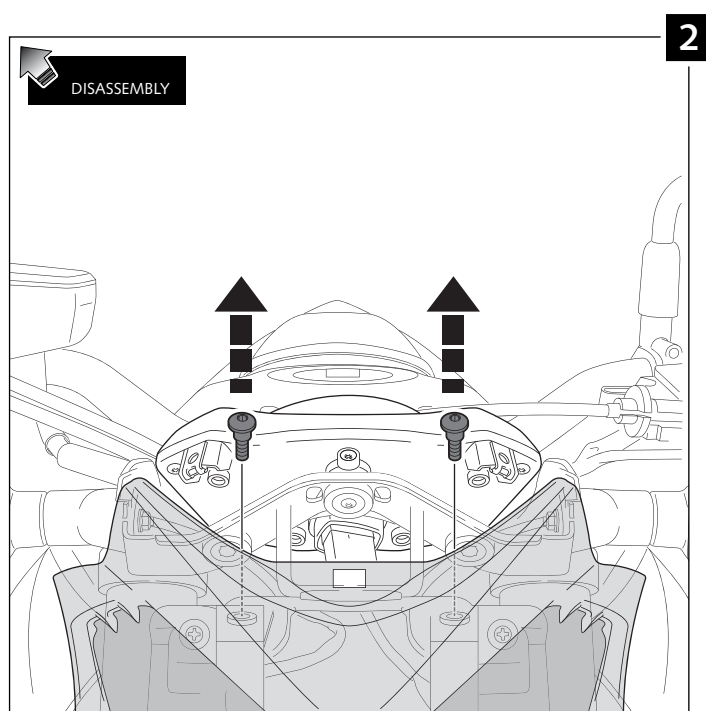
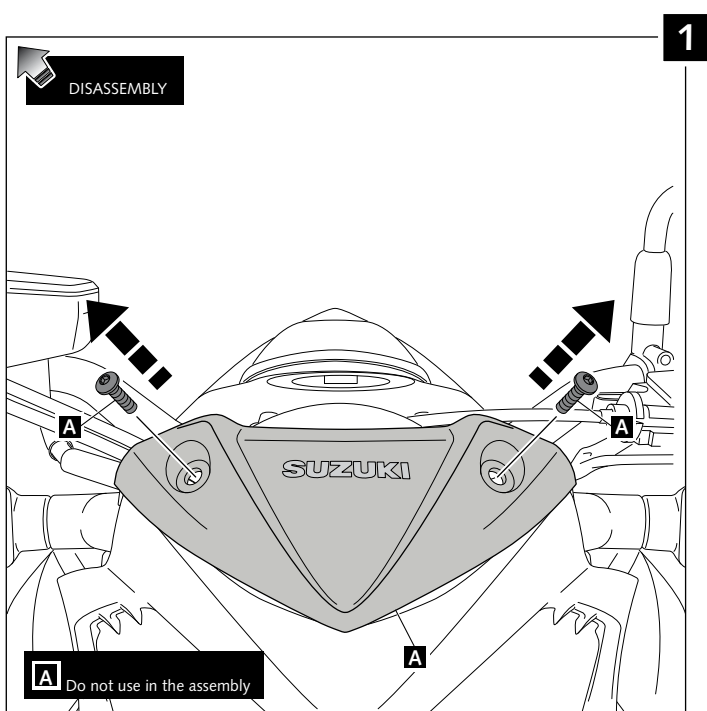

## WINDSHIELD FOR SUZUKI GSX-S1000

### MOUNTING INSTRUCTIONS

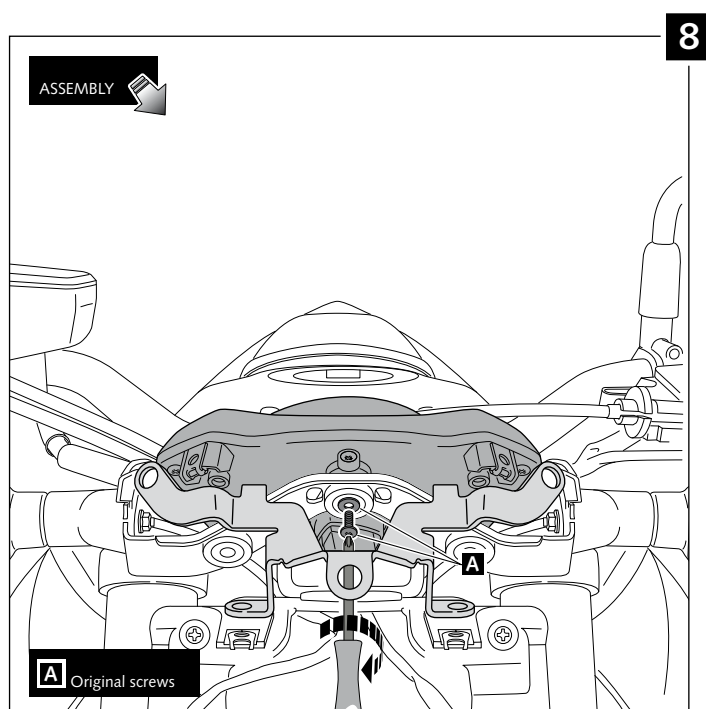
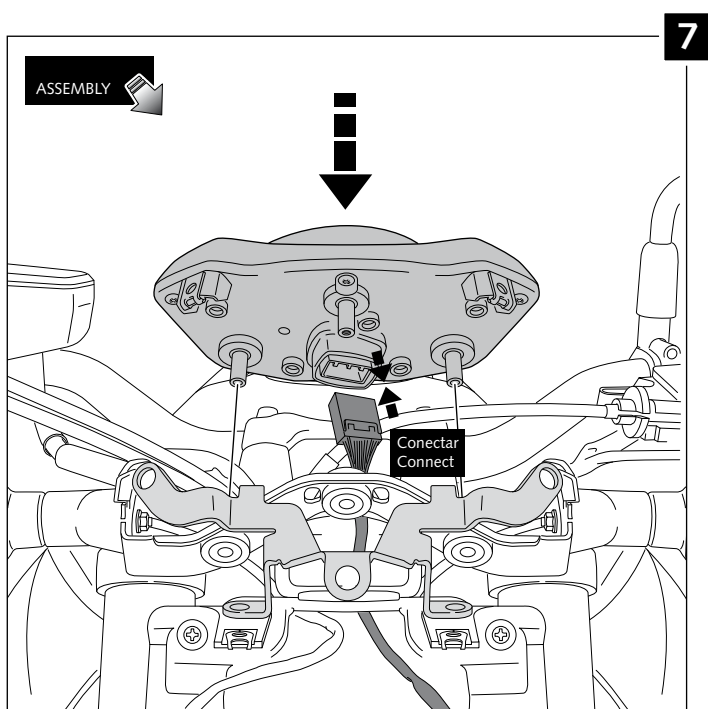
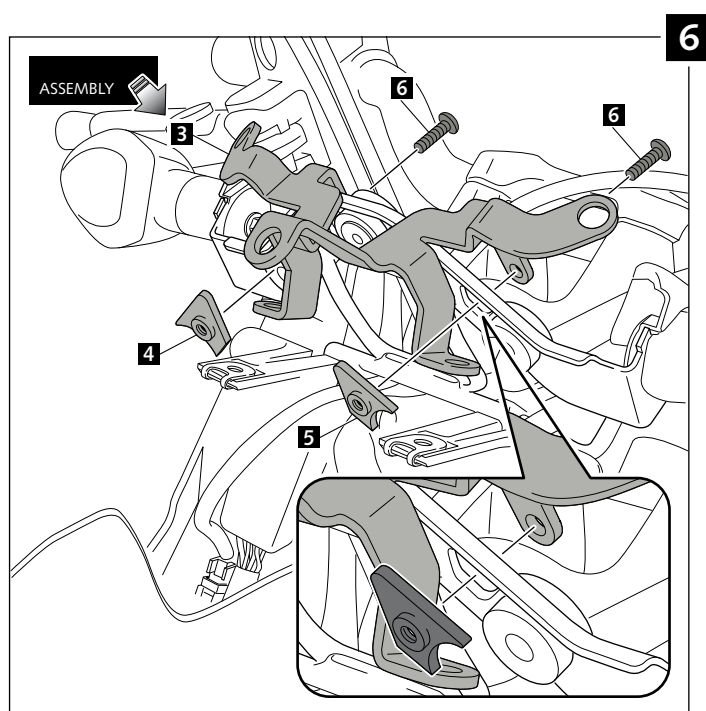
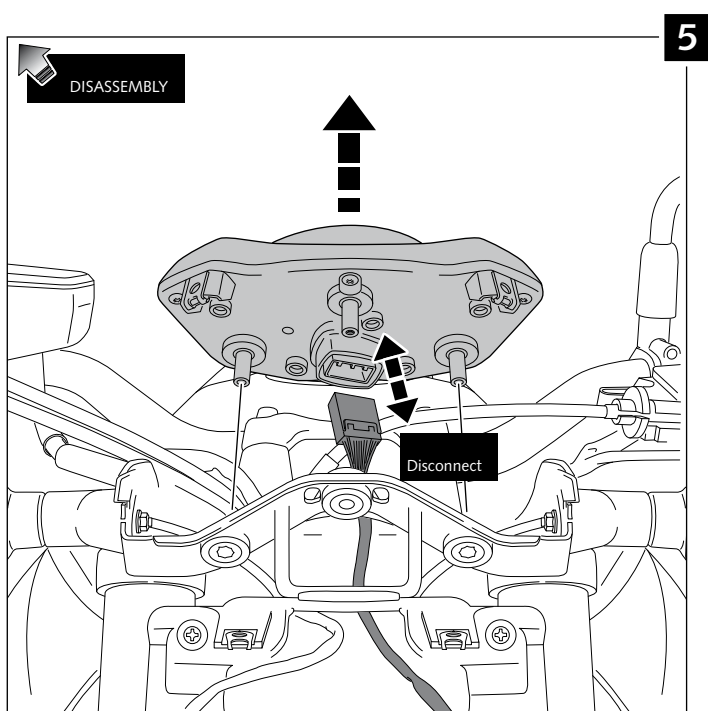

## WINDSHIELD FOR - WINDS SUZUKI GSX-S1000

### MOUNTING INSTRUCTIONS

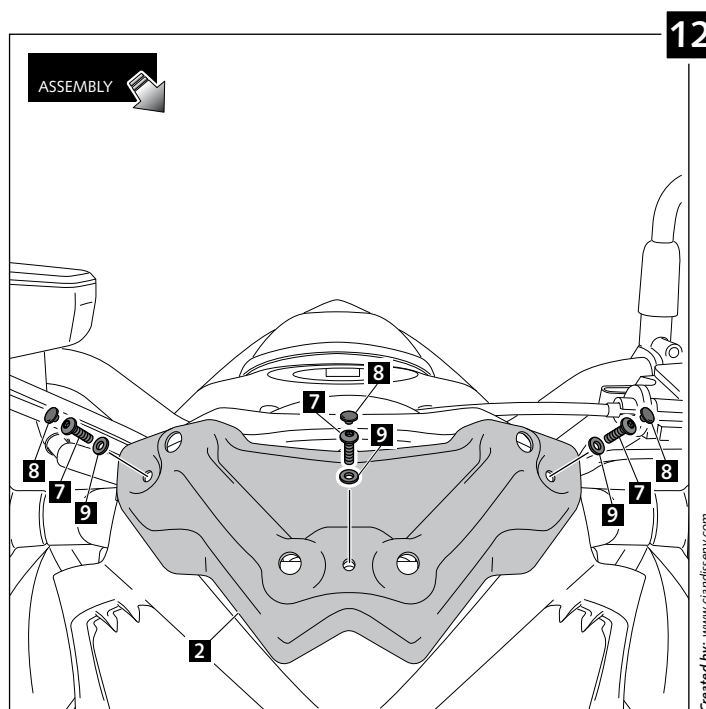
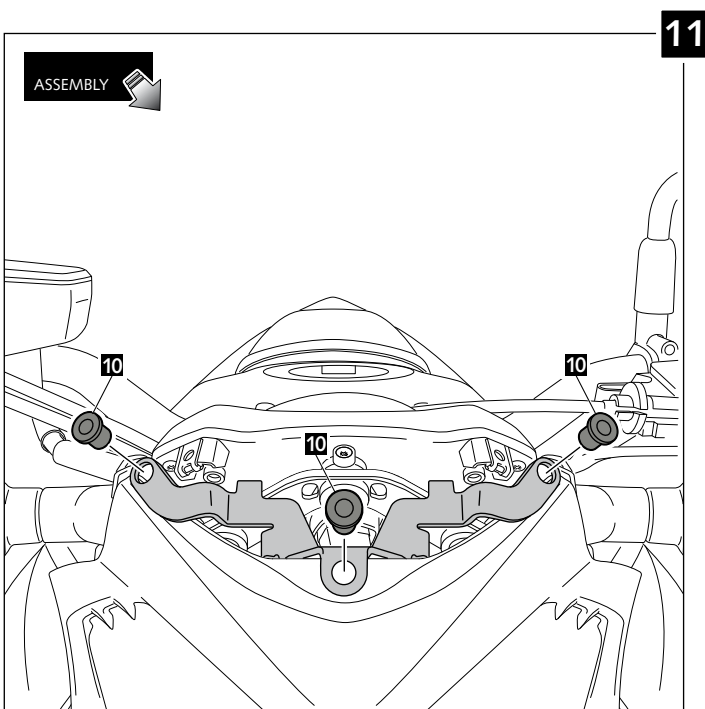
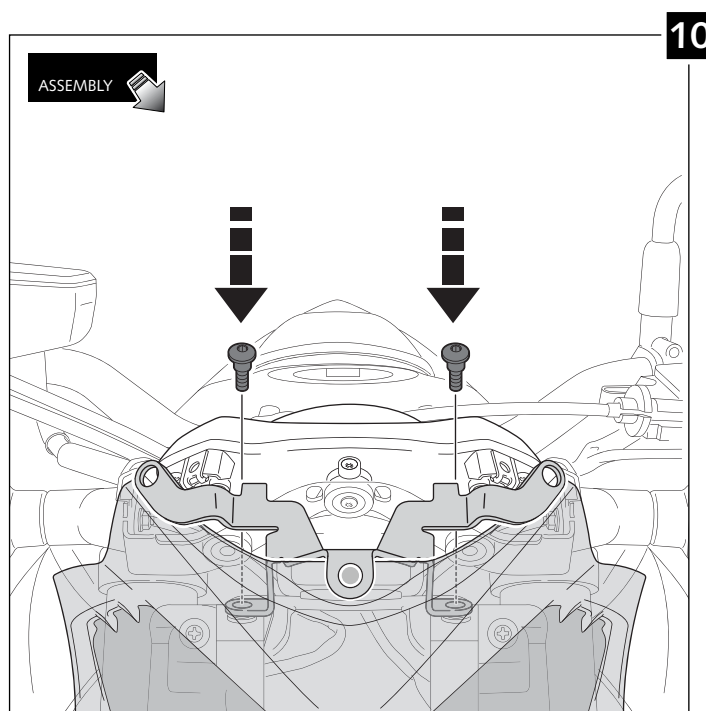
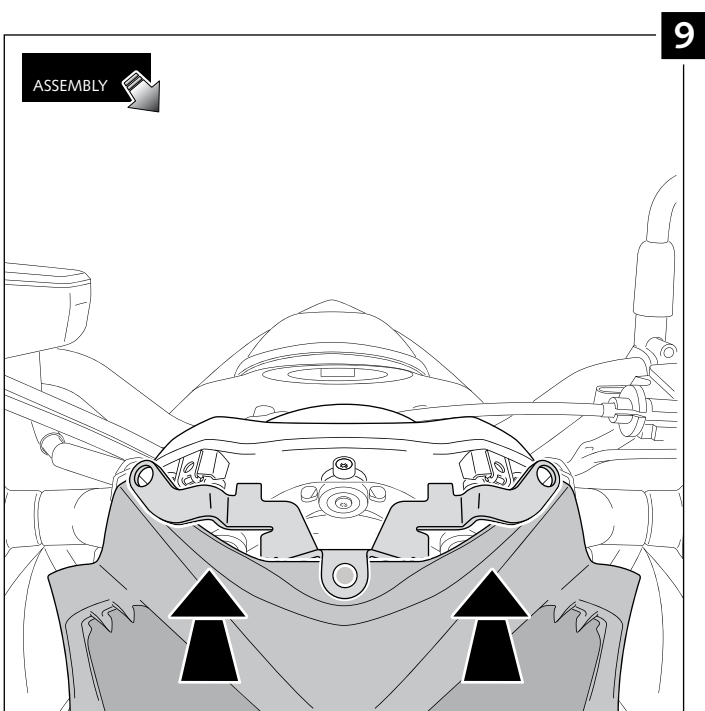



WINDSHIELD FOR  
**SUZUKI GSX-S1000**

MOUNTING INSTRUCTIONS

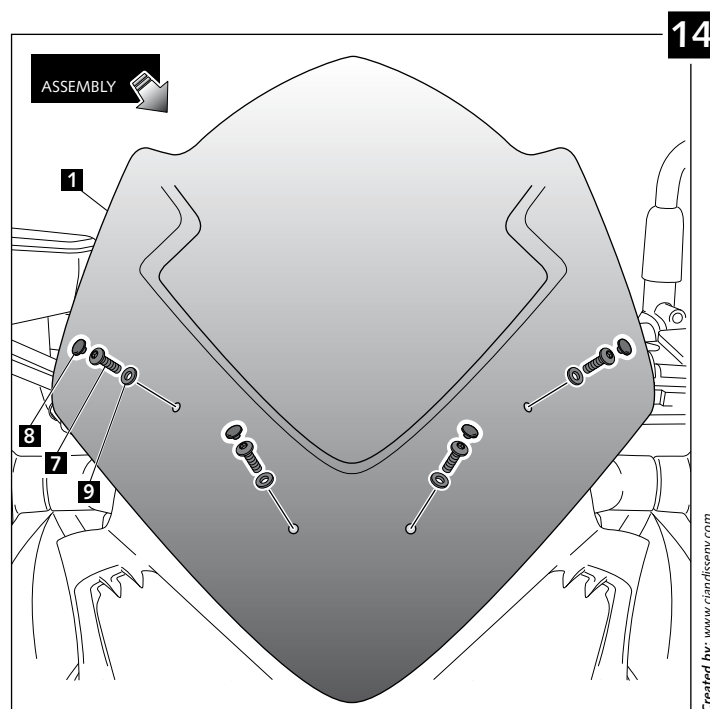
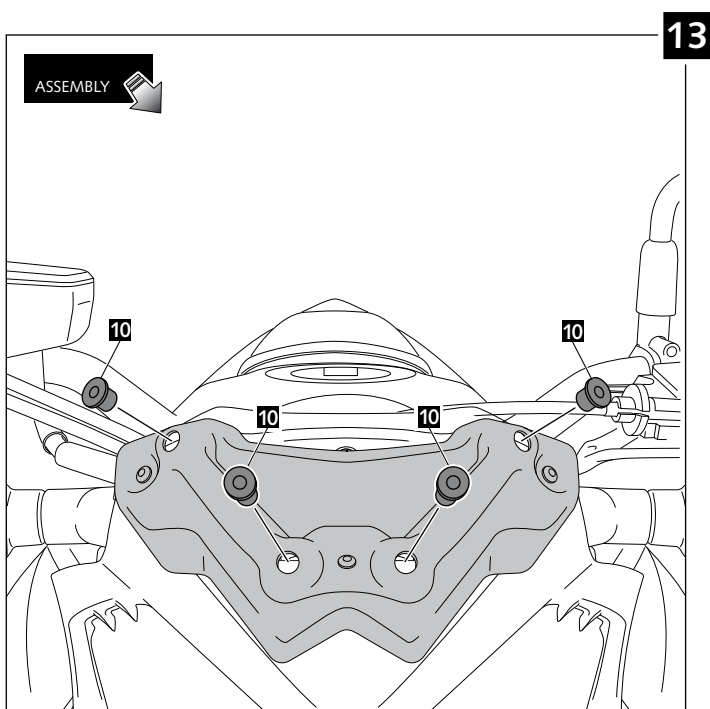

## TIPS FOR A CORRECT WINDSCREEN ASSEMBLY

Due to storage and transport processes of the windscreens, which are subjected to positions and temperature changes out of our control, this may produce small deformations on the material causing some difficulties on the mounting process. It is recommended to:

- 1- Place the screws on one side without tighten all the way.
- 2- Stretch the windscreen to the other side (see Fig. 1). The flexibility of the material allows this stretch with no risk of breaking or cracking.
- 3- Place the screws without tightening all the way.
- 4- Tighten progressively all the screws.

