

## SCREEN FOR KAWASAKI GTR 1400 '15 -

Ref.: 7628

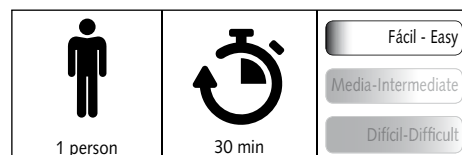
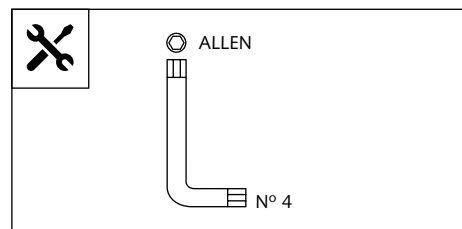
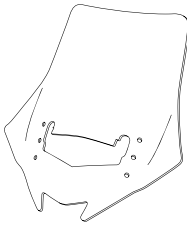

ID	PART	DESCRIPTION	QTY	REF.
1		Screen	1	7628H/F/N/WM3

## SCREEN FOR KAWASAKI GTR 1400 '15 -

### MOUNTING INSTRUCTIONS

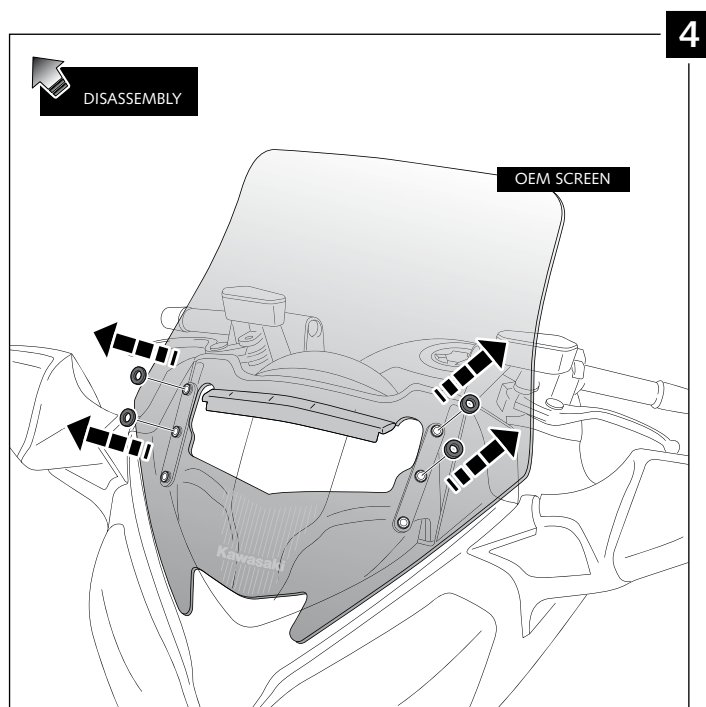
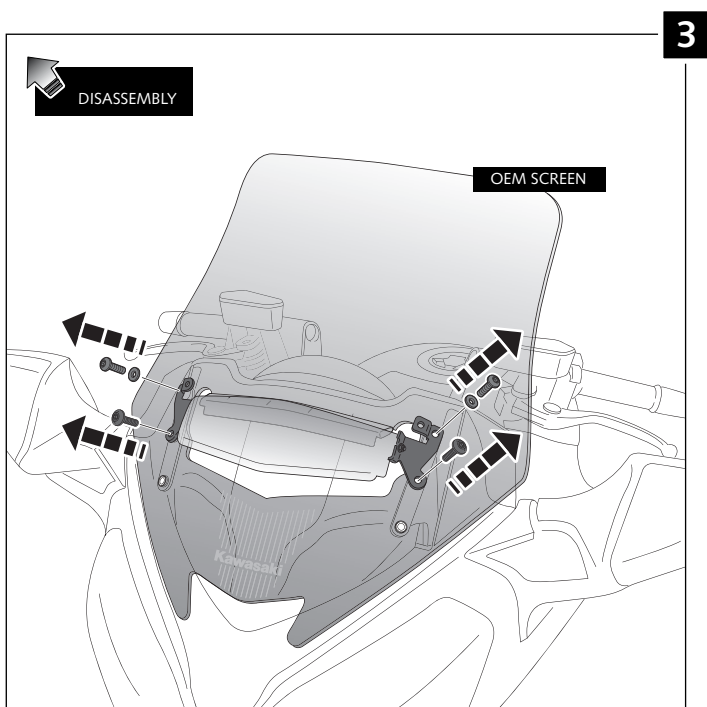
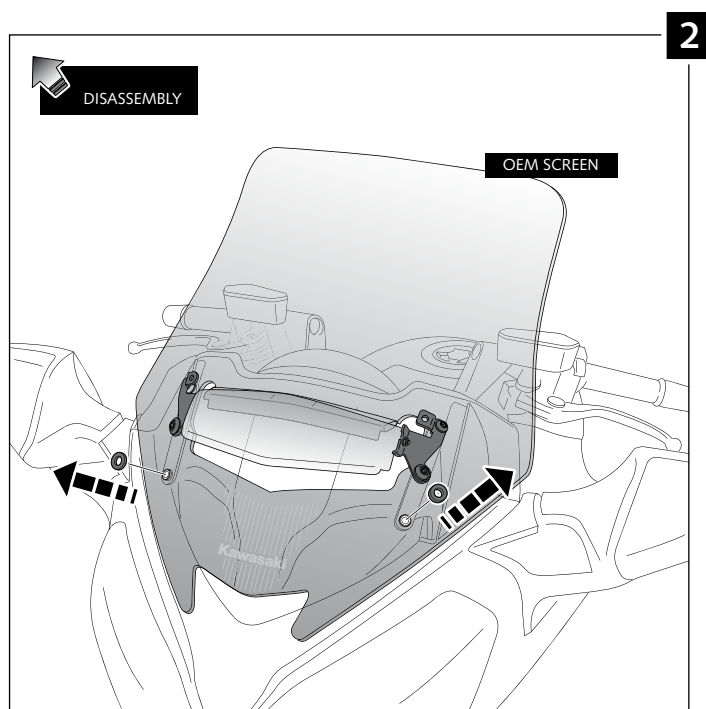
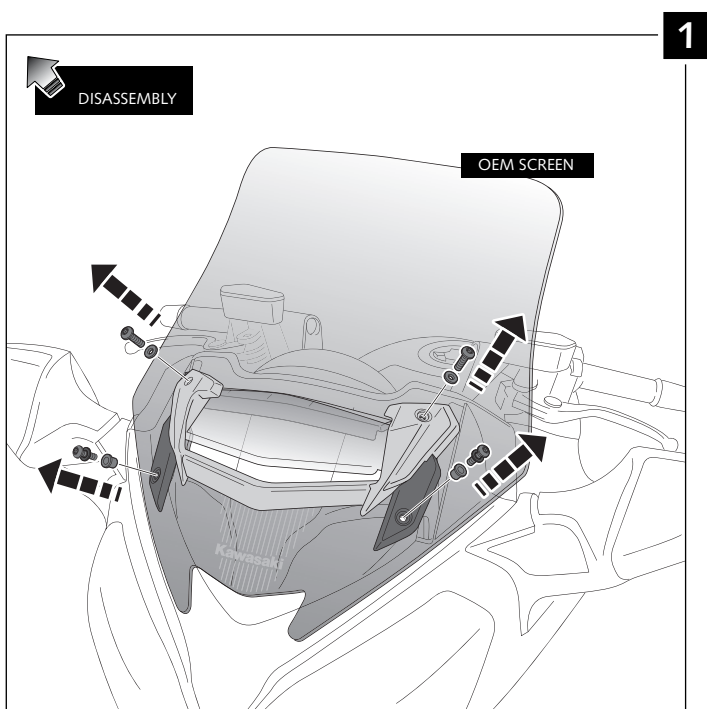



## SCREEN FOR KAWASAKI GTR 1400 '15 -



Ref.: 6007

Ref.: 5852

Ref.: 5853

Smoke

Clear

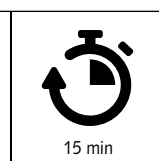
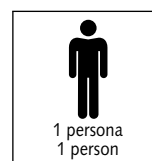
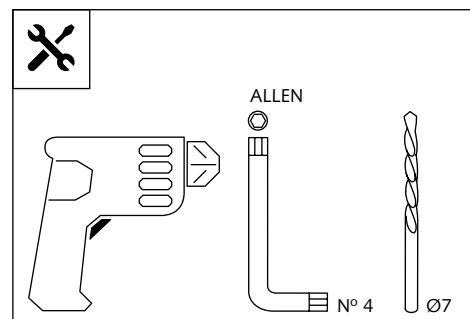

Fácil - Easy

Media-Intermediate

Difícil-Difficult

Note:  
If the visor is supplied along with the windscreen, the windscreen will come factory-drilled so no drilling is necessary.

ID.	PART	DESCRIPTION	QTY.
1		Visor	1
2		Template	1
3		Multi-adjustable mechanism	2
4		Cap	4
5		Plastic thread fastener M6x12	8

## SCREEN FOR KAWASAKI GTR 1400 '15 -

### MOUNTING INSTRUCTIONS

#### TYPE A

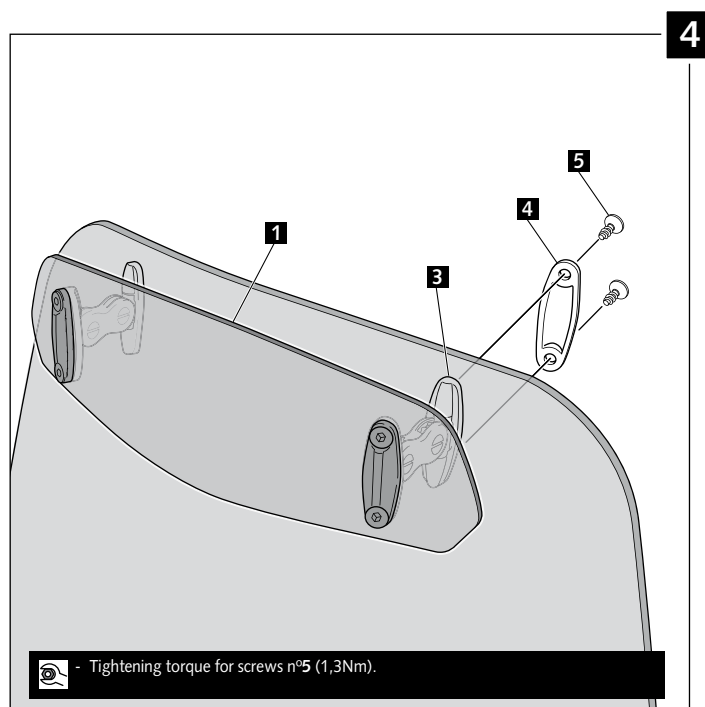
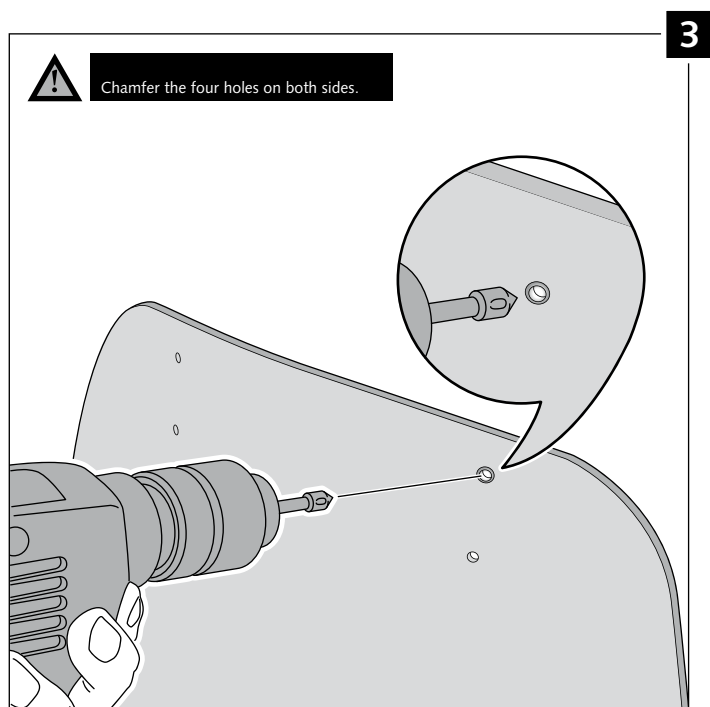
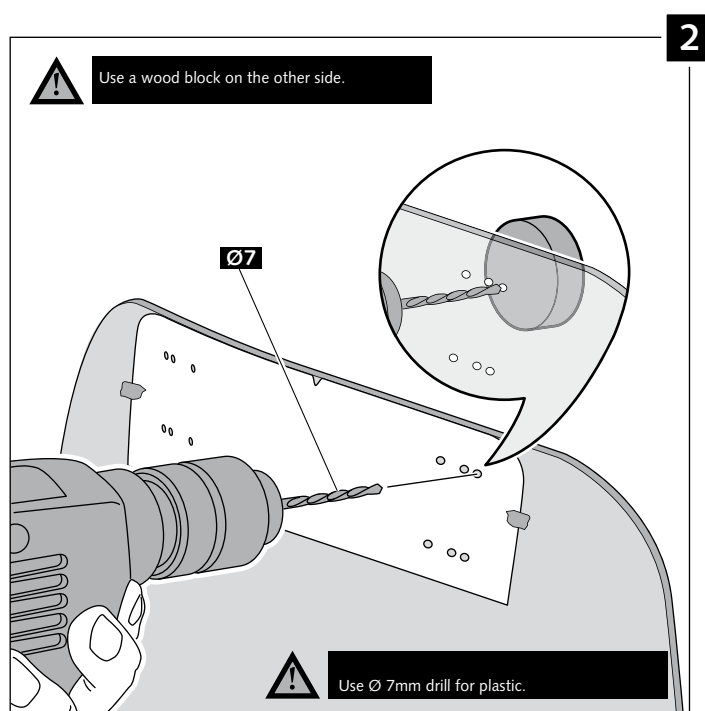
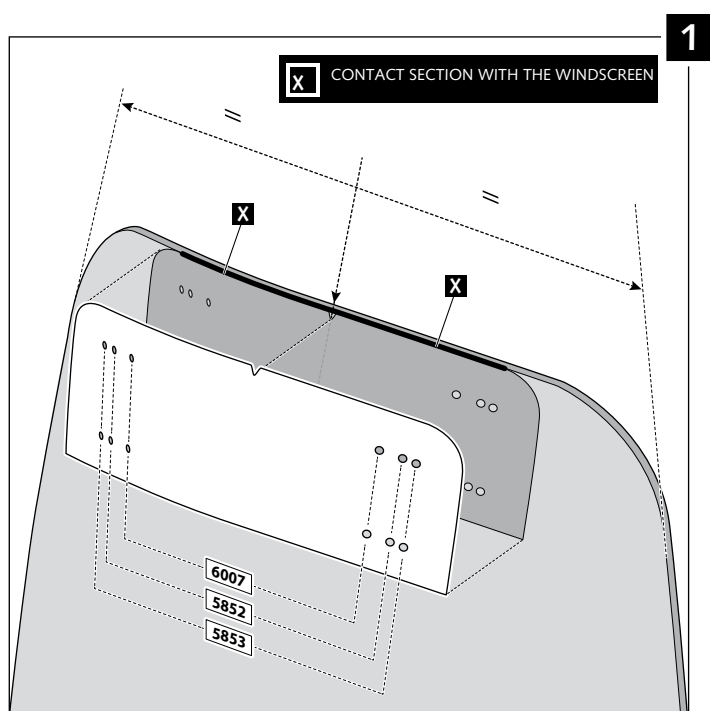

## SCREEN FOR KAWASAKI GTR 1400 '15 -

### MOUNTING INSTRUCTIONS

#### TYPE B

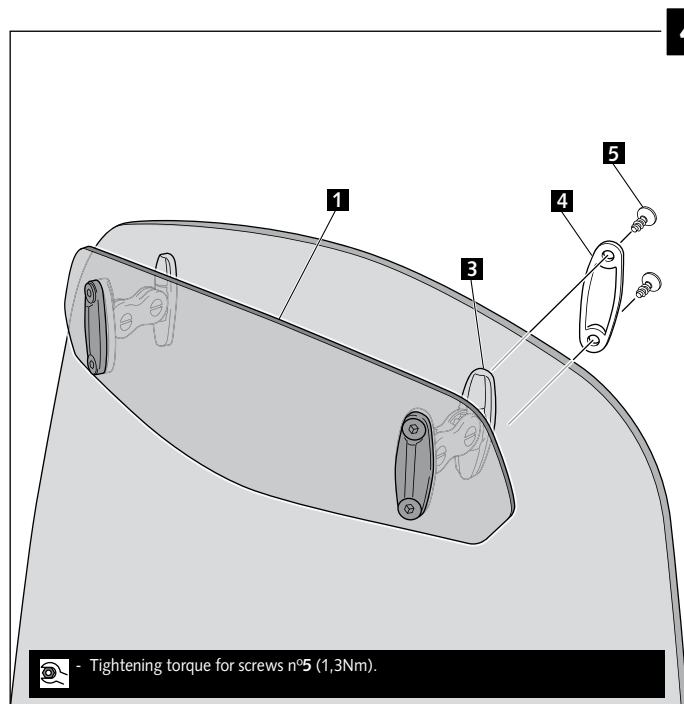
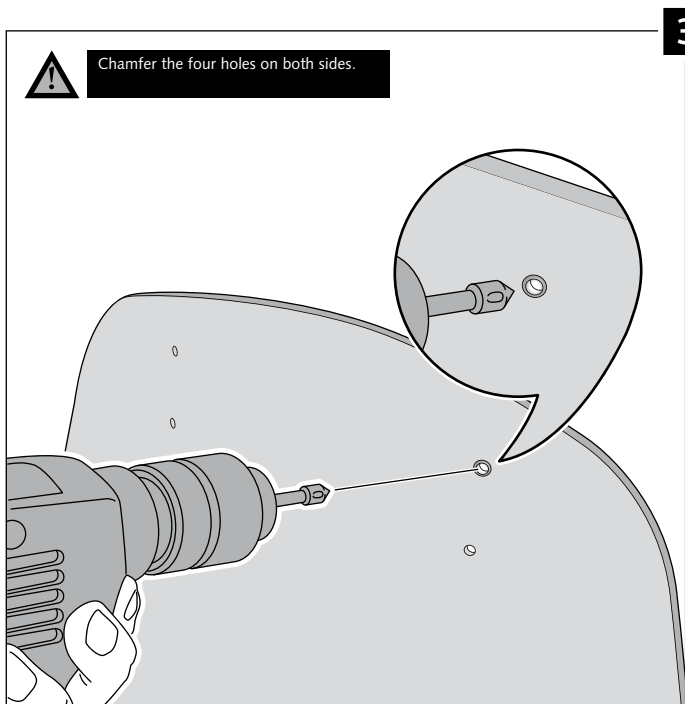
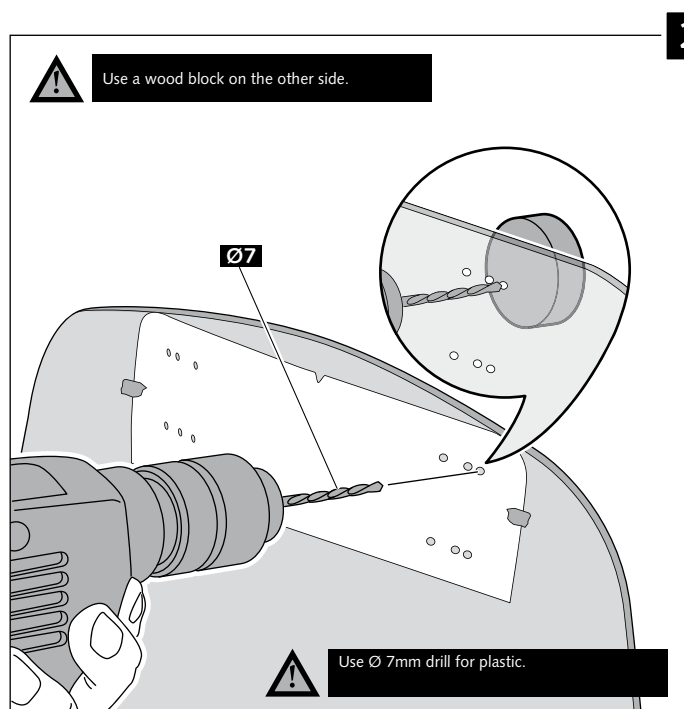
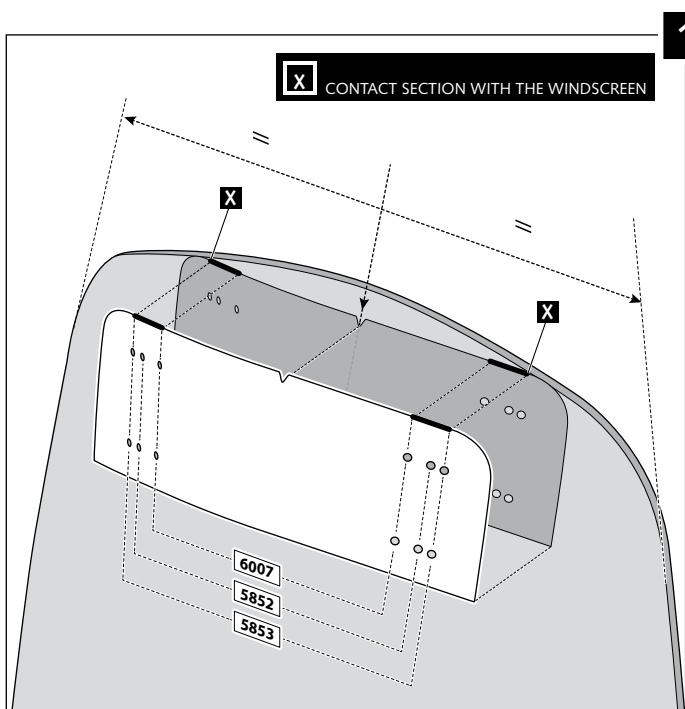

## MULTI-ADJUSTABLE VISOR

### MOUNTING INSTRUCTIONS

#### TYPE C

