

Touring Screen
BMW S1000 XR

Ref. : 7619



ORIGINAL SCREEN RESULTS

HELMET AVERAGE PRESSURE	4.51 g/cm ²
BODY AVERAGE PRESSURE	2.43 g/cm ²

NOTE: g= gram force



PUIG SCREEN RESULTS

HELMET AVERAGE PRESSURE	0.12 g/cm ²
BODY AVERAGE PRESSURE	0.63 g/cm ²



TEST CONDITIONS

SPEED	150 km/h	93 mph
RIDER HEIGHT	180 cm	5.9 ft
RIDER POSITION	Standard	
LATERAL WIND	No	
TEMPERATURE	20°C	68°F

The total dissipated pressure with puig screen is equivalent to 1.973Kg.

85%

IMPROVED AERODYNAMIC WIND PROTECTION WITH PUIG SCREEN

Without losing Cx*

* Aerodynamic drag

BMW S1000XR 15-

Since 1964
Puig
Hi-Tech Parts

Touring windshield

◀◀ Max. protection +105mm (5¹/₈") ▶▶

OEM



TOURING+VISOR 7620H

TOURING 7619F

TOURING 7619H

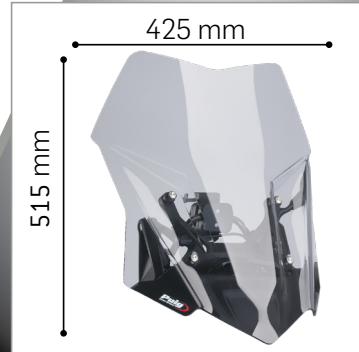

Learn more about motorcycle windshields and fairings we have.