

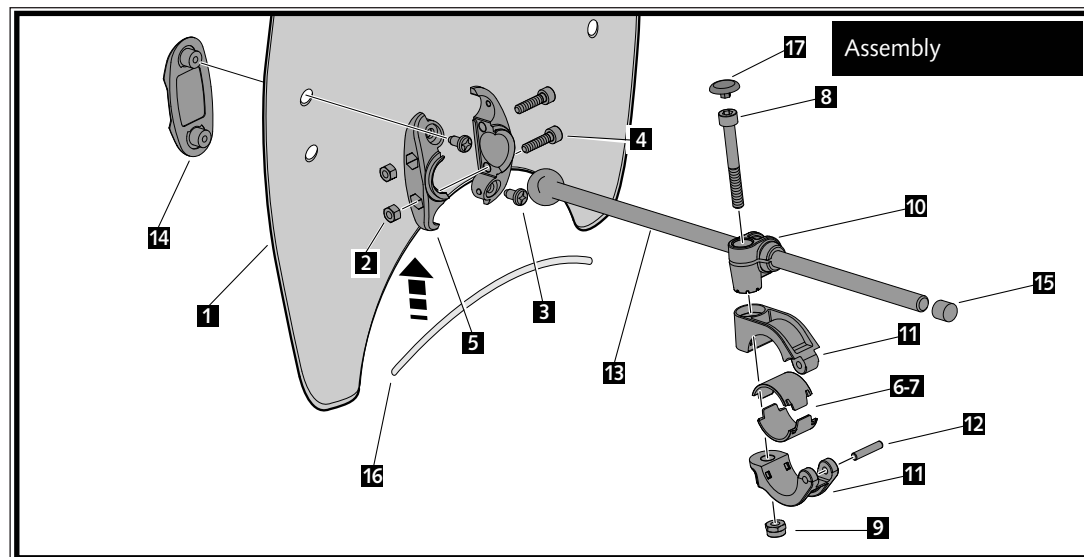

ID.	DESCRIPTION	QTY.
1	Windshield	1
2	M5 DIN982 Inox nut	4
3	M5x13 phillips screw	4
4	M5x20 DIN912 Inox screw	4
5	Ball bearing bridle	2
6	Medium-spacer Ø22mm	2
7	Medium-spacer Ø26mm	2
8	M6x50 DIN912 Inox screw	2
9	M6 DIN982 Inox nut	2
10	Rod guide	2
11	Handlebar bridle Ø29mm	2
12	Barrette Inox	2
13	Rod with ball bearing	2
14	Exterior cap	2
15	Bar cover	2
16	Trim	1
17	M6 DIN912 screw cap	2



MOUNTING INSTRUCTIONS

WINDSHIELD MODEL
CUSTOM II

Ref.: 0336

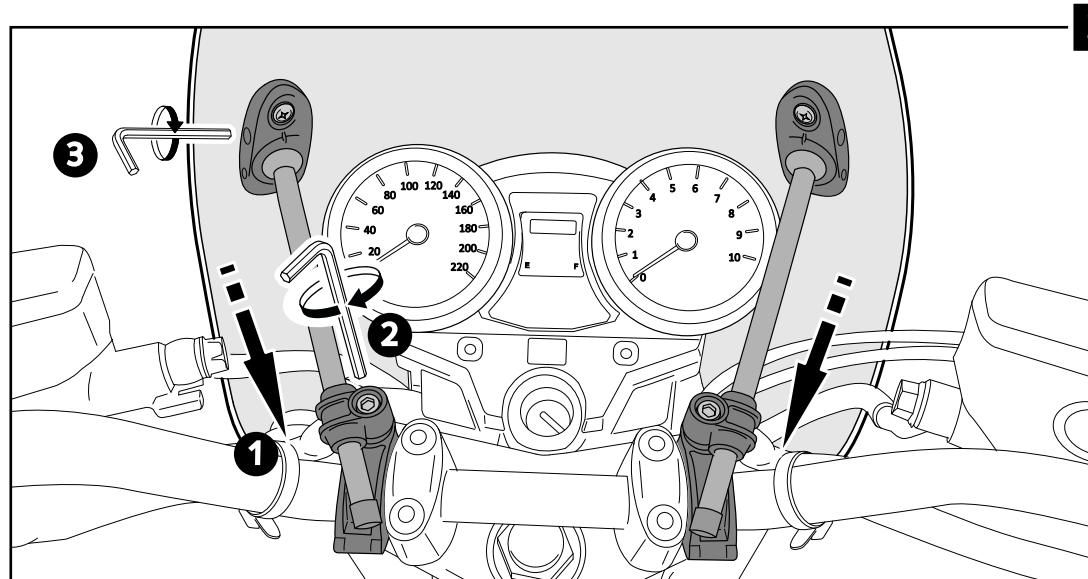
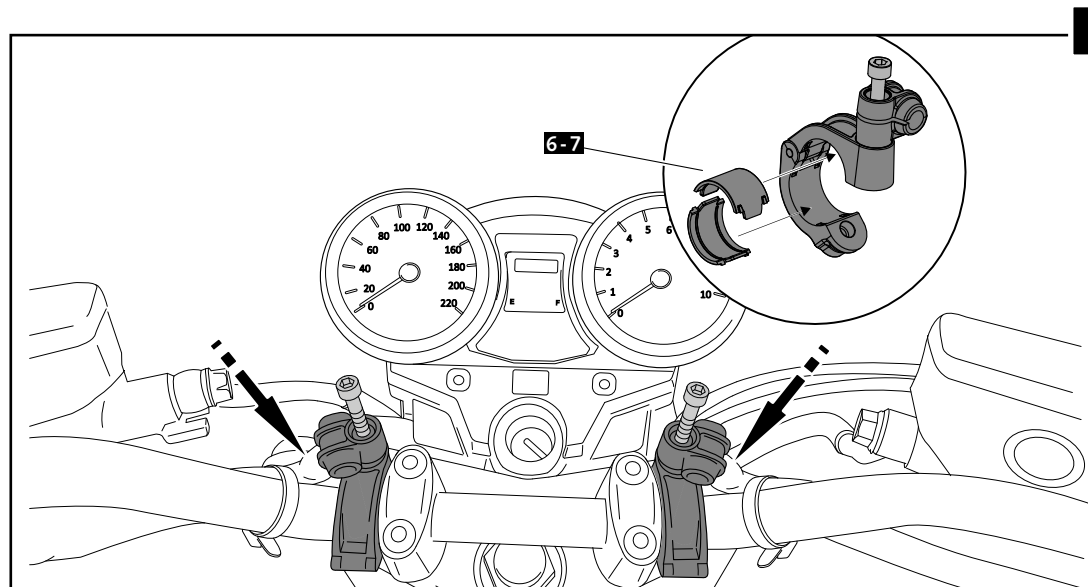
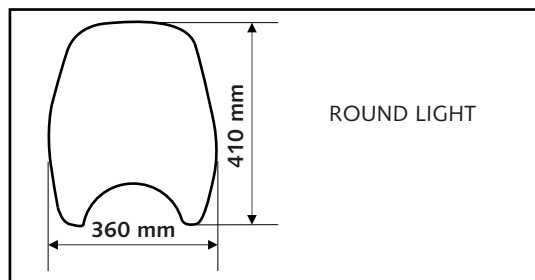

MULTI-ADJUSTABLE VISOR



Ref.: 6007

Ref.: 5852

Ref.: 5853

Smoke

Clear

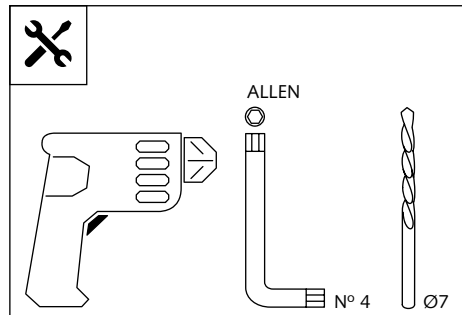

1 person



15 min

Easy

Intermediate

Difficult

Note:

If the visor is supplied along with the windscreen, the windscreen will come factory-drilled so no drilling is necessary.

ID.	PART	DESCRIPTION	QTY.
1		Visor	1
2		Template	1
3		Multi-adjustable mechanism	2
4		Cap	4
5		Plastic thread fastener M6x12	8

MULTI-ADJUSTABLE VISOR

MOUNTING INSTRUCTIONS

TYPE A

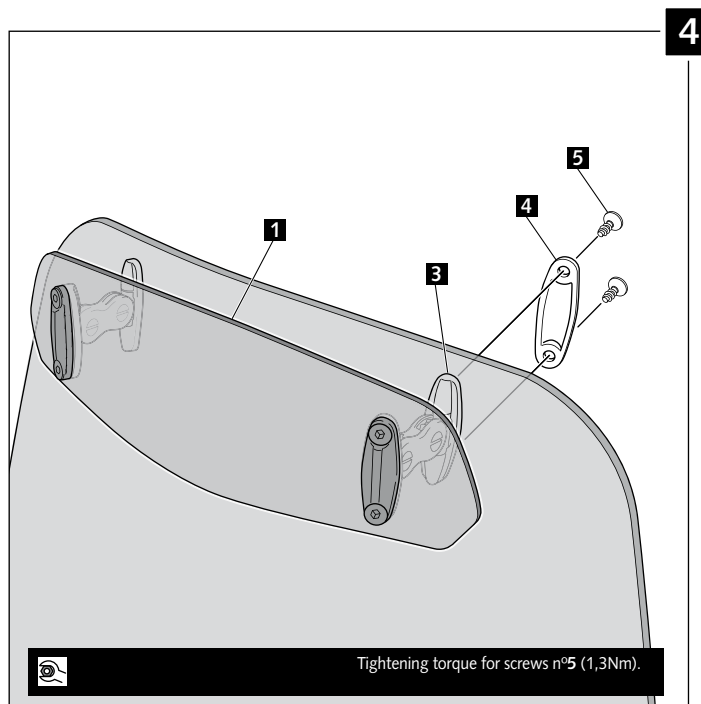
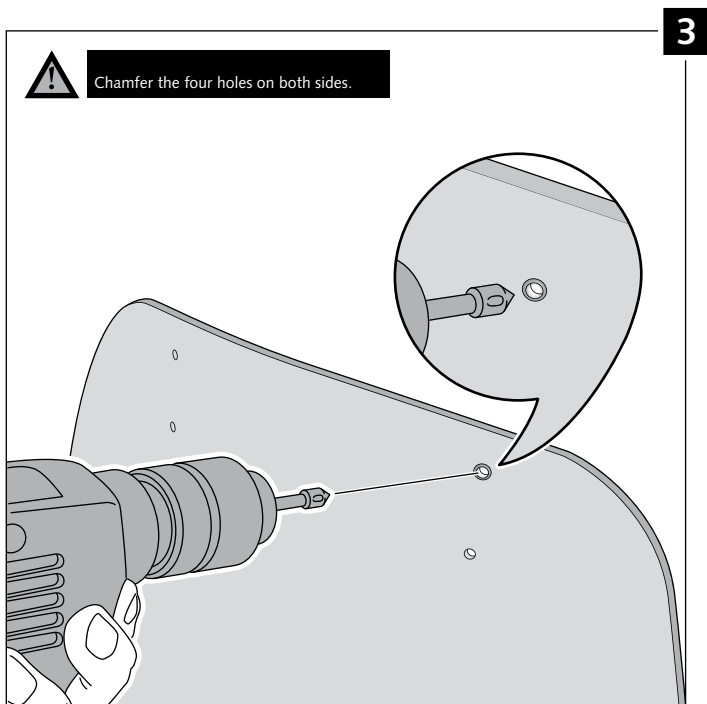
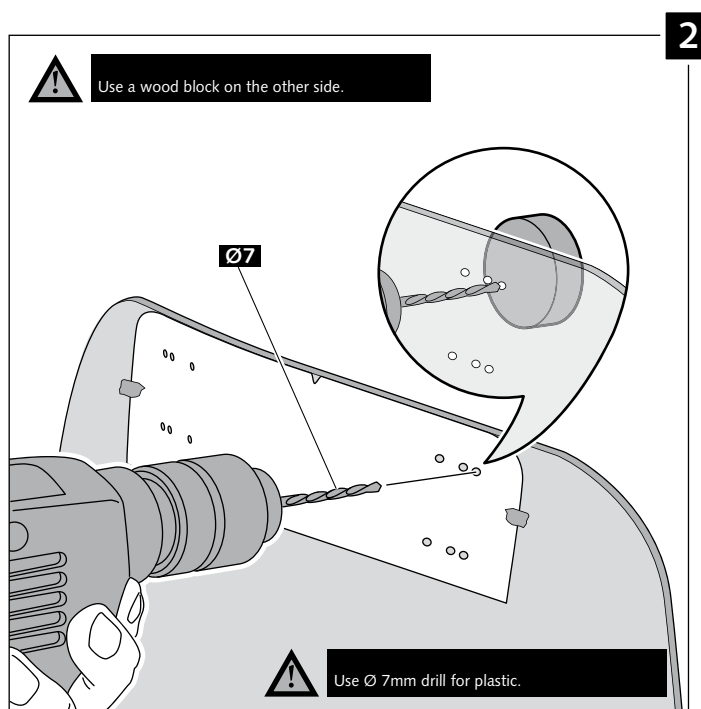
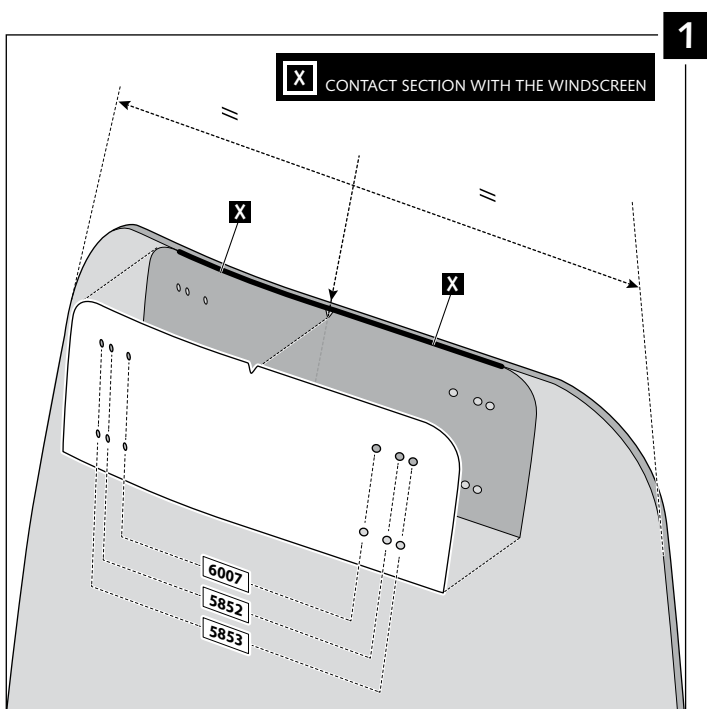

MULTI-ADJUSTABLE VISOR

MOUNTING INSTRUCTIONS

TYPE B

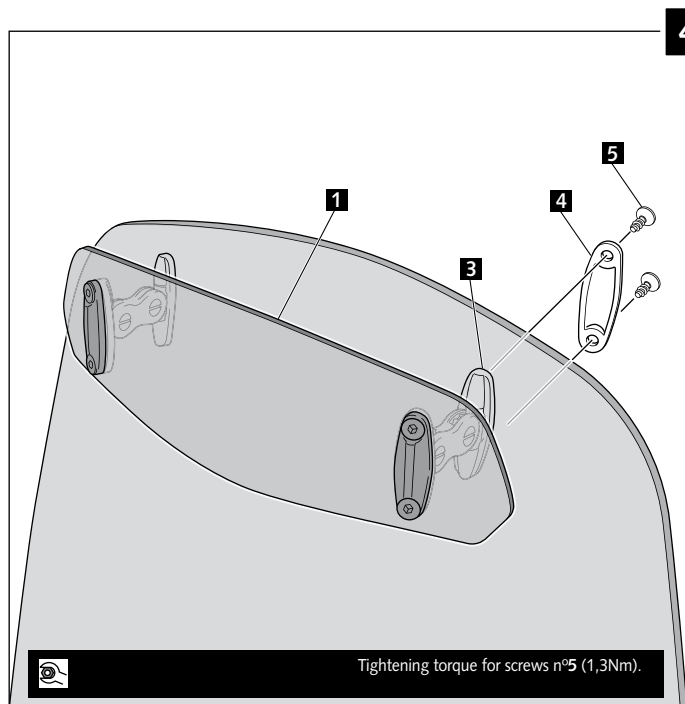
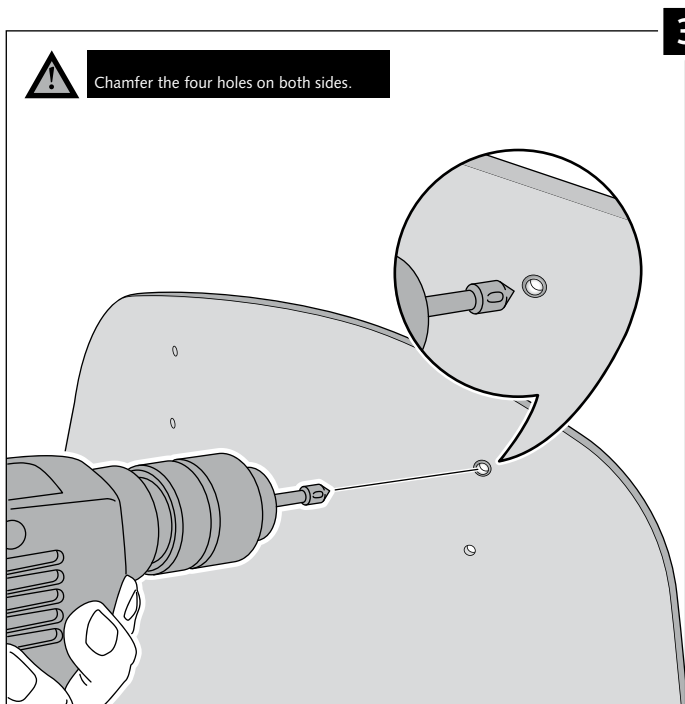
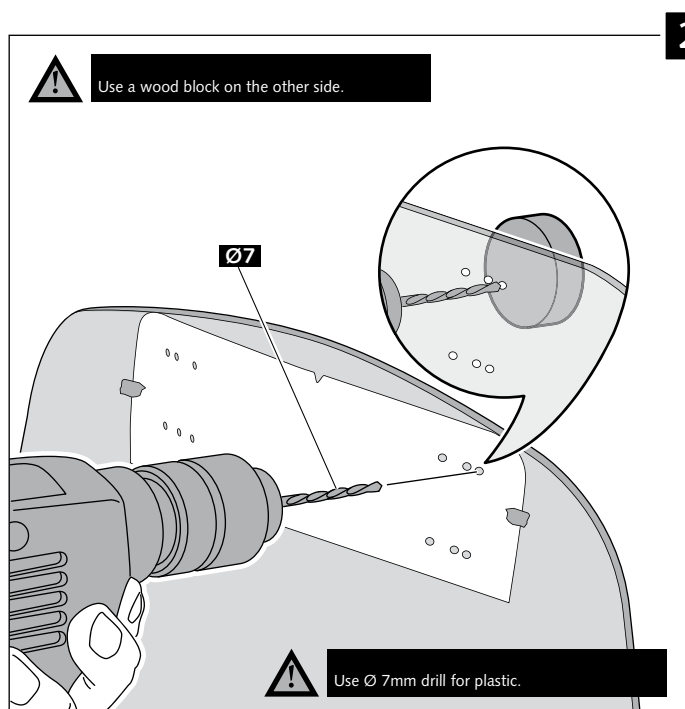
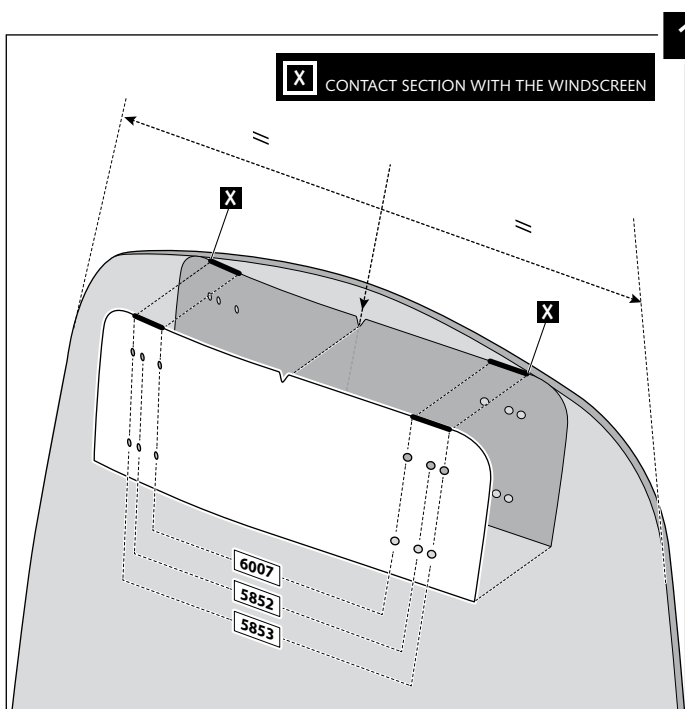

MULTI-ADJUSTABLE VISOR

MOUNTING INSTRUCTIONS

TYPE C

