

## INSTRUCTIONS TO ASSEMBLE

Remove the side bodyworks. Remove the fasteners that subject the chassis to the engine, on the point marked below (and the opposite side). Mount the protectors on each own side as the figure below shows. Tight the set, and place the caps.

All the screws replaced, should be tightened to the torque specified in the oem maintenance manual for your motorcycle. if no torque specifications are provided in the oem maintenance manual, may be used 54Nm for all M10 screws.

Medium strength liquid thread-locker (i.e., "Loctite") should be used to secure all screws, bolts and nuts.

All screws, bolts and nuts should be checked after driving the first 50 km to ensure that all are tightened to the proper torque.

ID.	DESCRIPTION	QTY.
1	Plastic caps	2
2	M10/150X30 DIN912	2
3	M10 DIN6798/A	2
4	M10 DIN125/A	2
5	Nylon protector	2
6	Aluminium metal arrowhead	2
7	Right off set	1
8	Left off set	1
9	M10/150X100 DIN912	1
10	M10/150X80 DIN912	1
11	DIN7505 2,5 X 10	1
12	Sticker	2

FOR TO ASSEMBLE THE CRASH PADS, IF YOU ARE NOT A TRAINED MECHANIC, PLEASE CONTACT A SPECIALIST. MOTOPLASTIC, S.A. TAKES NO RESPONSIBILITY FOR DAMAGES CAUSED BY IMPROPER INSTALLATION. THE USE OF CRASH PADS DO NOT GUARANTEE A FULL PROTECTION IN CASE OF ACCIDENT. MOTOPLASTIC-PUIG DECLINE ANY RESPONSIBILITY IN CASE OF MOTORCYCLE DAMAGE.

## MOUNTING INSTRUCTIONS

### CRASH PADS FOR APRILIA RSV4 '09 - '12

Ref.: 5578

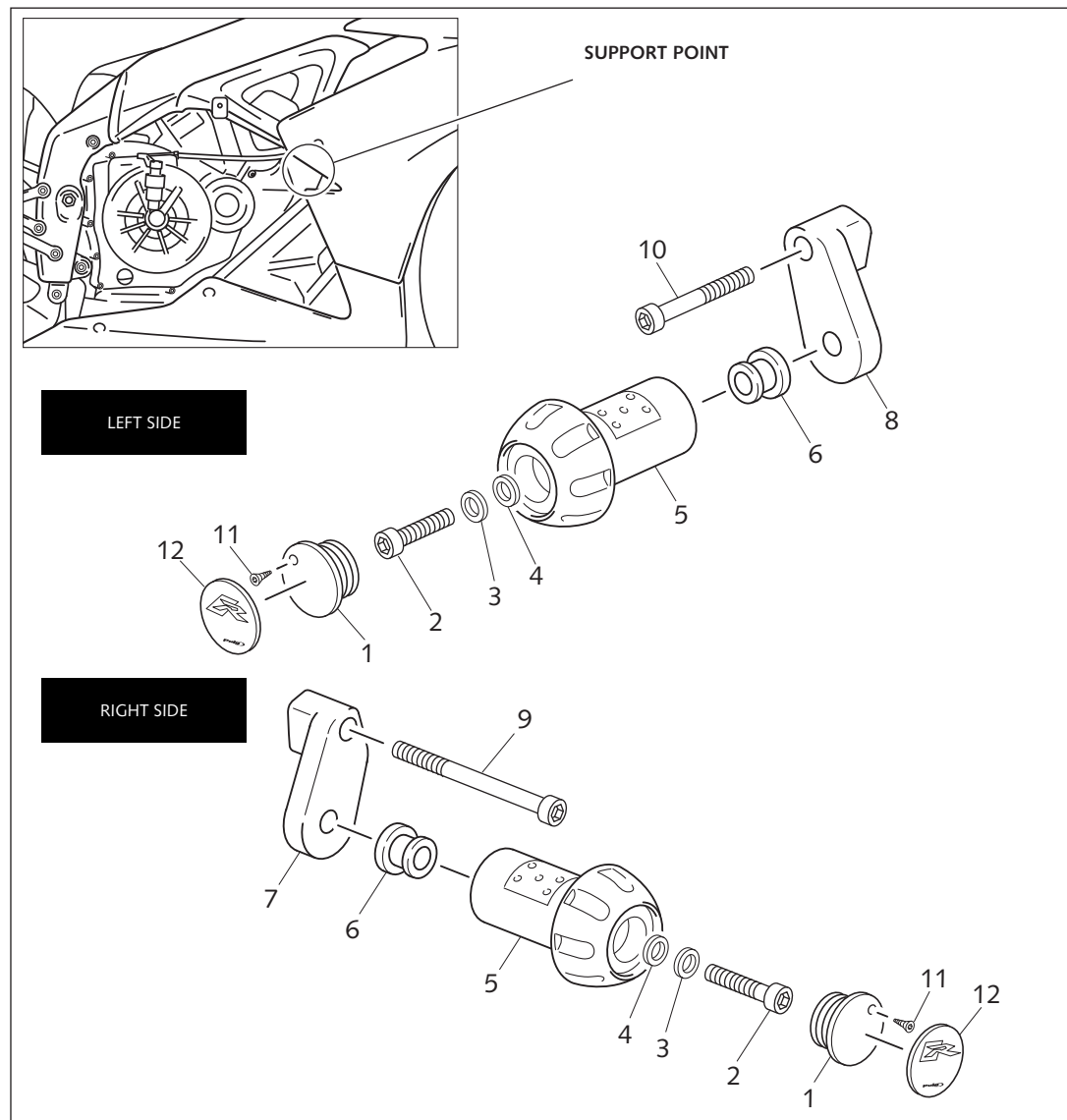

Learn more about motorcycle frame and body we have.