

# HUGGER ADAPTABLE TO HONDA VFR1200F 10'-



REF: 5276

## INSTRUCTIONS TO ASSEMBLE

- 1- Remove the plastic caps (A and B) and the screw (C).
- 2- Mount the hardware on positions A and B, using the M6x10 screws (2 and 3) supplied.
- 3- Place the wellnuts on the rear hugger supplied and the aluminium cylinder (5) on position C. Tighten the hugger using the M6x25 screw (4) on position C, and the M6x20 screws (6) on position 7 and 8.
- 4- Adjust the hugger through the regulation that the positions 7 and 8 offer
- 5- Check them periodically and tight the fixations.
- 6- In case your motorcycle has other accessories, observe that it does not interfere with the hugger.

## Material supplied to assemble the hugger:

POSITION	DESCRIPTION	QTY
1	Hardware	1
2/3	M6x10 DIN933	2
4	Black M6x25 screws DIN1001	1
5	Aluminium cylinder Ø16x5	1
6	Black M6x20 screws DIN1001	2
7/8	M6 special locknuts DIN6923	2
9	Wellnuts	3

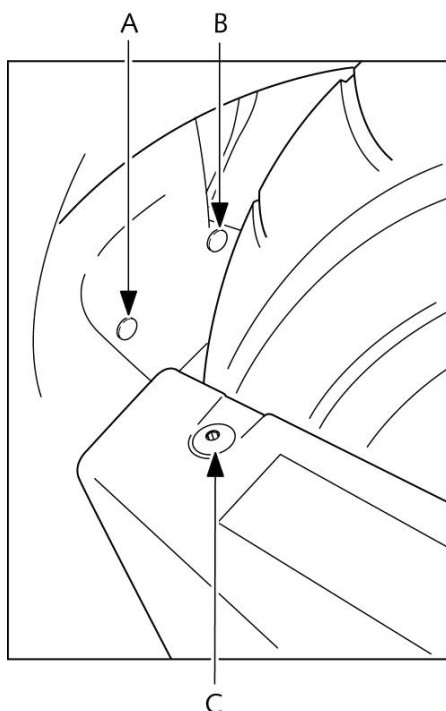

FIGURE 1

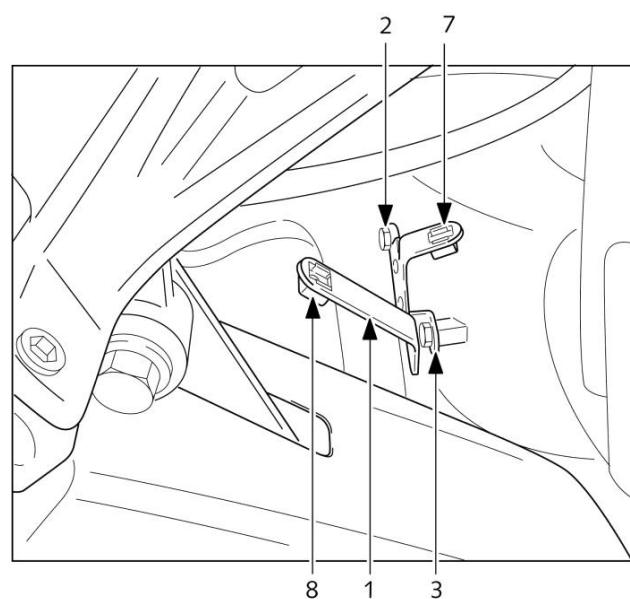

FIGURE 2