

CRASH PADS FOR KAWASAKI ER6n

REF:4069



INSTRUCTIONS TO ASSEMBLE

1. Remove the fasteners that fix the chassis to the engine (mark on the picture below).
2. Mount the plate-protector set on its own side (using the 11 and 12 fasteners with the original nuts), so the plate supplied is over the motorcycles' plate.
3. To ease the process, it is recommended to remove the side bodyworks as well as the protector of the fixation plate.
4. Once pressed, place the caps (1).

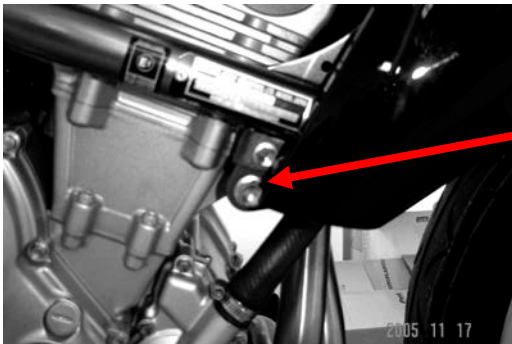

SUPPORT POINT

MATERIAL SUPPLIED

POSITION	DESCRIPTION	QUANTITY
	Plastic caps	2
2	M10/150x45 screw	1
3	M10/150x100 screw	1
4	∅20ext.∅10int x2 washer	2
5	Nylon protector 85mm	2
6	Aluminium metal arrowhead right hand side	1
7	Aluminium metal arrowhead left hand side	1
8	Right Iron Plate	1
9	Left Iron Plate	1
10	M10/150 locknut din 982.8	2
11	M10/125 x100 screw	1
12	M10/125 x50 screw	1

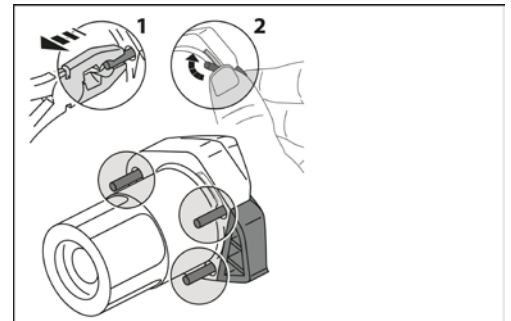
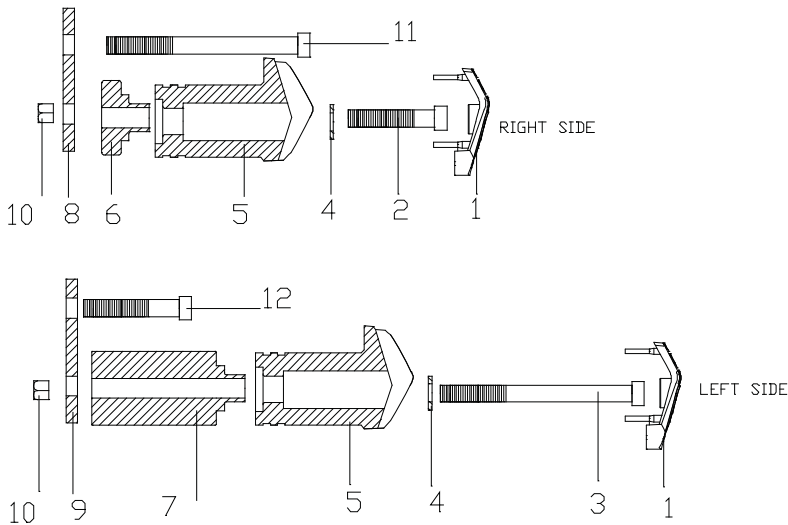

THE USE OF CRASH PADS DO NOT GUARANTEE A FULL PROTECTION IN CASE OF ACCIDENT. MOTOPLASTIC-PUIG DECLINE ANY RESPONSIBILITY IN CASE OF MOTORCYCLE DAMAGE.