

ELECTRONIC REGULABLE SYSTEM (E.R.S.)

TRIUMPH TIGER 800 XC/XR/XRX/XRT/XCX/XCA '18-'19

M O U N T I N G I N S T R U C T I O N S

REF 3654



1 Person



60 min



MEDIUM



TORX
T° 30

ALLEN
N° 3
N° 5
N° 6

N° 10
N° 14

ID	PART	DESCRIPTION	QTY	REF
1		ERS	1	ERS1UNIVERSAL
2		Right screen support	1	SOPOR7P8-SR3654
3		Left screen support	1	SOPOR7P8-SL3654
4		Right deflector	1	SOPOR7P8-DR3654
5		Left deflector	1	SOPOR7P8-DL3654
6		Right LOWER support	1	SOPOR7P8-IR3654
7		Left LOWER support	1	SOPOR7P8-IL3654
8		Box switch + support	1	ERS1UNIVERSAL
9		Intensity box limiter	1	ERS1UNIVERSAL
10		TRIUMPH power cable	1	3654
11		Ø4,5 x Ø11 x 2mm rubber washer	4	ARAND-EPDM--722
12		M5 nylon washer	4	ARNV0000000245
13		M5x11 Ø11 ISO 7380 Allen screw	8	TORNI-AI----520
14		M5 ISO 7380 screw cap	4	TAPON-----85
15		M5x10 DIN7991 Allen screw	4	TORNI-D7991-808
16		M6 nut cap	4	CAPERUTUM6-21/1
17		M6 lock nut	4	TUZBM6000000024

ELECTRONIC REGULABLE SYSTEM (E.R.S.)

TRIUMPH TIGER 800 XC/XR/XRX/XRT/XCX/XCA '18-'19

MOUNTING INSTRUCTIONS

1

ASSEMBLY

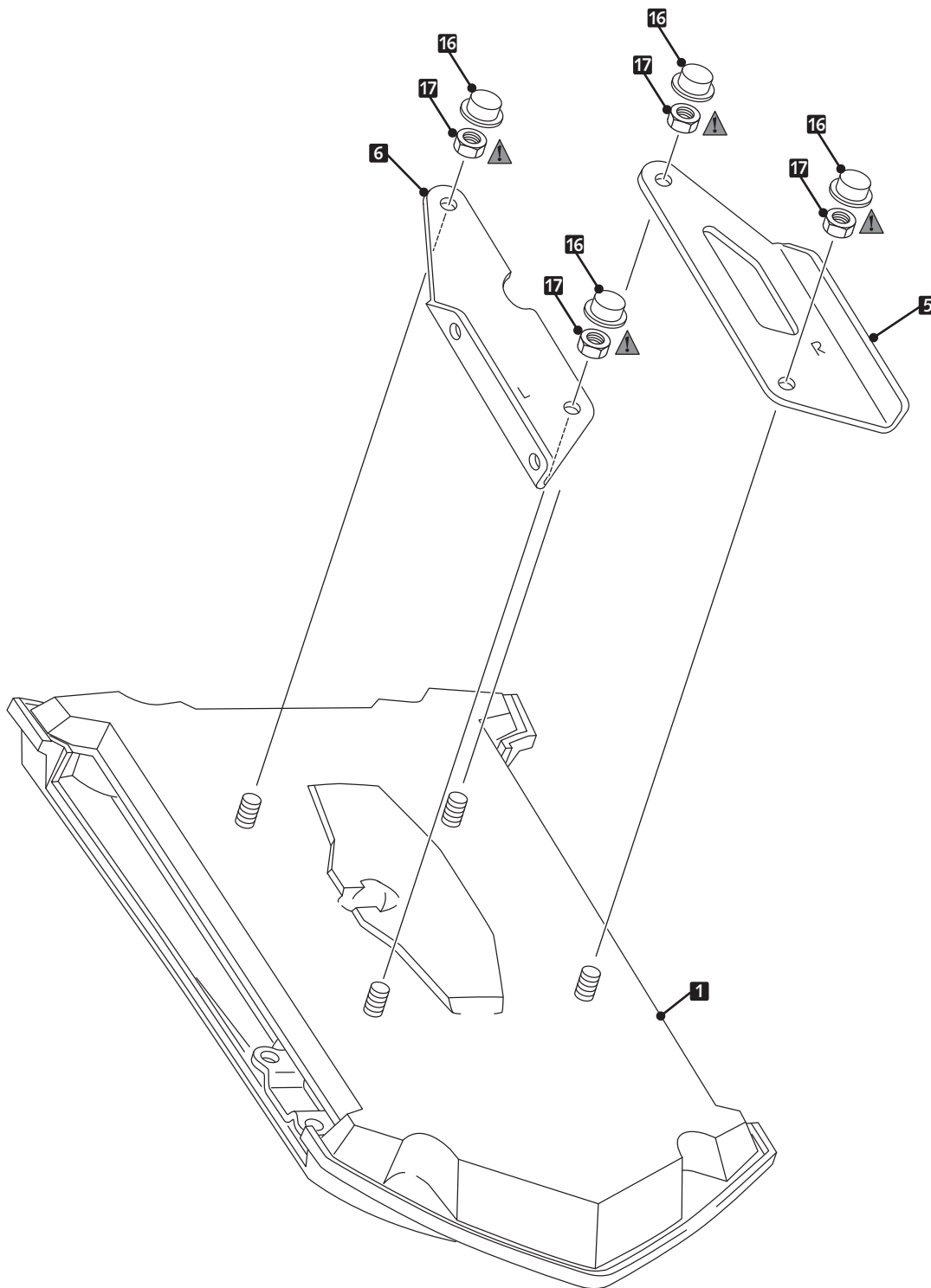

TIGHTENING TORQUE 7Nm

ELECTRONIC REGULABLE SYSTEM (E.R.S.)
TRIUMPH TIGER 800 XC/XR/XRX/XRT/XCX/XCA '18-'19

MOUNTING INSTRUCTIONS

2

ASSEMBLY

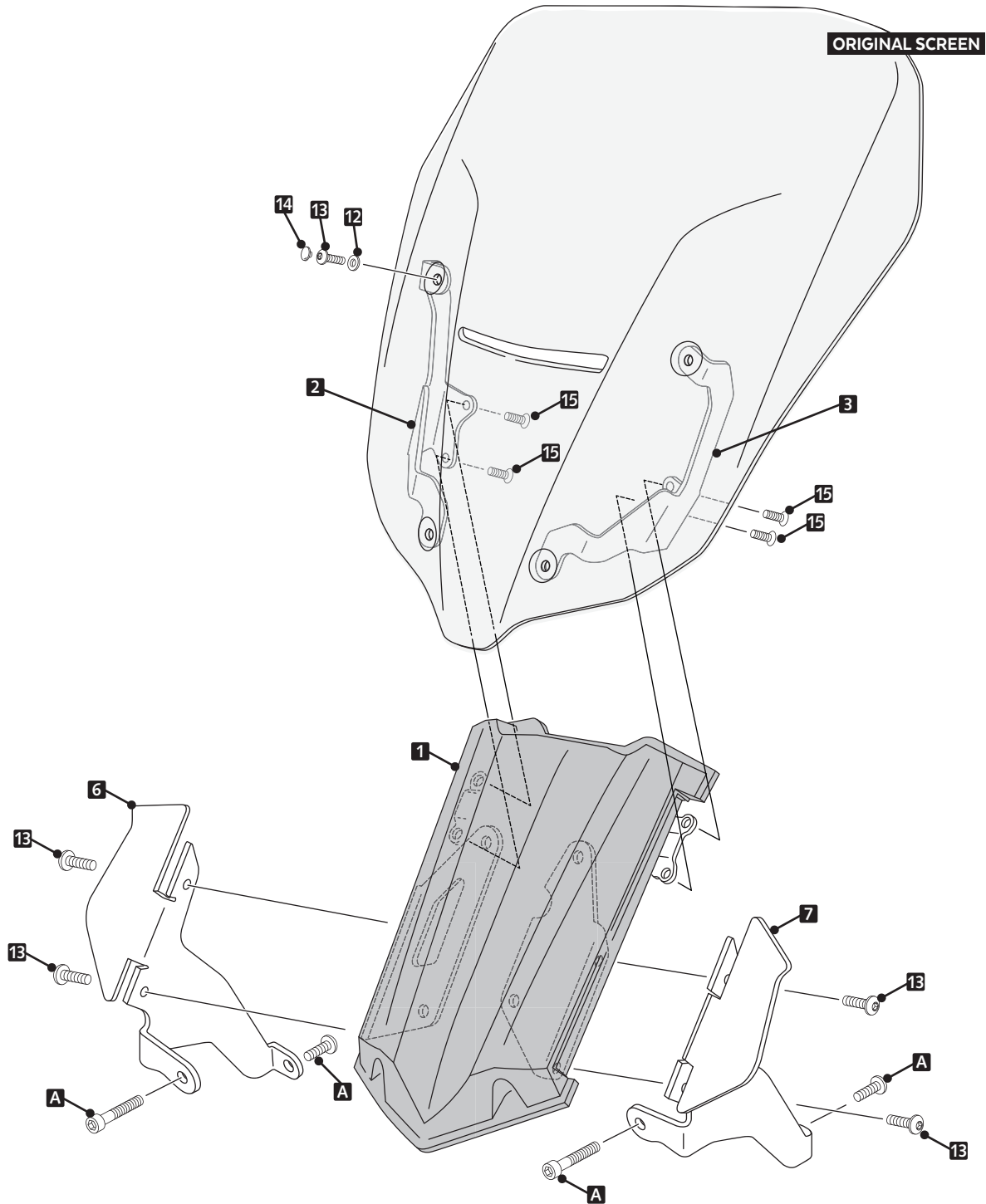

A ORIGINAL PART

WIRING DIAGRAM

REF 3654

