

CRASH PADS ADAPTABLE TO YAMAHA TDM 900 02-13'

REF: 1874



INSTRUCTIONS TO ASSEMBLE

Dismount the fixation screws from the chassis to the engine in the support point marked on the picture (and the opposite side). Mount the crash pads on each own side as the figure shows, using the supplied screws. Once pressed, place the lids (1).

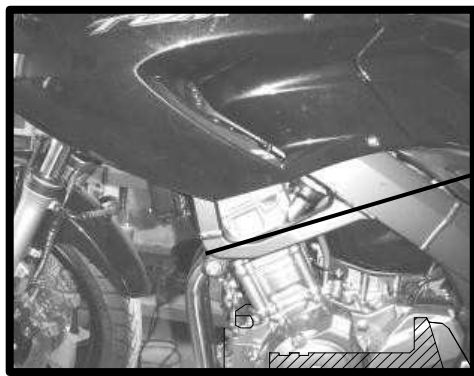

PUNTO DE FIJACIÓN

SUPPORT POINT

BEFESTIGUNGSPUNKT

MATERIAL SUMINISTRADO / MATERIAL SUPPLIED / LIEFERUMFANG

LADO DERECHO
RIGHT SIDE

POSICION/POSITION/NUMMER	DESCRIPCIÓN/DESCRIPTION/BEZEICHNUNG	CANTIDAD/QUANTITY/MENGE
1	Tapón de plástico// Plastic lids// Kunststoff-Endkappe	2
2	Tornillo M12/125x80 DIN912// M12/125x80 screw// Schraube M12/125x80 DIN 912	1
3	Tornillo M12/125x90 DIN912// M12/125x90 screw// Schraube M12/125x90 DIN 912	1
4	Arandela Ø20 ext. Ø12,5 int. Ø12,5// M2 DIN125/A// Ø20 ext. Ø12,5 int. Ø12,5 x 2 washer// IZQUIERDO LEFT SIDE	2
5	Protector Nylon// Nylon protector// Nylonkörper	2
6	Casquillo aluminio //derecho// Aluminium metal arrowhead right hand side// Aluminiumhülse - Rechte Seite	1
7	Casquillo aluminio //izquierdo// Aluminium metal arrowhead left hand side// Aluminiumhülse - Linke Seite	1

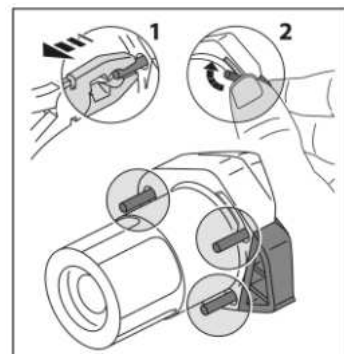
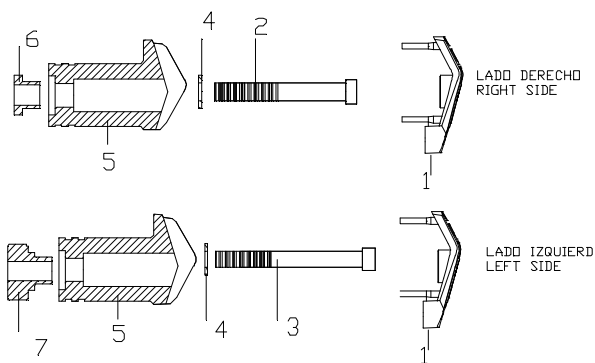

El montaje de los protectores de motor no garantizan una protección integral en caso de caídas. Motoplasic, S.A. declina toda responsabilidad en caso de deterioro de la motocicleta.

If you are not a trained mechanic, please contact a specialist for assembling the crash pads. Motoplasic, S.A. takes no responsibility for damages caused by improper installation. The using of crash pads does not guarantee a full protection in case of accident.

Wenn Sie kein ausgebildeter Mechaniker sind, wenden Sie sich bitte an Ihre Fachwerkstatt. Motoplasic, S.A. übernimmt keine Haftung für Schäden, die durch eine unsachgemäße Montage der Sturzpads verursacht werden. Hinweis: Die Benutzung von Sturzpads garantiert keinen vollständigen Schutz bei eventuellen Unfällen.