

CRASH PADS FOR YAMAHA FAZER 600 '04
REF:1873



INSTRUCTIONS TO ASSEMBLE

Dismount the fixation screws from the chassis to the engine in the support point marked on the picture (and the opposite side). Mount the crash pads on each own side as the figure shows, using the supplied screws. Once pressed, place the lids (1).



SUPPORT POINT

MATERIAL SUPPLIED

POSITION	DESCRIPTION	QUANTITY
1	Plastic lids	2
2	M10/125 x70 screw	1
3	M10/125 x80 screw	1
4	Washer Ø20ext.Ø10int x2	2
5	Nylon protector	2
6	Aluminium metal arrowhead right hand side	1
7	Aluminium metal arrowhead left hand side	1

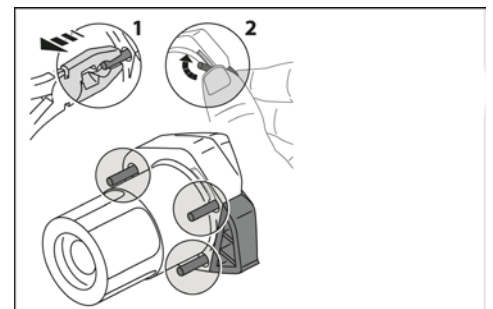
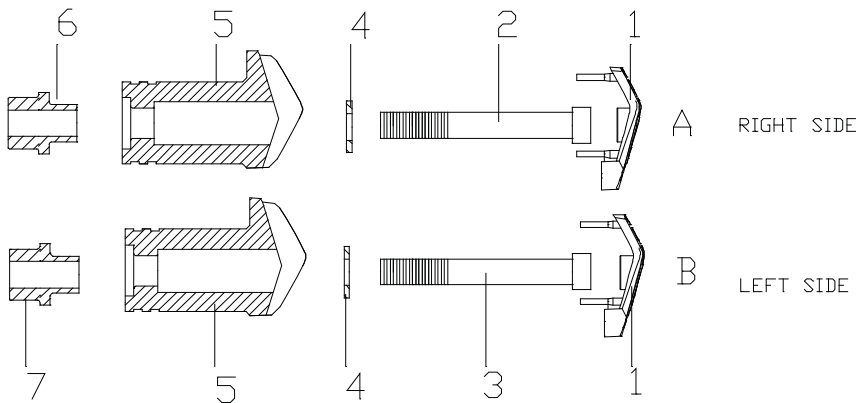

THE USE OF CRASH PADS DO NOT GUARANTEE A FULL PROTECTION IN CASE OF ACCIDENT. MOTOPLASTIC-PUIG DECLINE ANY RESPONSIBILITY IN CASE OF MOTORCYCLE DAMAGE.

Learn more about motorcycle frame and body we have.