

TECHNICAL FEATURES

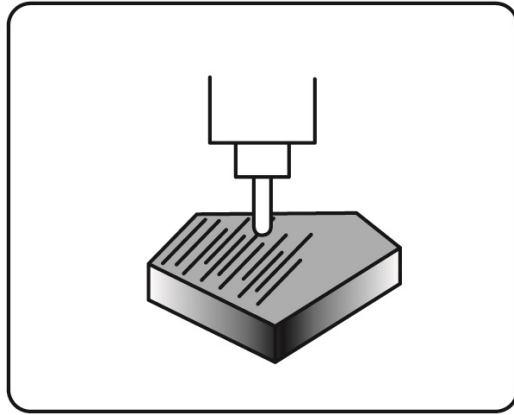

MATERIAL

Machined from an aluminum block and posterior anodized

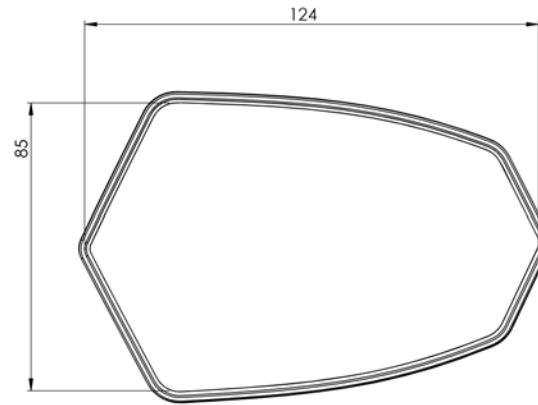

APPROVED

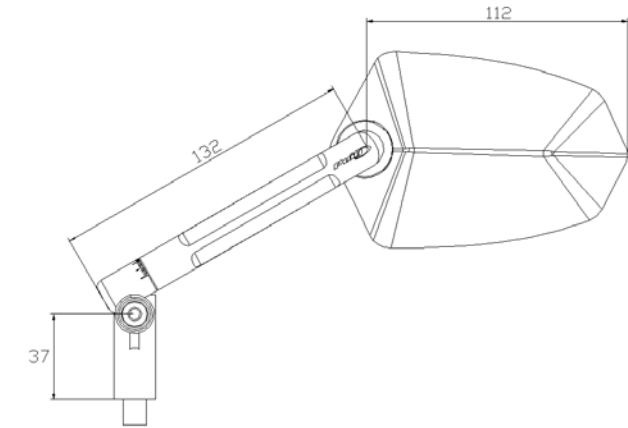

SUITABLE

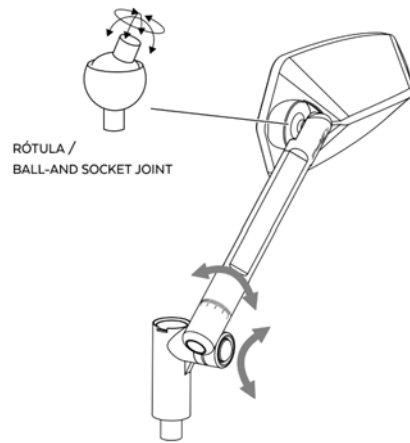

REGULABLE