



SUPER GAS AIR CLEANER



PM SuperGas Design Matched Faceplate Upgrade

Note: Use blue Loctite on all fasteners during assembly.

1. Turn off motorcycle, extinguish all cigarettes and open flames, place motorcycle securely on the side stand or lift.
2. Remove five 1/4-20 bolts holding the universal outer ring on. Safely contain all the spacers and components, you will reuse most of them.
3. Remove and set aside the plastic spacer ring, this ring will be replaced by the new designed matched Supergas face plate (15).
4. Disassemble and set aside the beauty washer, 1/4-20 flat head cap screw, and 1/4-20 locknut originally installed on the air filter element. (Will not be reused)
5. Install the new Supergas design matched face plate (15) into the universal outer ring (9) making sure the o-ring is properly positioned in the groove.
6. Assemble and position the universal outer ring, Supergas face plate, mesh insert (7), foam ring (14), air filter (3), and secondary plate as an assembly.
7. Using the original 1/4-20 x 2.5" bolts (2) and spacers (10) secure the air filter assembly. Before tightening the bolts index the Supergas plate to the desired orientation. Torque the bolts to 8 ft-lbs.
8. Apply the desired PM adhesive badge to the center of the Supergas face plate. PM has supplied two badges, one silver and one black.
9. Fire up your "Performance Machine" and hit the road.





SUPER GAS AIR CLEANER

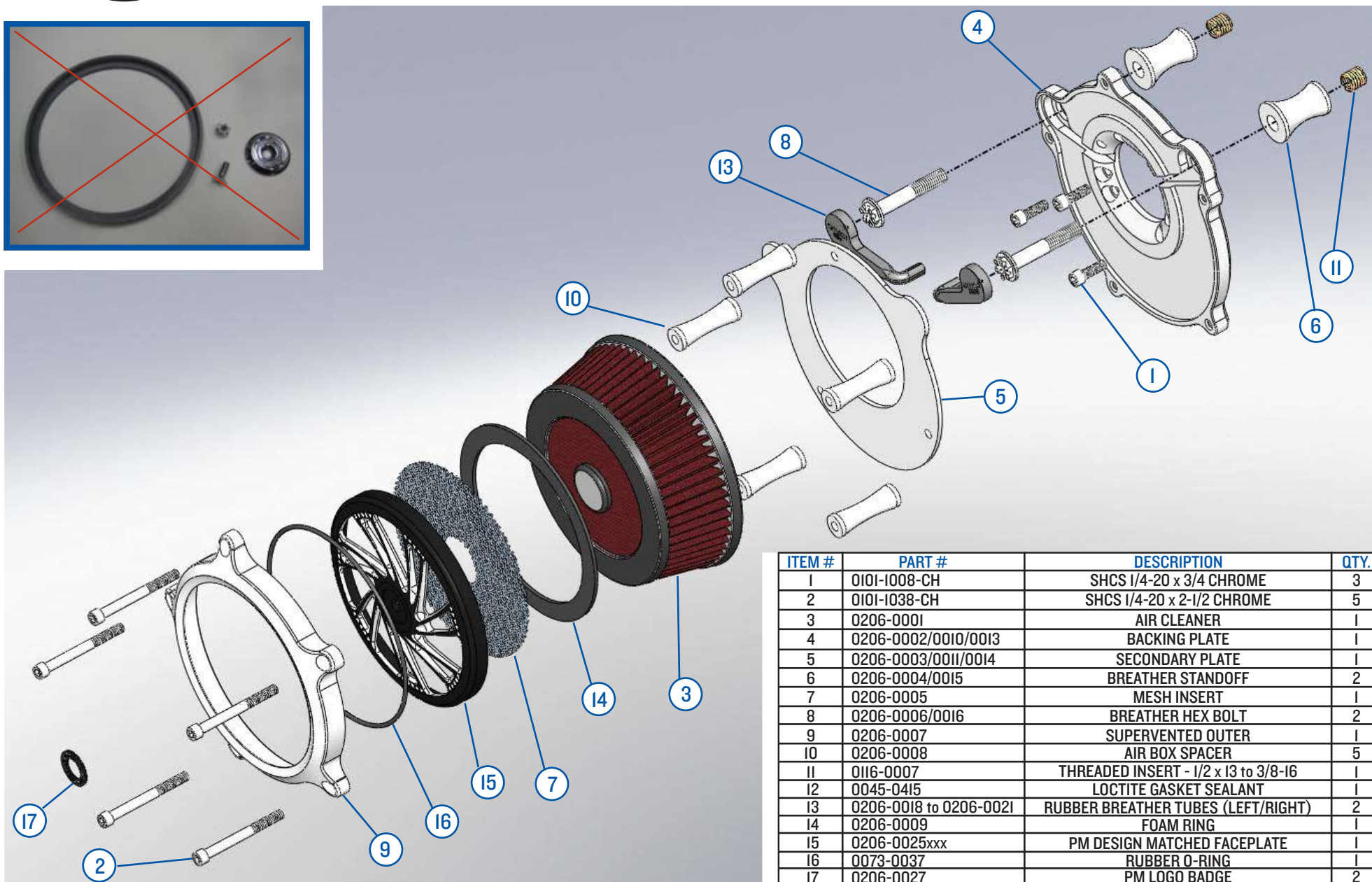

ITEM #	PART #	DESCRIPTION	QTY.
1	0101-1008-CH	SHCS 1/4-20 x 3/4 CHROME	3
2	0101-1038-CH	SHCS 1/4-20 x 2-1/2 CHROME	5
3	0206-0001	AIR CLEANER	1
4	0206-0002/0010/0013	BACKING PLATE	1
5	0206-0003/0011/0014	SECONDARY PLATE	1
6	0206-0004/0015	BREATHER STANDOFF	2
7	0206-0005	MESH INSERT	1
8	0206-0006/0016	BREATHER HEX BOLT	2
9	0206-0007	SUPERVENTED OUTER	1
10	0206-0008	AIR BOX SPACER	5
11	0116-0007	THREADED INSERT - 1/2 x 13 to 3/8-16	1
12	0045-0415	LOCTITE GASKET SEALANT	1
13	0206-0018 to 0206-0021	RUBBER BREATHER TUBES (LEFT/RIGHT)	2
14	0206-0009	FOAM RING	1
15	0206-0025xxx	PM DESIGN MATCHED FACEPLATE	1
16	0073-0037	RUBBER O-RING	1
17	0206-0027	PM LOGO BADGE	2