

Parts List

The HDK001X includes everything you will need for proper mounting of an aftermarket radio into the dash of your motorcycle. This kit contains the following parts:

1. Dash Kit

- (x2) Face plates (one is equipped with a splash guard)
- (x2) Mounting Brackets (one left and one right)
- (x4) Stainless steel bolts (short)
- (x4) Stainless steel nuts
- (x2) Spacers (used for Road Glide models only)
- (x4) Stainless steel bolts (long - for use with spacers)

2. Rubber Gasket Ring

3. Wiring harness (pre-wired with power, speaker & SWI-HD specific connector)

4. SWI-HD (pre-programmed with custom Harley firmware- no initial programming necessary)

Required Tools

The following is a list of tools (not included) you will need to complete this installation.

- T-25 Torx driver
- T-27 Torx driver
- 3/16" or 5mm Hex Socket
- 1/4" or 6mm long shaft Hex Socket
- 7/16" Socket/ratchet combo or box wrench (Road Glide models only)

Fairing Disassembly

2006-2013 FLHX Street Glide & 1996-2013 FLHT Electra Glide Models

Removal of the outer fairing and windshield:

FLTR (Road Glide) instructions on next page

1. Drape front fender area with protective material/ pad to prevent scratching or damaging the paint.
2. From the front of the motorcycle, loosen the three T27 TORX screws located (Numbered 1, 2 & 3 on illustration) below the windshield.
3. Raise and remove the windshield from the inner and outer fairings.
4. Remove the two T27 TORX screws located on outer sides of the speakers (Numbered 4 & 5 on illustration).
5. Turn the handlebar to the right and remove the T-27 TORX screw (Number 6) by reaching below the left side of the fairing cap.
6. Turn the handlebar to the left and remove the T-27 TORX screw (Number 7) by reaching in below the right side of the fairing cap.

CAUTION: When working on FLHX models, be sure to hold the outer fairing in place when removing the last screw. Without the auxiliary lamps to hold it in place, the outer fairing will drop and can cause damage to the fairing or fender.

7. From the front of the motorcycle, remove the three screws below the windshield. (Previously loosened in step 2)
8. Tilting the outer fairing forward, remove head lamp connector at the back of the head lamp assembly.
9. Lift the outer fairing off the motorcycle.

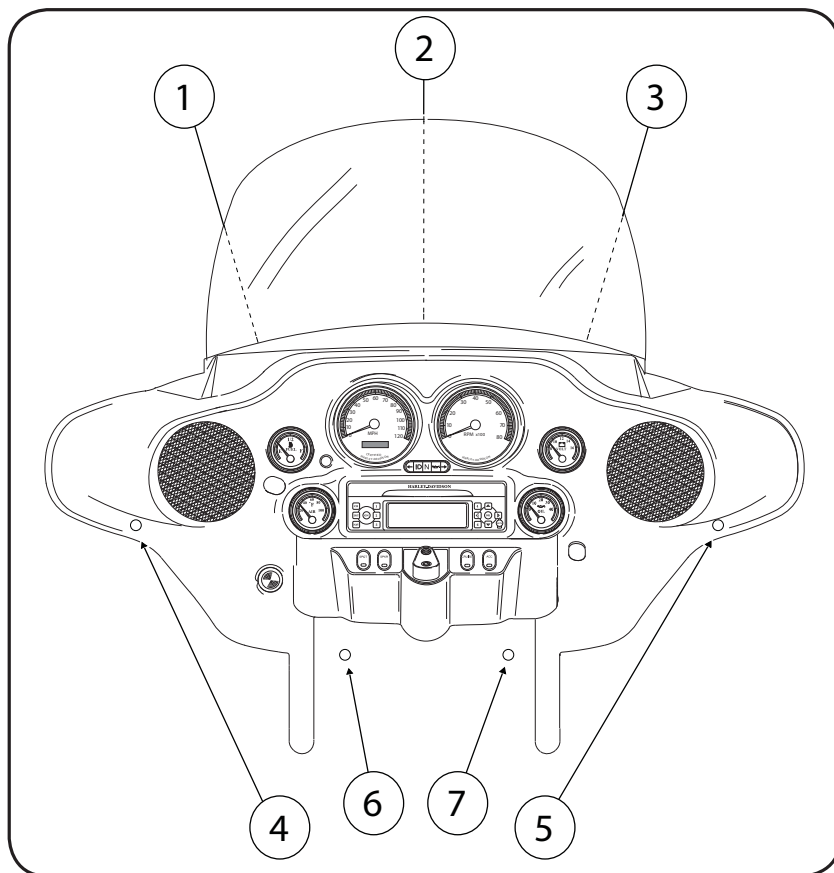

Fairing Disassembly: (cont.)

1998-up FLTR Road Glide Models

Remove the outer fairing and windshield as follows:

NOTE: Windshield may be left in place during outer fairing removal.

1. Drape front fender area with protective material/pad to prevent scratching or damaging the paint.
2. Remove the two T-25 Torx screws located at the outer edge of the fairing next to the left and right speakers (Numbers 3 & 4 of Image A).
3. Loosen the two T-25 Torx screws located at the top left and right corners of the fairing next to the fuel and volt gauges, respectively (Numbers 1 & 2 of Image A).
4. Remove the two T-25 Torx screws just below left and right side glove compartments (Numbers 5 & 6 of Image A).
5. On inboard side of right fairing support, remove the two rear acorn nuts (Image B) from the studs of front turn signals (left and right). Pull front turn signal lamp assembly from the motorcycle and allow it to hang from the front of engine guard.
6. Remove the top left and right screws next to the fuel and volt gauges previously loosened in step #3.
7. Raise outer fairing slightly and then rest on protective fender pad.
8. Squeeze two external tabs to disconnect headlamp jumper harness connector.
9. To avoid possible wire damage, disconnect front turn signal lamp connectors and place in safe area.

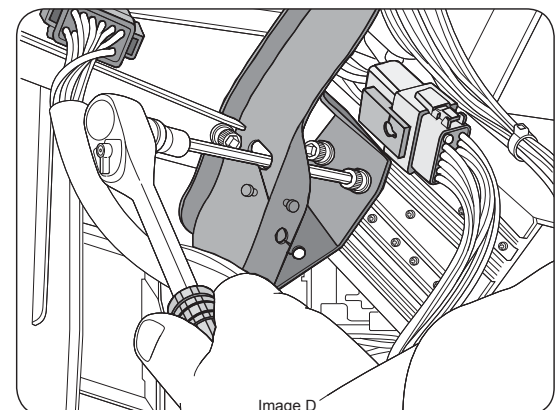
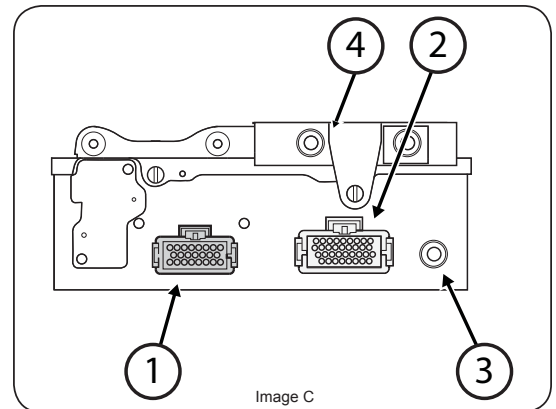
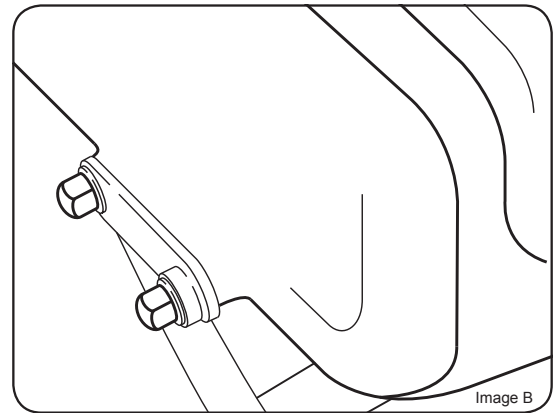
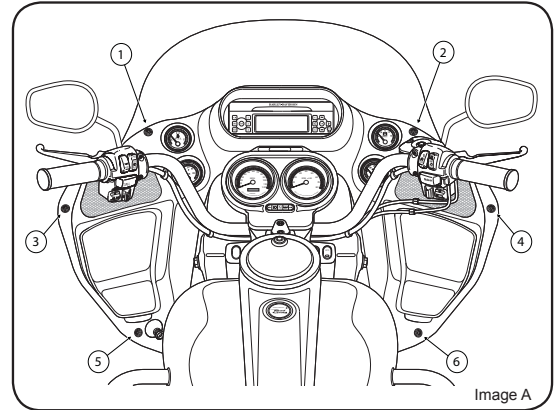

Radio Removal

Remove the radio from the dash cavity as follows:

1. Disconnect and remove the CB module (Number 4 of image C, if equipped) from the factory radio. To do this disconnect the CB antenna and the 12-pin connector from the CB module. Once the connectors have been detached, remove the screw to separate the CB module from the radio.
2. Disconnect the radio connectors behind the radio (See Image C).

NOTE: Not all motorcycles are equipped with connector #2.

3. Using a long shank ball end socket, remove four 6mm hex bolts (two on right, two on left) to release radio or storage (FLHT) from left and right radio support brackets. Use oblong holes on brackets to access screws. (See Image D to the right for reference).
4. Pull radio or storage box (FLHT) forward (towards front) to remove from opening in the inner fairing.

Kit Assembly

1. Decide which main frame (faceplate) to use for installation (with or without the splash guard).
2. Install the side brackets to rear of main frame.
3. Insert the stainless steel nuts (provided) to the side brackets. They are sized to fit snug in the hex openings. *NOTE: Some force may be required to seat them all the way in the openings.*
4. Insert an ISO mountable single DIN radio between the left and right ISO mount brackets and loosely attach to sides of the radio using the screws provided with radio when possible, or use the screws supplied with kit.
5. Using the main frame of the HDK001X as a guide, slide radio forward or backward to desired depth/look and then tighten screws to the radio. If the main frame with splash guard is used for installation, ensure the hinged door opens and shuts properly before tightening of the screws to the radio.
6. Slide the included rubber gasket onto the front edge of the main frame being used.
7. Insert the kit and radio combo into the factory radio opening from the back side of the inner fairing.
8. If the kit does not fit snug between the radio mounting brackets then the optional spacers (included) may need to be used.
9. Secure the kit and radio combo using the supplied hardware (use the short screws, or longer screws if spacers were used).

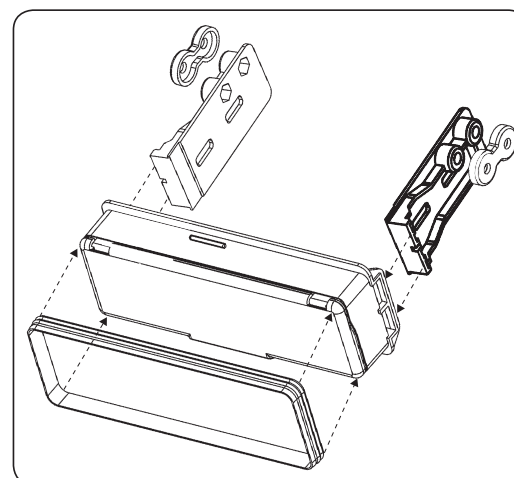
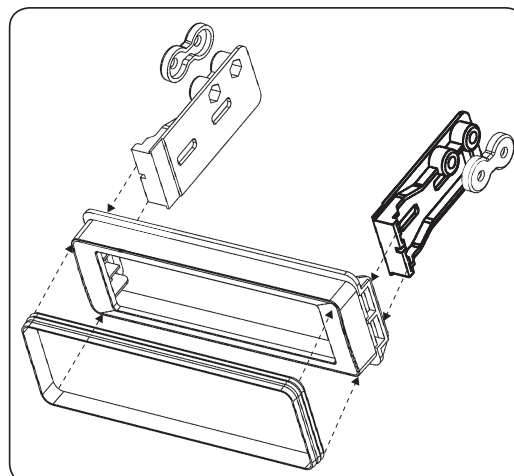

Harness & Module Overview

Vehicle Connector

Wire Color	Function
Yellow	Constant +12v
Red	Accessory
Black	Ground
White	Left Front Speaker +
White/Black	Left Front Speaker -
Grey	Right Front Speaker +
Grey/Black	Right Front Speaker -

SWI-HD Module

Wire Color	Function
Blue/Yellow	Kenwood, Newer JVC or OEM
3.5mm Jack	Advent, Alpine, Boyo, Clarion, Dual, Fusion, JVC, Lightning Audio, Pioneer, Sony, Valor and Visteon

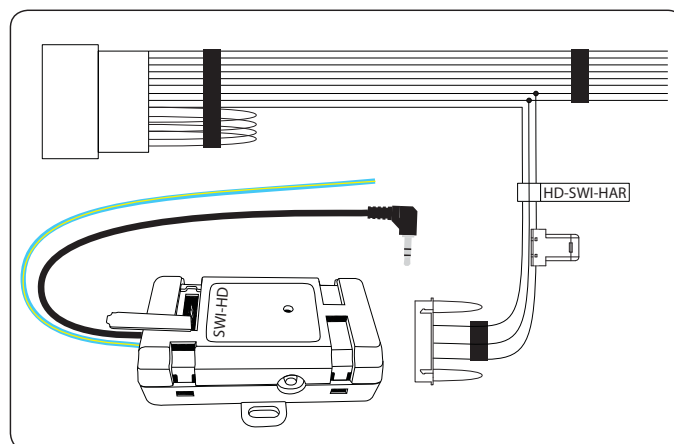

Harness & SWI-HD Installation Steps



SET RADIO SELECT SWITCH

Alpine	JVC	Kenwood	Clarion/Nakamichi	Valor	OEM	Pioneer/Other	Sony	Fusion
1	2	3	4	5	6	7	8	9

Other = Advent, BOYO, Dual, Lightning Audio, Visteon,

1. The radio select rotary switch on the side of the SWI-HD must be set to the proper radio setting before plugging the interface into the vehicle.
2. Make all connections as described in the chart on page 3.
3. Connect the SWI-HD wire according to the chart on page 3 (aftermarket radio MUST support a wired remote input).
4. If you wish to reassign functions to the handlebar controls, follow the programming instructions in the optional programming section.

Default Handlebar Control Programming

IMPORTANT! The interface comes pre-programmed for the functions listed in the chart below and does not require programming unless you wish to re-assign the handlebar control functions. The SWI-HD can always be restored to default settings by pressing the program button on the side of the interface once and waiting 7 seconds for the module to time out.

Default Handlebar Control Button Assignments

	Alpine	JVC	Kenwood	Clarion	Valor	OEM	Pioneer	Sony	Fusion
Volume +	Volume +	Volume +	Volume +	Volume +	Volume +	Volume +	Volume +	Volume +	Volume +
Volume -	Volume -	Volume -	Volume -	Volume -	Volume -	Volume -	Volume -	Volume -	Volume -
Audio	Mute	Mute	ATT	Mute	Mute	Mute	Mute	Mute	Mute
SQ +	Preset Up	Band/Disc Up	Disc Up	n/a	Up Cursor	Up Cursor	Preset Up	Preset Up	n/a
SQ -	Preset Down	Preset/Disc Down	Disc Down	n/a	Down Cursor	Down Cursor	Preset Down	Preset Down	n/a
Mode	Source	Source	Source	Source	Source	Source	Source	Source	Source
Track +	Track Up	Track Up	Track Up	Track Up	Track Up	Next	Track Up	Track Up	Track Up
Track -	Track Down	Track Down	Track Down	Track Down	Track Down	Previous	Track Down	Track Down	Track Down
PTT	Receive	Phone Receive	Off Hook	Send_End	OK	BT Answer	Answer Call	Answer Call	Audio

Optional Handlebar Control Programming

If you wish to re-assign the handlebar control functions the interface must be programmed in the specific order shown in the chart below. If you come across a function in the chart that your steering wheel does not have, or you do not want to program, press and release the program button on the side of the interface to skip that function. The LED will flash off and on confirming that you have successfully skipped that function and are ready to proceed to the next one.

1. Turn the key to the ignition position.
2. Press and release the programming button on the side of the interface to enter the programming mode.
3. With the LED on, press the first button to be learned on the handlebars, the LED will turn off. Continue to hold the button for up to 5 seconds. Once released the LED will turn back on.
4. If you need to program more buttons, repeat step 3 for each additional audio function on the steering wheel.
5. If you come across a function in the chart that your steering wheel does not have, or you do not want to program, press and release the program button on the side of the interface to skip that function.
6. Once programming is completed, wait seven seconds. The LED will flash three times indicating end of programming.
7. Test the interface for proper functionality. Whenever a handlebar control is pressed the LED on the interface should blink. If any function does not work, repeat the programming steps

Optional Programming Order

	Alpine	JVC	Kenwood	Clarion	Valor	OEM	Other ■	Pioneer	Sony	Fusion
1	Volume +	Volume +	Volume +	Volume +	Volume +	Volume +	Volume +	Volume +	Volume +	Volume +
2	Volume -	Volume -	Volume -	Volume -	Volume -	Volume -	Volume -	Volume -	Volume -	Volume -
3	Mute	Mute	ATT	Mute	Mute	Mute	Mute	Mute	Mute	Mute
4	Preset +	Band/Disc +	Disc +	N/A	Up Cursor	Up Cursor	Preset +	Preset +	Preset +	N/A
5	Preset -	Preset/Disc -	Disc -	N/A	Down Cursor	Down Cursor	Preset -	Preset -	Preset -	N/A
6	Source	Source	Source	Source	Source	Source	Source	Source	Source	Source
7	Track +	Track +	Track +	Track +	Track +	Next	Track +	Track +	Track +	Track +
8	Track -	Track -	Track -	Track -	Track -	Previous	Track -	Track -	Track -	Track -
9	Receive	Phone Receive	Off Hook	Send/End	OK	BT Answer	Answer ■	Answer Call	Answer Call	Audio
10	End	Phone Reject	On Hook	Send		BT Hang Up	END ■	End Call	End Call	Power
11	VR	Select	Tel	End		Play	PTT ■	VR		
12	Power	ATT	Voice	Band		Band		Phone Status/Menu		
13	Enter/Play	Voice Dial	Play/Pause				Band	Band		
14	Band/Program	Power	Mute							

■ - Advent, Boyo, Dual, Lightning Audio, Jensen, Rockford Fosgate & Visteon ■ - Jensen & Advent ONLY

