

Kit Contents

Description	Part No	Pcs
Shock absorber	HD 159	2
Washer 12.8/24/6	03118-08	4
Sleeve 12.7/14/19.5	00123-17	4
Tool preload adjuster	03199-01	1
Sticker "Memo notes"	01180-01	1
Sticker set "ÖHLINS"	10207-01	1
Owners manual	07241-02	1

Note!

These mounting instructions are for the below versions of HD 159

Product Number	Fitted Spring
HD 159	66420-026 (B)
HD 159 S2	66420-028 (B)
HD 159 S3	66420-030 (B)

Note!

Please note that this image is a general representation of the product and may differ slightly from your product.

Note!

Please note that during storage and transportation, especially at high ambient temperature, some of the oil and grease used for assembling may leak and stain the packaging. This is in no way detrimental to the product, wipe off the excessive oil/grease with a cloth.

Note!

Before installing this product, check the contents of the kit. If anything is missing, please contact an Öhlins dealer.

Warning!

Before installing this product, read the Öhlins Owner's Manual. The shock absorber/front fork/steering damper is an important part of your vehicle and will affect the stability.

Shock absorber for Harley Davidson FLH / FLT Models

HD 159 /S2 /S3

Mounting Instructions

MOUNTING INSTRUCTIONS

Warning!

It is advisable to have an Öhlins dealer install the shock absorber/front fork/steering damper.

Warning!

If working on a raised vehicle, ensure it is securely supported so that it will not tip.

Note!

Before mounting this product clean the vehicle thoroughly.

Note!

When working on this product, always see the Vehicle Service Manual for vehicle specific procedures and important data.

1.Put the motorcycle on a lift stand so that the rear wheel barely touches the ground.

2.Loosen and remove the original shock absorber

3.Install the Öhlins shock absorber in the same way as the original shock absorbers with the Nitrogen Fill Screw pointing towards the rear.

Lower the vehicle so that the suspension is slightly compressed before tightening the screws.

Caution!

Ensure that all screws are tightened to the correct torque and that nothing fouls or restricts movement of the shock absorber/front fork/steering damper when the suspension is fully compressed or extended.

MOUNTING INSTRUCTIONS

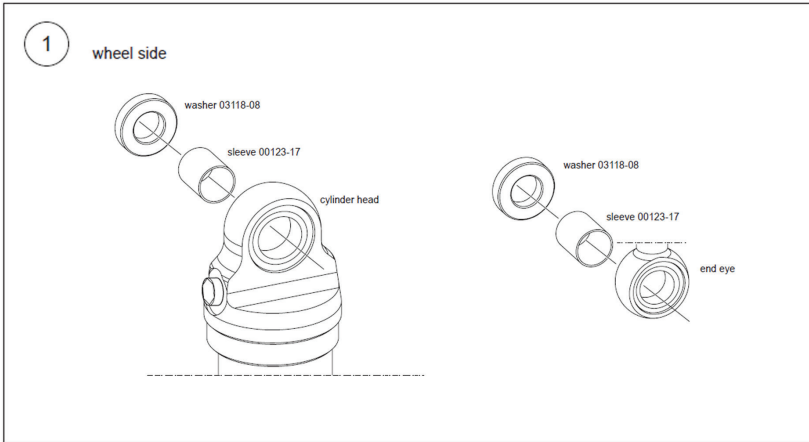

ADJUSTMENTS

⚠ Warning!

Before riding, always make sure that the basic settings made by Öhlins are according to recommended Set-up Data. Read about adjustments and setting up in the Öhlins Owner's Manual before you make any adjustments. Contact an Öhlins dealer if you have any questions about setting up.

SETUP DATA

Recommended set-up

Visit www.ohlinsusa.com / search HD 159 for Spring Preload Calculator

Rebound adjuster 20 Clicks.

Shock absorber data

Length $329^{+5}/_{-5}$ mm.

Stroke 77 mm.

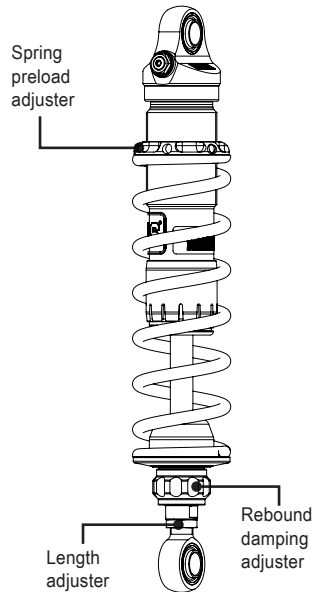

SETUP SPRING CALCULATOR

Go to "www.ohlinsusa.com", under "Product Search", type HD 159 .Once on landing page, select "Setup Calculator"

HD 159 Harley S36 Twin Shocks

OVERVIEW	IMAGES	TECH	SETUP CALCULATOR	SERVICE
----------	--------	------	------------------	---------

**Once you get to the spring calculator, enter all the details about your bike and your weights.*

Note!

- You have the option to change from lbs to kgs.

SETUP CALCULATOR

About Your Bike

Model / Year	1990 - 2020 Harley-Davidson Ultra Class ▼
Tour Pack	<input type="checkbox"/> YES <input checked="" type="checkbox"/> NO
Primary Use	Solo no luggage ▼

About The Rider

[lbs](#) | [kgs](#)

Rider Weight (including gear)	<input type="text"/>	lbs
Passenger Weight (including gear)	0	lbs
Weight in Saddlebags	0	lbs

[New Setup](#) | [Returning Setup](#)

- Once you have entered the correct weights, choose "Returning Setup" so it gives you an option to select the springs installed on your shocks.

SETUP SPRING CALCULATOR

Note!

*Make sure to double check the springs installed on your shocks as the distributor may have changed to accommodate your weight scenarios

Best Fit ▾

Best Fit

66420-026 (26 N/mm)

66420-028 (28 N/mm)

66420-030 (30 N/mm)

00280-21 (25 N/mm) Legacy





00180-97 (27 N/mm) Legacy

00180-22 (29 N/mm) Legacy

21180-01 (32 N/mm) Legacy

6. Once you click "Calculate", the setup data will be displayed. Example below:

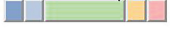
CALCULATE

Rider Scenario	Spring Position	Comfort		SETUP DETAILS
		Soft	Firm	
Solo	26 (mm)			SETUP DETAILS
Solo With Luggage	26 (mm)			SETUP DETAILS
Two Up	26 (mm)			SETUP DETAILS
Two Up With Luggage	26 (mm)			SETUP DETAILS

7. The "Spring Position" will tell you in millimeter the distance the preload collar should be from the bottom of the cylinder head for each scenario with your primary use highlighted in Gold.

You can click "Setup Details" for an image describing further. There's "Setup Details" beside all (4) rider scenarios (Solo, Solo with Luggage, Two Up and Two Up with Luggage) Make sure to click the one you plan to set the bike up for.

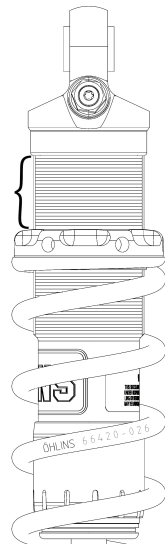

SPRING POSITION

REBOUND ADJUSTMENT

Starting rebound clicker position is 20 clicks out from closed

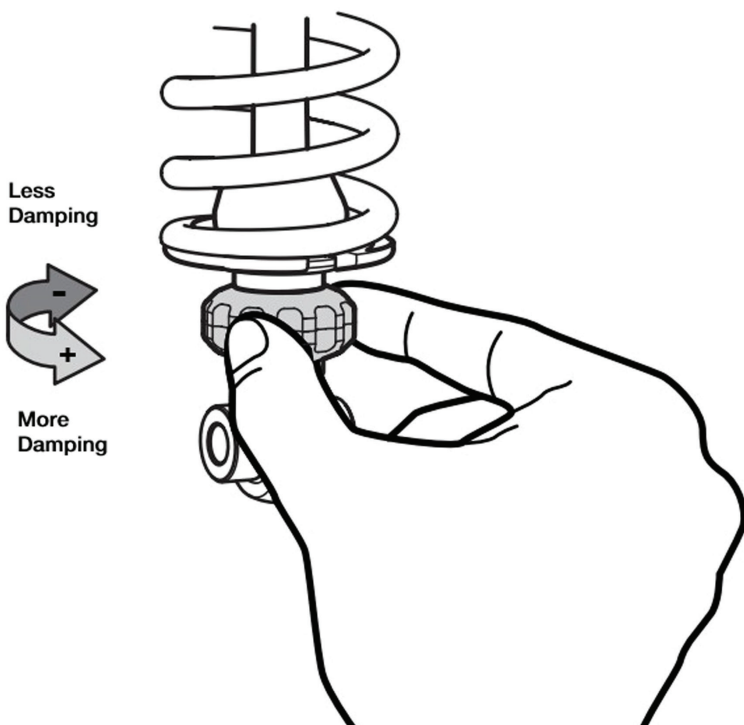

To check it's set correctly, turn in clockwise in the direction of + arrow until it stops, then open 20 clicks. This should be your starting position for rebound. If you want more damping / slower movement, close the rebound in the + direction. If you want less damping / more movement, open the rebound in the - direction.

Note!

Best operating range is 14 – 26 clicks out.

LENGTH ADJUSTMENT

Length adjustment:

By adjusting the length of the shock absorber the steering geometry as well as the chain force can be changed.

A shorter shock absorber will result in a lower motorcycle. The fork angle as well as the trail will increase and normally the chain force will be reduced with less anti-squat as a result.

A slight change of center of gravity is another result of changing the length.

A longer shock absorber will result in a higher motorcycle. The fork angle and trail will decrease and normally the chain force will increase with more anti-squat as a result.

To Adjust Length: We recommend to remove the shock absorber from the vehicle before adjusting the length. Use two 19 or 24 mm wrenches. Hold the upper nut with one hand and at the same time loosen the lock nut (lower nut). Turn the end eye / bracket to the desired length. Please make sure to measure the ride height before and after adjusting the length.

Tightening torque: 19mm wrench 30Nm

Tightening torque: 24mm wrench 40Nm

⚠ Warning!

Remember to lock the lock nut after adjusting the length.

👁 Note!

After adjusting the length, check the head light angle of your vehicle.

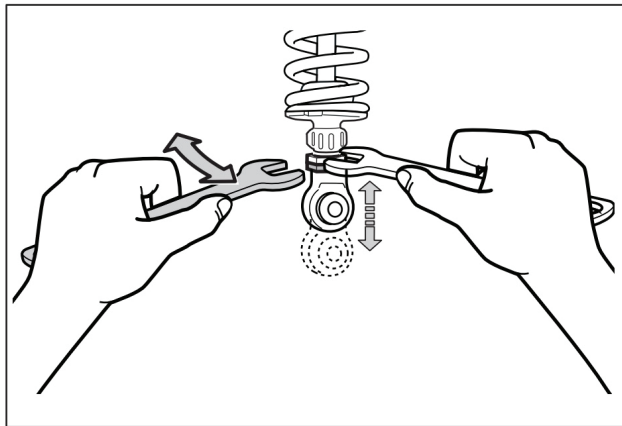
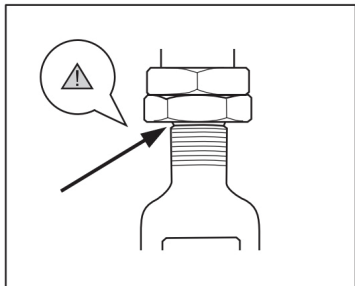

⚠ Warning!

The adjustable end eye/bracket must not be threaded out more than that the groove is fully visible beneath the lock nut. This is maximum length. After adjusting, make sure that the lock nut is tightened.