

Please read instructions carefully before installation. We recommend this product be installed by a qualified, and experienced motorcycle technician. If you are unsure of any of the below directions and or your ability to correctly and securely install this product, please contact us or your local dealer for help. Below diagrams show typical installation, your motorcycle may be different so please use diagrams as a guide. Make sure your motorcycle is clean and free from dirt, road grime etc. where the Nelson-Rigg® luggage mounts. It is the riders responsibility to make sure the product is mounted and secure before each use. Loading the bag may result in a change of position, always check for proper mounting position after loading and before each and every ride.

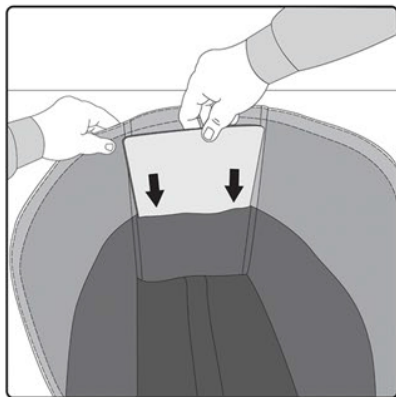

Insert the 2 rectangle plastic stiffeners into each end of the bag.

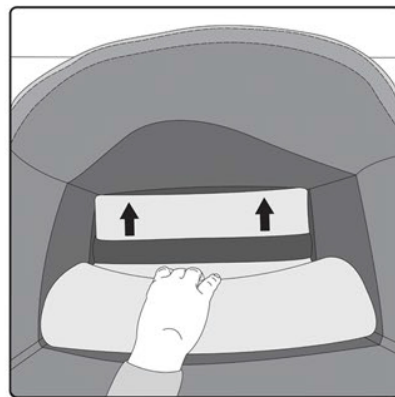

Take the large plastic stiffener and insert it under the loop at the bottom of the bag. Sometimes rolling the stiffener make it easier to insert smoothly.

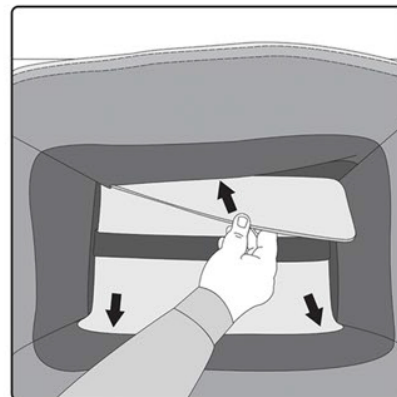

Once in place, insert the ends under the flap as shown. This will hold the stiffener in place.

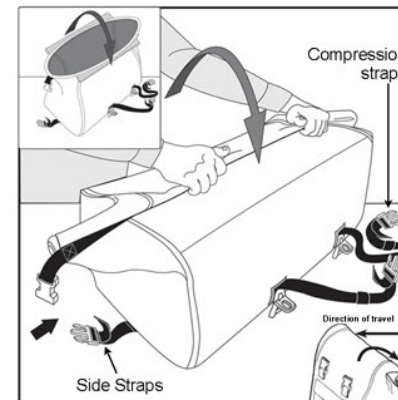

Pack heavier contents at bottom for better weight distribution & balance. Close the top opening while pushing out as much air as possible. Roll the closed end a minimum of 3 times. The less contents the more you can roll. Once tight, connect the male and female buckles on each side and pull tight. Then secure the 2 top compression straps which also double as carry handles. These straps are also removable. While closing, when possible roll opening away from direction of travel so as to not trap air inside folds.

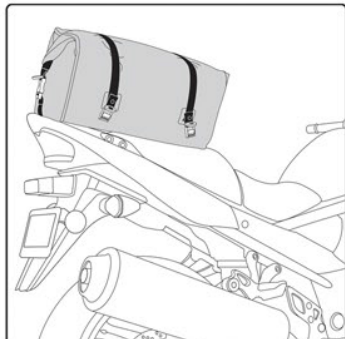

Position tail bag on seat or tail section of the motorcycle making sure bag is centered and free from all moving and hot parts. The bag can be mounted lengthways (front to back) along passenger seat as shown above or across (left to right).

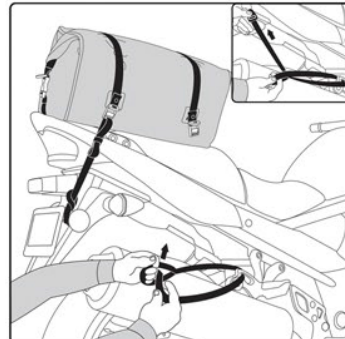

To secure, use the 4 supplied straps with a loop on one side and hook the loop around foot-peg or similar solid bike part or pass the loop around a part of the frame or similar bike part, then push the opposite slanted end through the loop creating a noose securing to your motorcycle. Pull strap to

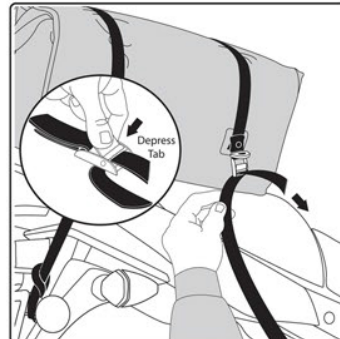

To attach to the cam buckle, depress metal tab and pass the slanted end of the strap through the back of the buckle and out the front as shown in the above illustration.

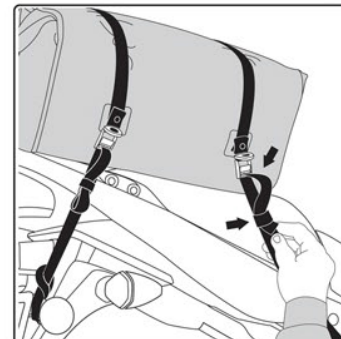

Pull the strap snug ensuring that the bag is resting on a flat surface and has VERY little or no movement. Any extra strap can be folded and tucked inside the provided elastic webbing loop, as shown in

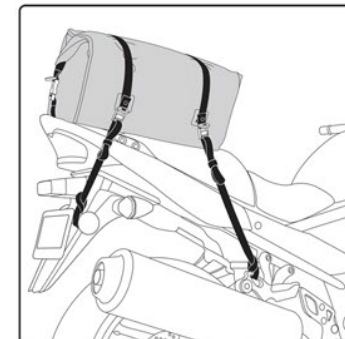

Before operating your motorcycle, double check that the bag and all straps are free from any moving parts or surfaces that may get hot during operation. It's always good practice to recheck all mounting points, stability and condition of the bag and the

### Warning:

Read the installation instructions and make yourself familiar with the process of installing the Nelson-Rigg® product(s) on your bike. It is your responsibility to mount the product correctly and securely as outlined in these instructions. Nelson-Rigg® products are intended for use at USA street legal speeds as posted by the individual States. Nelson-Rigg® luggage must not be overloaded. Max carrying capacity is 10 lbs per bag or the maximum load suggested by the manufacturer of the vehicle, whichever is less. Failure to adhere to these warnings may result in, but not be limited to: the luggage becoming detached, the product becoming tangled in moving parts of the vehicle, unstable vehicle dynamics, reduction in the ability to control the vehicle. The result(s) could lead to serious injury. **Always ride safely, adhering to the local highway regulations. Always wear a helmet and protective apparel.**

