

Instructions NR-300 Traveler

Please read instructions carefully before installation. We recommend this product be installed by a qualified and experienced motorcycle technician. If you are unsure of any of the below directions and/or your ability to correctly and securely install this product, please contact us or your local dealer for help. Below diagrams show typical installation, your motorcycle may be different so please use diagrams as a guide. Make sure your motorcycle is clean and free from dirt, road grime, etc. where the Nelson-Rigg luggage mounts.

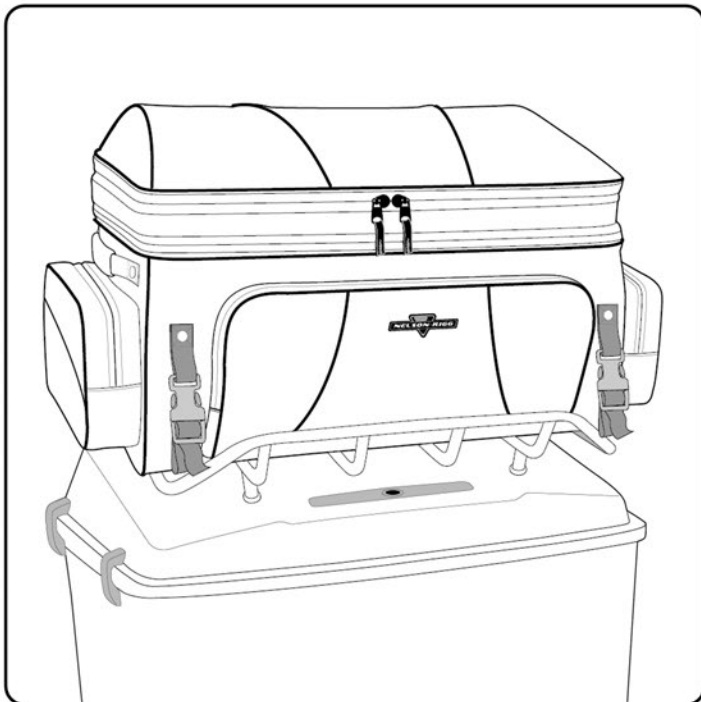

Position bag flat on your luggage rack making sure the bag is centered and free from any moving parts and not obstructing your view while riding. Always store heavier items in the bottom of the bag for better weight distribution and balance.

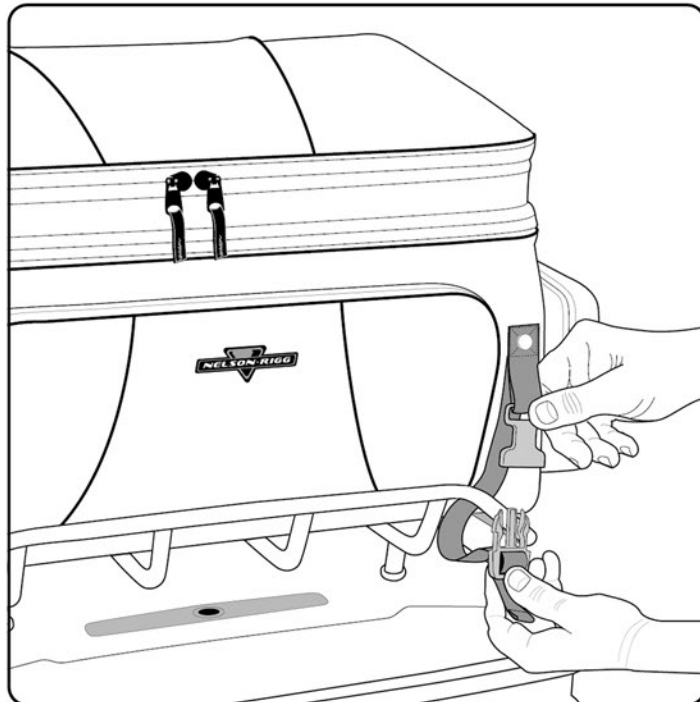

Pass the strap with the male buckle around the luggage rack or post and reconnect back into the female buckle attached to the bag. Make sure the male buckle clicks into place when inserted. Follow on all 4 straps on the bag. Do not tighten.

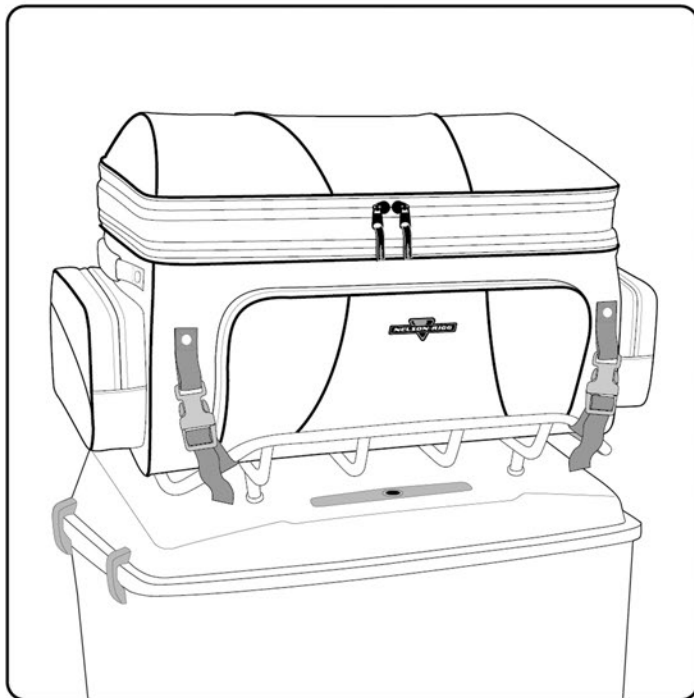

Once all buckles are attached, check the positioning of the bag on the rack to make sure its seated correctly and centered.

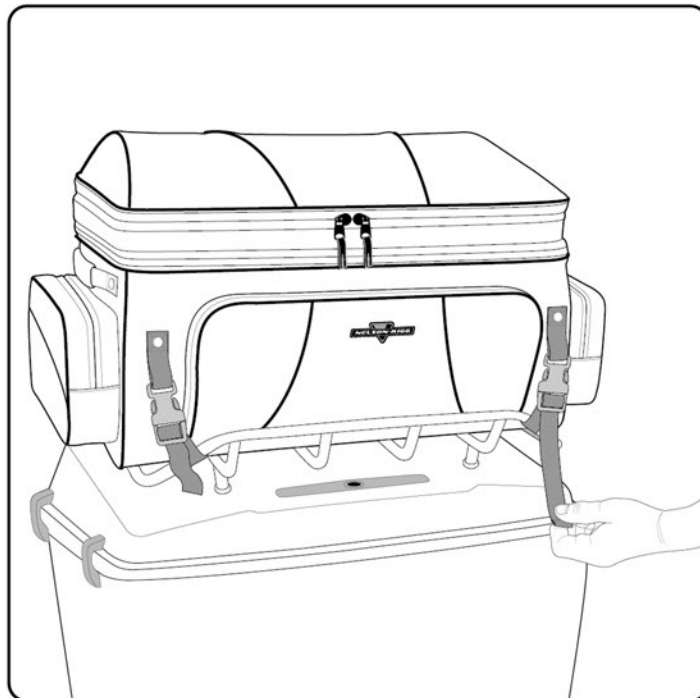

Start to tighten each strap by pulling on the loose webbing until the bag is securely attached to the rack. Each strap has intentionally been left long to accommodate different mounting points on various racks. Any excess webbing can be tucked under the elastic sleeves on the straps, tied off, or cut and sealed at the ends with a lighter. Make sure the bag is secure before riding.

Warning:

Read the installation instructions and make yourself familiar with the process of installing the Nelson-Rigg® product(s) on your bike. It is your responsibility to mount the product correctly and securely as outlined in these instructions. Nelson-Rigg® products are intended for use at USA street legal speeds as posted by the individual States. Nelson-Rigg® luggage must not be overloaded. Max carrying capacity is 10 lbs per bag or the maximum load suggested by the manufacturer of the vehicle, whichever is less. Failure to adhere to these warnings may result in, but not be limited to: the luggage becoming detached, the product becoming tangled in moving parts of the vehicle, unstable vehicle dynamics, reduction in the ability to control the vehicle. The result(s) of could lead to serious injury. Always ride safely, adhering to the local highway regulations. Always wear a helmet and protective apparel.

