



By National Cycle

INSTALLATION AND OWNER'S MANUAL

P9BR204

for Suzuki C90 Boulevard 2005~

Please read and understand these instructions completely before installation to avoid any possible injury to yourself or damage to your motorcycle and/or the accessory.

DEALER: These instructions contain important information for future reference and must be given to the customer.

PARTS LIST				
Item	Part Number	Description	Qty.	Note
1	37-371188-000	Side Plate, Left	1	
2	37-371189-000	Side Plate, Right	1	
3	80-890008-000	Eyebrow, Left	1	
4	80-890009-000	Eyebrow, Right	1	
BAG #879				
5	34-340519-000	Spool, Rear	2	
6	34-340518-000	Spool, Front	2	
7	51-516475-000	Screw, Button M8 x 75	4	
8	34-342807-000	Spacer, Rear	2	
9	34-342806-000	Spacer, Front	2	
10	44-441901-000	Cushion, Urethane	2	
11	42-483020-000	Nut, Hex M8	4	
12	34-340506-010	Cover, Rear	2	

Report any missing parts directly to National Cycle, Inc. There is important code information located on the end panel of box that will be necessary when reporting missing parts.

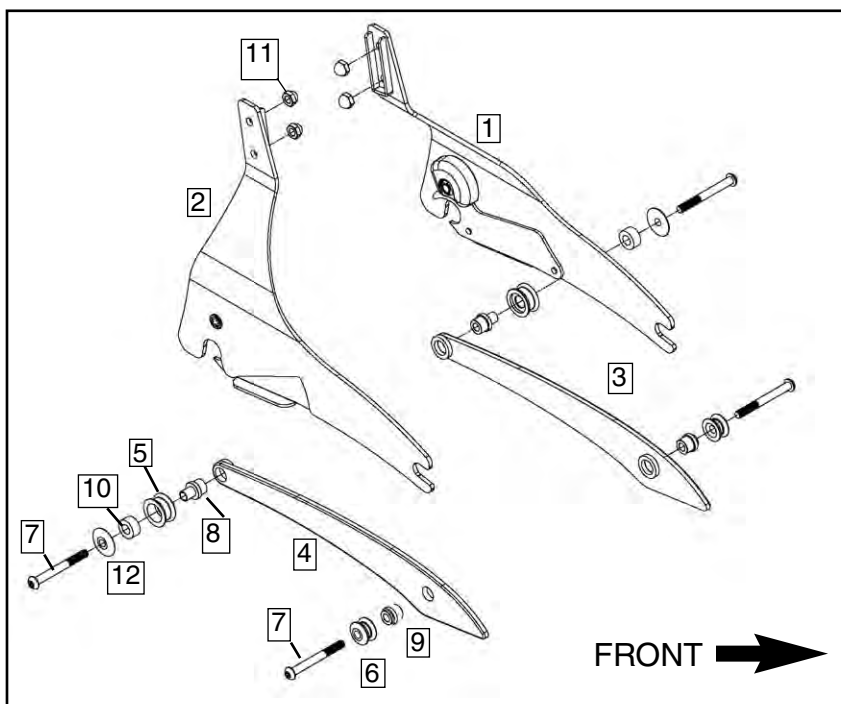

The following symbols are used in these instructions:



Special notes and cautionary measures.



Tips for facilitation of operation, control and adjustment, as well as maintenance work.

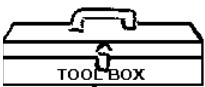

Right and Left side of Motorcycle is determined while sitting on the bike.

Hex Wrench: 5mm (Rear Spool assembly, Front Spool assembly, Backrest/Luggage Rack)

Hex Wrench: 5/32" (Backrest Pad)

Open End or Box Wrench: 13mm (Support Stay)

Torque Wrench: To torque all fasteners

Thread Lock: Loctite® #243 or comparable

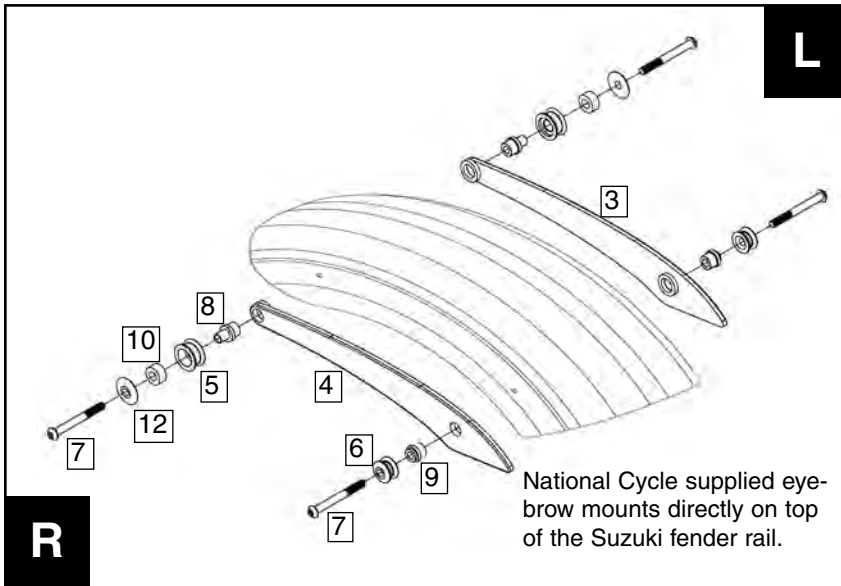

Figure 1

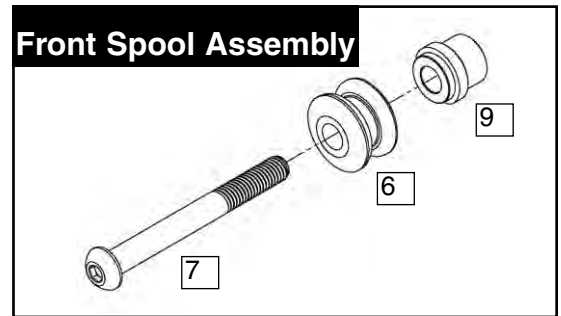
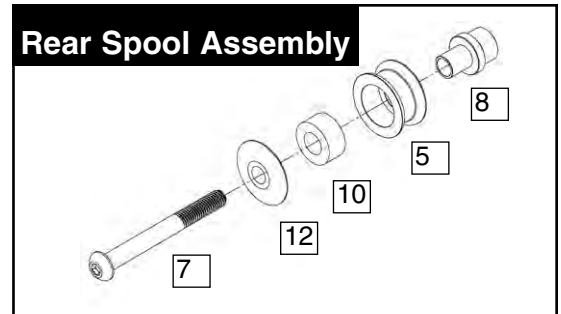

Figure 2

PREPARATION

1. Place motorcycle on flat and level ground with side stand securely in place.
2. Apply a coat of high quality polish or wax to the chrome side plates before assembly. This will keep latches gliding smoothly onto the Spools.
3. Position the motorcycle securely so it cannot fall.

INSTALLATION OF EYEBROW and SPOOLS

1. Start on right side of the motorcycle and remove the front bolt from the fender and trim rail. Stock bolts will not be reused.



National Cycle supplied eyebrow will mount directly on top of the stock fender rail.

2. Assemble Front Spool assembly into the Right Eyebrow (item 4) and through the fender. Do not fully tighten. Repeat for Rear Spool assembly. Do not fully tighten. This will allow some movement, which aids in the Side Plate installation. (5mm Hex Wrench) Figure 1.



After final assembly, torque fender mount fasteners to 22 Nm (17 ft/lb).

3. Repeat steps 1-2 for the left side fender assembly.

ASSEMBLY OF BACKREST AND LUGGAGE RACK COMPONENTS

 The Paladin Backrest and Luggage Rack are sold separately. Backrest part no. P9800A; Rack part no. P9900.

 Before installing fasteners, we recommend you apply a small amount of Loctite® medium strength #243 thread locking compound (or similar brand) to the threads of the Button Head Screws (a) and to the M8 and M10 Screws used to assemble Spools (page 2, step 2). **(Thread Lock)**

1. Assemble Side Plates (1) and (2) to the Paladin Backrest alone or with the Paladin Luggage Rack. **(5mm Hex Wrench) Figure 3**

2. Use the Button Head Screws (a) and the Support Stay (b) provided with the Backrest to complete assembly of the Side Plates. **(5mm Hex Wrench and 13mm Wrench) Figure 3**

3. Install Backrest Pad to Backrest. **(5/32" Hex Wrench)**

3. Torque Screws (a) and Cap Nuts (11) to 22 Nm (17 ft/lbs). **(Torque Wrench)**

INSTALL ASSEMBLY TO MOTORCYCLE

1. Check that the QuickSet lock is unlocked. Install Backrest assembly onto motorcycle by first positioning Side Plates on Front Spools. With smooth continuous forward force, rotate the Backrest assembly downward onto the Rear Spools while pushing down firmly to engage Side Plate latch mechanism with the Rear Spools. **Figure 4**

2. Tighten the four M8 Screws to 22 Nm (17 ft/lbs). **(Torque Wrench)**

3. Make sure to lock the Backrest in place before operating the motorcycle.

4. To remove Backrest assembly, stand behind vehicle. Unlock and pull up gently on Side Plate latch mechanisms. Rotate Backrest assembly upward and then pull back to disengage from Front Spools.

PATENT No. 6484914

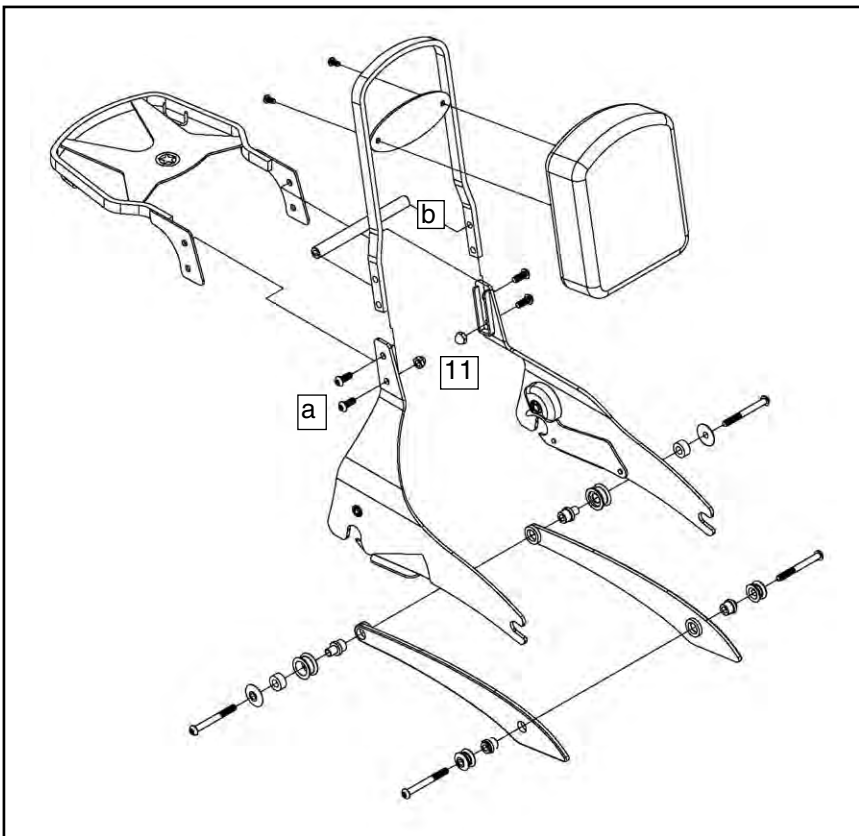

Figure 3

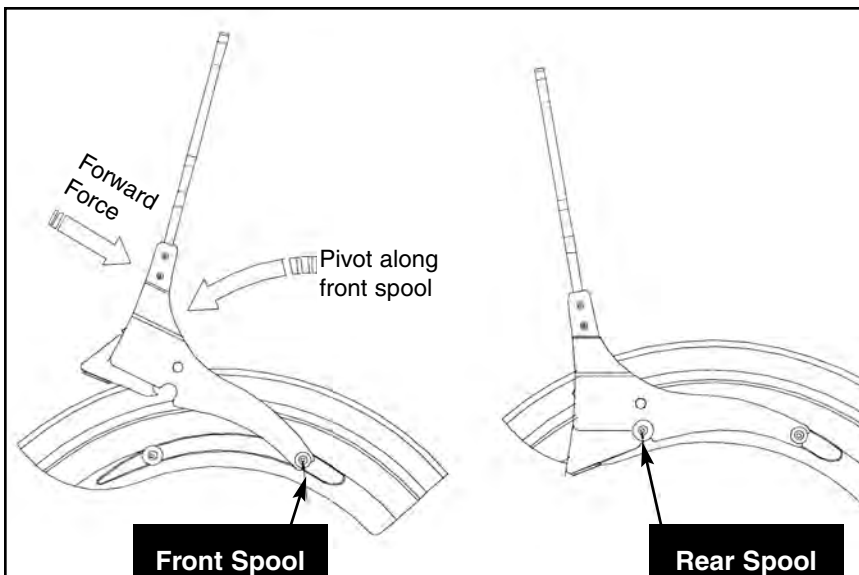

Figure 4

WARNING

Maximum load for the Luggage Rack is 5 Kg (11 lbs).

When mounting the Backrest assembly, listen for the audible "click" indicating that the latches are in place. Always lock the QuickSet Side Mount Plate before using your motorcycle. This insures the utmost in safety.

Never ride your motorcycle with loose accessory mounting hardware. Check the hardware for tightness regularly.

Today's motorcycles are built with enough frame rigidity to withstand the moderate loads imposed on them by the foreseeable addition of an accessory. If the accessory(ies) adversely affects your motorcycle's stability, immediately remove the accessory(ies). Do not ride a motorcycle that exhibits unsafe handling traits.

Have experienced service personnel correct any problem before riding with the accessory(ies) installed. For further questions concerning handling problems associated with an accessory(ies), contact your dealer, motorcycle manufacturer, or accessory manufacturer.

MAINTENANCE

The high quality chrome finish of your National Cycle Paladin Backrest/Luggage Rack assembly can be maintained with any quality chrome cleaner and or polish. Spools can be lubricated periodically with any common household lubricant.