



By National Cycle

# INSTALLATION AND OWNER'S MANUAL

P9BR106

for Kawasaki VN900 B Classic

Please read and understand these instructions completely before installation to avoid any possible injury to yourself or damage to your motorcycle and/or accessory.

**DEALER:** These instructions contain important information for future reference and must be given to the customer.

## PARTS LIST

Item	Part Number	Description	Qty.	Note
1	37-371260-000	Side Plate, Left	1	
2	37-371261-000	Side Plate, Right	1	
3	80-890006-000	Fender Eyebrow, Left	1	Assembled w/ cushion
4	80-890007-000	Fender Eyebrow, Right	1	Assembled w/ cushion
<b>BAG#923</b>				
5	34-340519-000	Spool, Rear	2	
6	34-340518-000	Spool, Front	2	
7	51-516460-000	Screw, M8 x 60	4	
8	34-342806-000	Spacer, Front	2	
9	44-441901-000	Cushion, Urethane	2	
10	34-342807-000	Spacer, Rear	2	
11	34-340506-010	Cover, Rear	2	
12	42-483020-000	Cap Nut, Hex	4	Use in rack assembly

Report any missing parts directly to National Cycle, Inc. There is important code information located on the end panel of box that will be necessary when reporting missing parts.

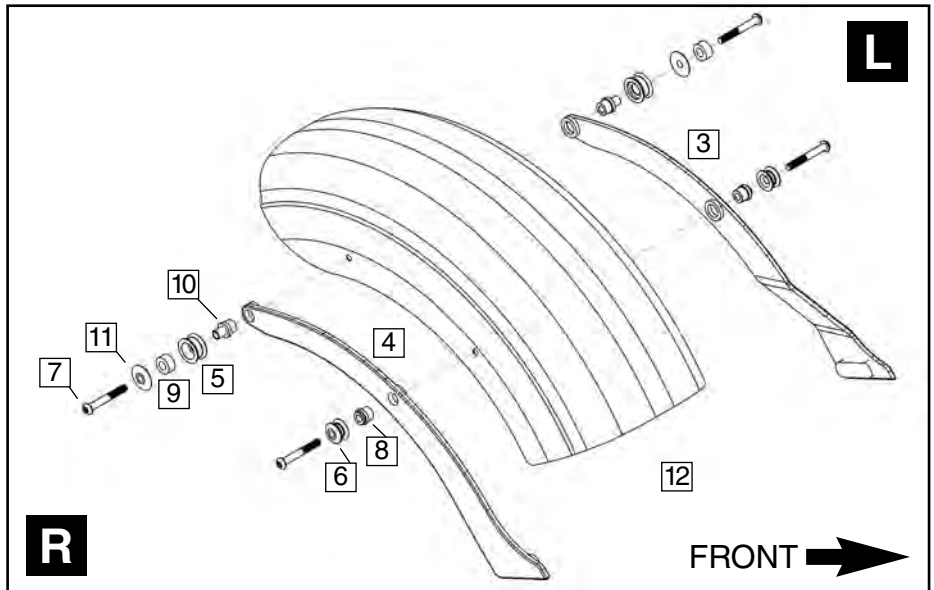
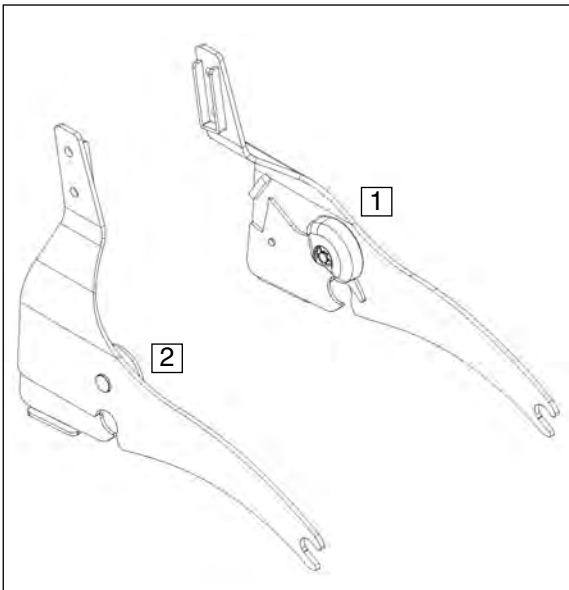

The following symbols are used in these instructions:



Special notes and cautionary measures.



Tips for facilitation of operation, control and adjustment, as well as maintenance work.

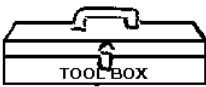

- 5mm Hex Wrench
- Torque Wrench
- Thread Lock, Medium Strength (Loctite® #243 or similar brand)



Right and Left side of Motorcycle is determined while sitting on the bike.

**If Installing Paladin® Backrest/Luggage Rack**

- 13mm Open End/Box Wrench
- 5/32" Hex Wrench

**If Installing Cruiseline™ Saddlebags**

- 6mm Hex Wrench

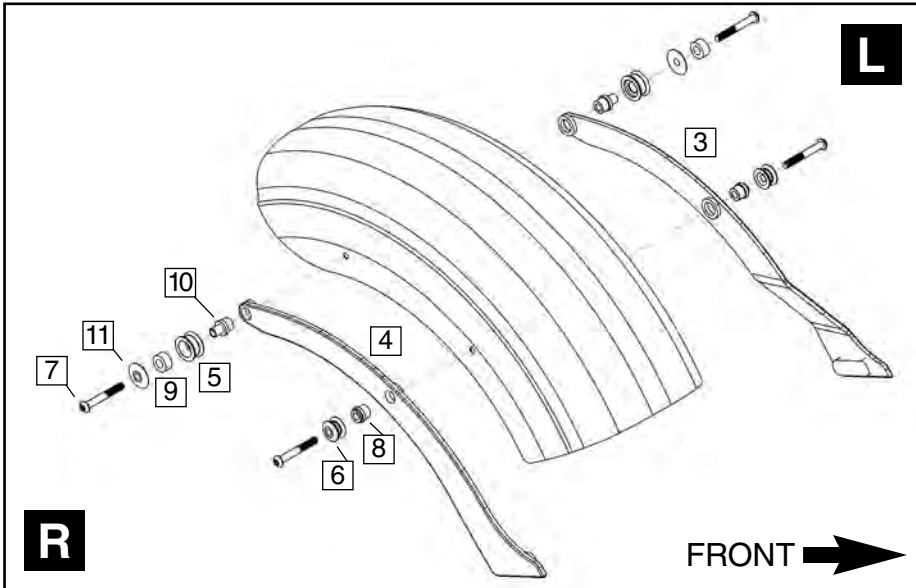

Figure 1

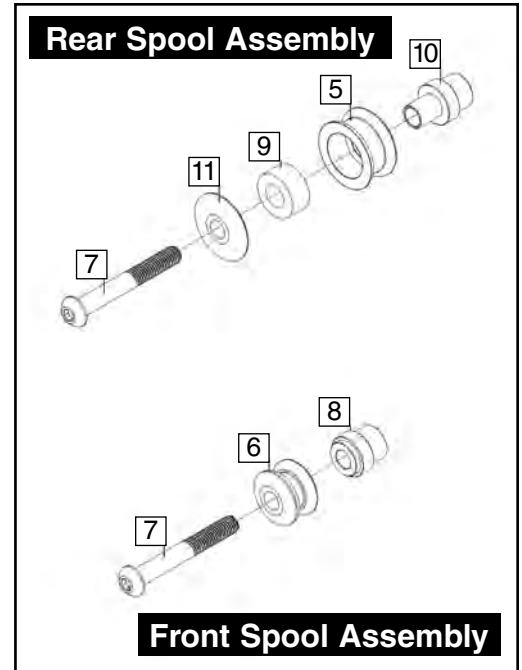

Figure 2

**PREPARATION**

1. Place motorcycle on flat and level ground with side stand securely in place.



Before installing fasteners, we recommend you apply a small amount of Loctite® medium strength #243 thread retaining compound (or similar brand) to the threads of the button head screws (a) referenced on page 3 and to the M8 x 60 fasteners supplied in BAG#923. **(Thread Lock)**

**INSTALLATION OF EYEBROW**

1. Start on right side of the motorcycle and remove the 2 bolts and flange washers holding the OEM outer trim rail from the fender. Remove the trim rail and set aside. Store original bolts, flange washers and trim rails, which will not be re-used. **(5mm Hex Wrench)**

**SPOOL ASSEMBLY, FRONT AND REAR**

2. Continue on the right side by assembling Front and Rear Spool Assemblies and inserting them through the Fender Eyebrow (4) into the threaded holes in the OEM fender struts. Do not fully tighten. This will allow some movement which aids in the final installation of the Paladin Backrest Side Plates on next page. **(5mm Hex Wrench, Thread Lock)**

**Figures 1 and 2**

3. Repeat steps 1-2 for the left side with Front and Rear Spool Assemblies and Fender Eyebrow (3). **(5mm Hex Wrench, Thread Lock)** **Figures 1 and 2**

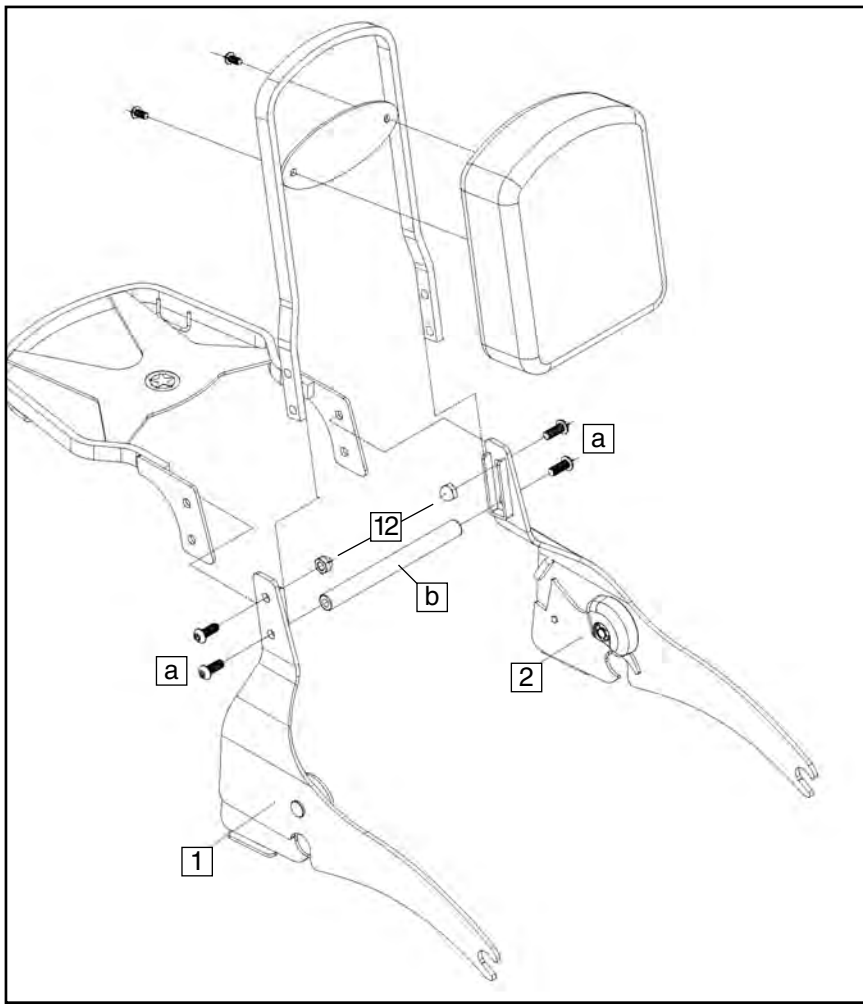

Figure 3

## ASSEMBLY OF COMPONENTS



The Paladin Backrest (part no. P9800A) and Luggage Rack (part no. P9900) are sold separately.



Before installing fasteners, we recommend you apply a small amount of Loctite® medium strength #243 thread retaining compound (or similar brand) to the threads of the Button Head Screws (a) referenced below and to the M8 x 60 Screws used to attach Fender Eyebrows. (page 2, steps 2-3.) **(Thread Lock)**

1. Assemble Side Plates (1) and (2) to the Paladin Backrest, alone or with the Paladin Luggage Rack. **(5mm Hex Wrench, 13mm Wrench, Thread Lock) Figure 3**
2. Use the Button Head Screws (a) and the Support Stay (b) provided with the Backrest Kit to complete assembly of the Side Plates.
3. Torque Button Head Screws (a) and Cap Nuts (12) to 17 ft-lbs (22 Nm). **(Torque Wrench)**

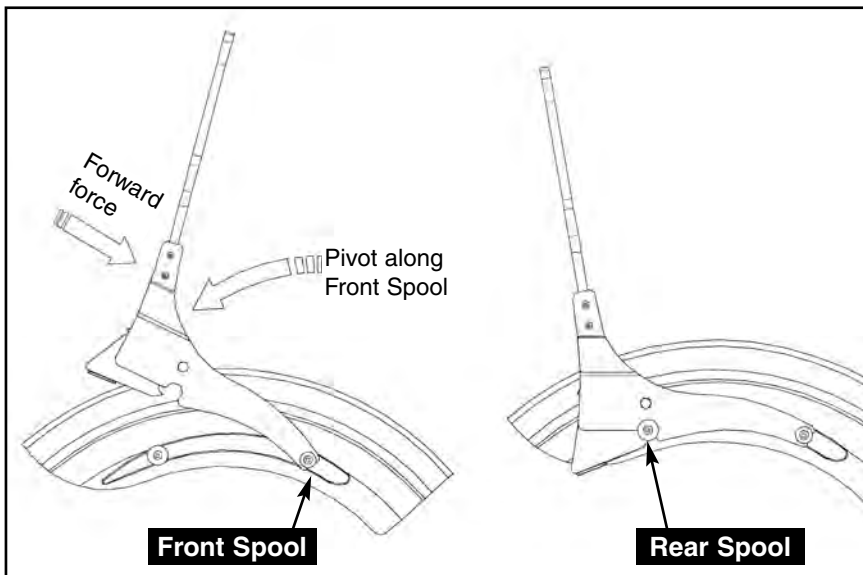

Figure 4

## INSTALL ASSEMBLY TO MOTORCYCLE

7. Check that the QuickSet™ System is unlocked. Install Backrest assembly onto motorcycle by first positioning Side Plates on Front Spools. With smooth continuous forward force, pivot the Backrest assembly downward onto the Rear Spools while pushing down firmly to engage both Side Plate latch mechanisms with the Rear Spools. **Figure 4.**

8. Finally, tighten the four M8 x 60 Screws in the Left and Right Spool Assemblies to 17 ft-lbs (22 Nm). **(Torque Wrench, 5 mm Hex Wrench)**

9. Make sure to lock the Backrest in place before operating the motorcycle.

10. To remove Backrest assembly, stand behind vehicle. Unlock and gently pull up on Side Plate latch mechanisms. Pivot Backrest assembly upward and forward, and then pull back to disengage Backrest assembly from the Front Spools.

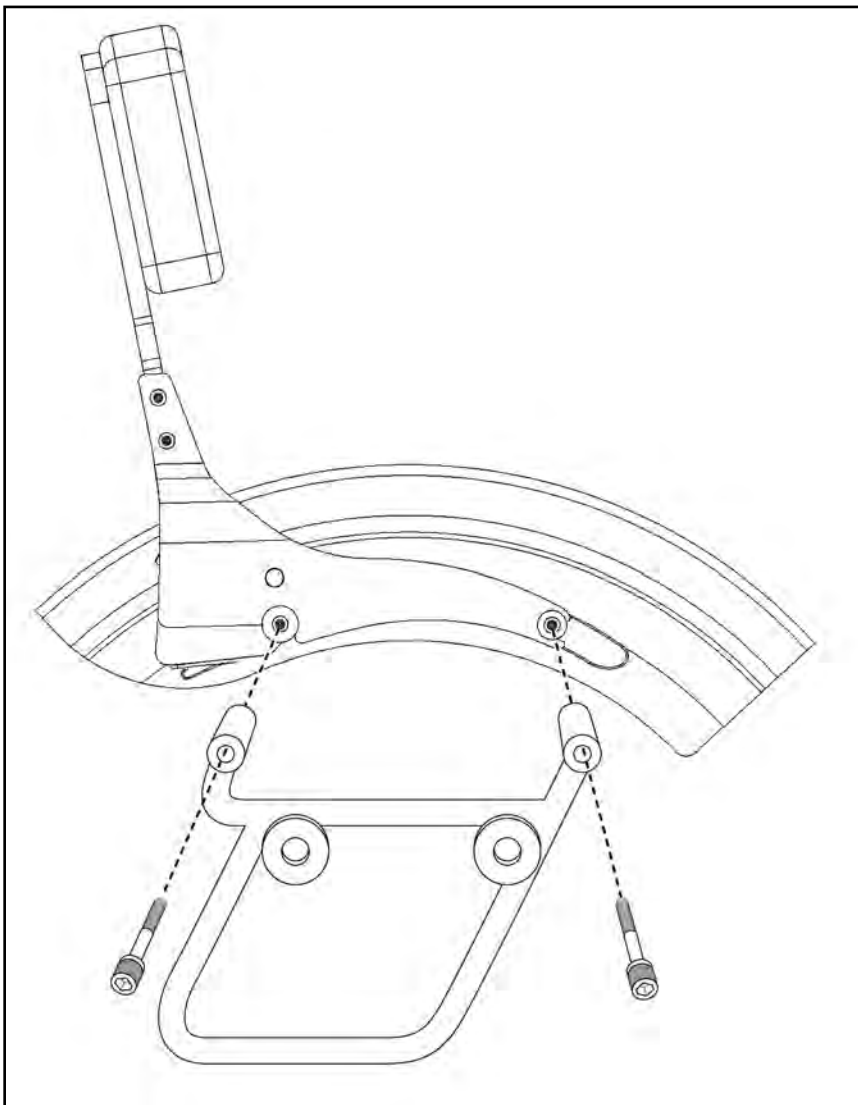

Figure 5

## INSTALLING PALADIN KIT WITH CRUISELINER™ SADDLEBAGS



For this installation, you will need **Cruiseliners Saddlebag Kit and Supplemental BAG#884, which contains four CS/HS M8-1.25 x 75 Stainless Screws. Purchase BAG#884 from your dealer or directly from National Cycle.**



Before installing fasteners, we recommend you apply a small amount of **Loctite® medium strength #234 thread retaining compound (or similar brand)** to the threads of the M8-1.25 x 75 Stainless Screws used to attach the Saddlebag Frame Brackets to the Fender Eyebrows. **(Thread Lock)**

1. Refer to page 1 of this instruction manual and install the Fender Eyebrows and Spool Assemblies as instructed.

### Installing Saddlebag Frame Brackets

2. Remove the M8 x 60 Screw from the *Rear Spool* on one side. Loosely mount rear section of Saddlebag Frame Bracket with an M8-1.25 x 75 Stainless Screw from BAG#884. Repeat this procedure for the Front Spool. **Figure 5**

3. Repeat step 2 installation on other side.

4. Finally, tighten all four M8-1.25 x 75 Stainless Screws to 17 ft-lbs (22 Nm).

## ! WARNING

Maximum load for the Luggage Rack is 5 Kg (11 lbs).

When mounting the Backrest assembly, listen for the audible “click” indicating that the latches are in place. Always lock the QuickSet™ Mount Side Plates before using your motorcycle. This insures the utmost in safety.

Never ride your motorcycle with loose accessory mounting hardware. Check the hardware for tightness regularly.

Today's motorcycles are built with enough frame rigidity to withstand the moderate loads imposed on them by the foreseeable addition of an accessory. If the accessory(ies) adversely affects your motorcycle's stability, immediately remove the accessory(ies). Do not ride a motorcycle that exhibits unsafe handling traits.

Have experienced service personnel correct any problem before riding with the accessory(ies) installed. For further questions concerning handling problems associated with an accessory(ies), contact your dealer, motorcycle manufacturer, or accessory manufacturer.

## MAINTENANCE

The high quality chrome finish of your National Cycle Paladin® Backrest/Luggage Rack assembly can be maintained with any quality chrome cleaner or polish.