



By national cycle

INSTALLATION AND OWNER'S MANUAL
Back Rest P9800A- and Luggage Rack P9900
 for use with appropriate QuickSet 3® Side Plate Mount Kit
 (P9800A and P9900 are sold separately)

INSTRUCTION FOR: PALADIN BACKREST P9800A

PARTS LIST for Back Rest #P9800A

Index	Part No.	Description	Qty.
1	37-371000-000	Upright, Backrest	1
2	70-730075-000	Pad, Backrest	1
3	34-341800-000	Stabilizer Bar	1
BAG #353			
4	51-516023-000	Screw, Button 1/4 20 x 1/2" (with nylok)	2
5	51-516422-000	Screw, Button, M8 x 20 x 1.25P	4



Wrench, 13mm
 Hex Key Wrench, 5/32 or 4mm
 Hex Key Wrench, 5mm

NOTE: Right and Left side of Motorcycle is determined while sitting on the bike.

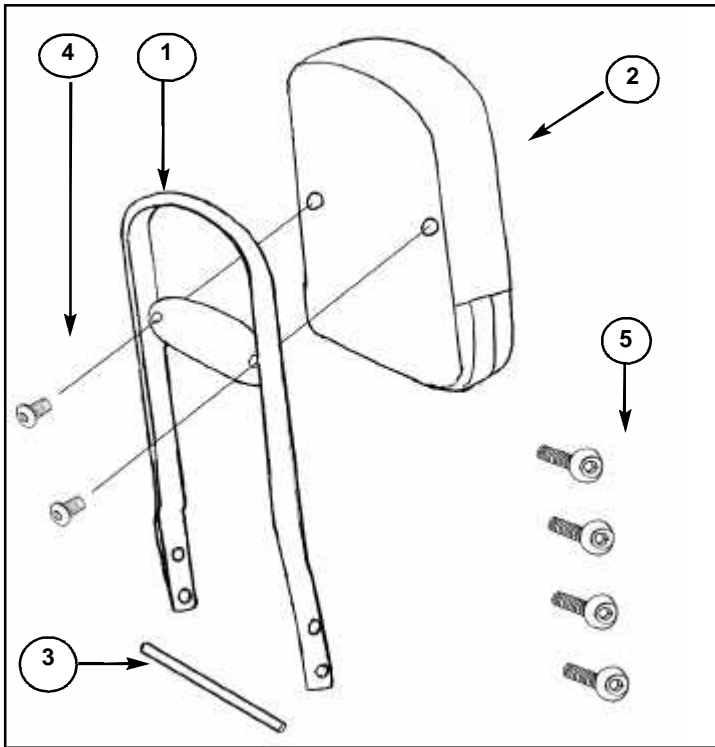

ASSEMBLY OF PALADIN BACKREST P9800A

1. Attach pad to the backrest support at the hole locations in the pad. 1/4 20 x 1/2" screws.

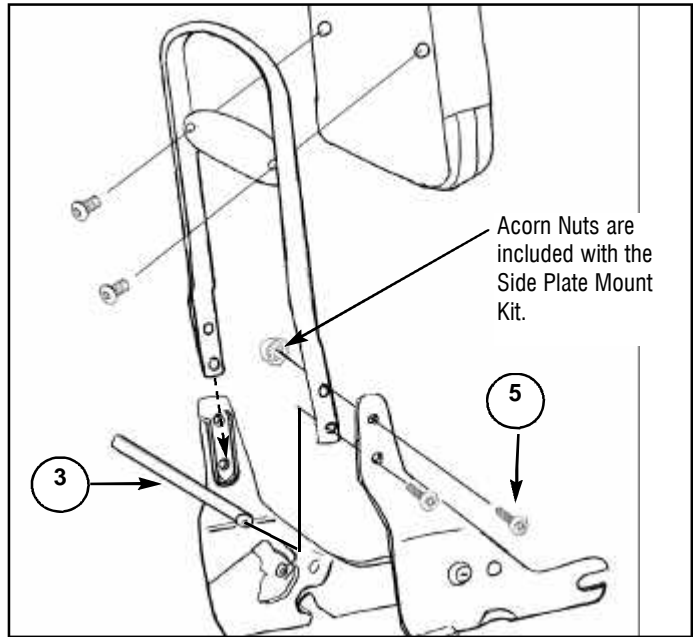

INSTALL BACKREST TO SIDE PLATES.

- Slide backrest support arm into pocket on inside of side plate. Secure at top holes with M8 x 20 x 1.25P screws and acorn nuts. Hold stabilizer bar with threaded ends in place at lower holes. Secure with M8 x 20 x 1.25P screws. Acorn nuts are included with the Side Plate Mount Kit.
- Fully tighten all hardware. M8 x 20 Screws tighten to 13 ft. lbs.

NOTE: If additional fender accessories cause a clearance problem between the Stabilizer Bar and the fender, mount bar at top hole. Check for proper clearance after installation is complete.

INSTRUCTION FOR: PALADIN LUGGAGE RACK P9900

PARTS LIST for Luggage Rack #P9900

Index	Part No.	Description	Qty.
6	37-374100-000	Luggage Rack	1
BAG #355			
7	51-516426-000	Screw, Button M8 x 25 x 1.25P	4
8	51-516416-000	Screw, Button, M8 x 16 x 1.25P	4

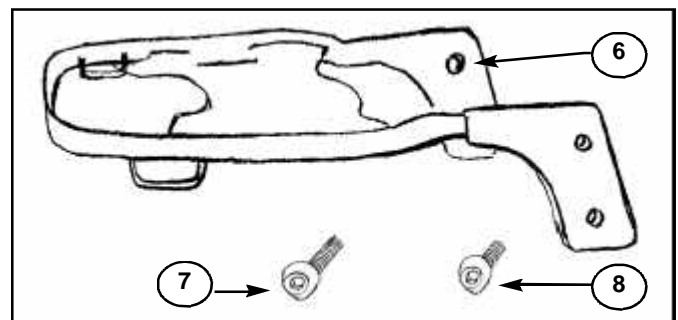

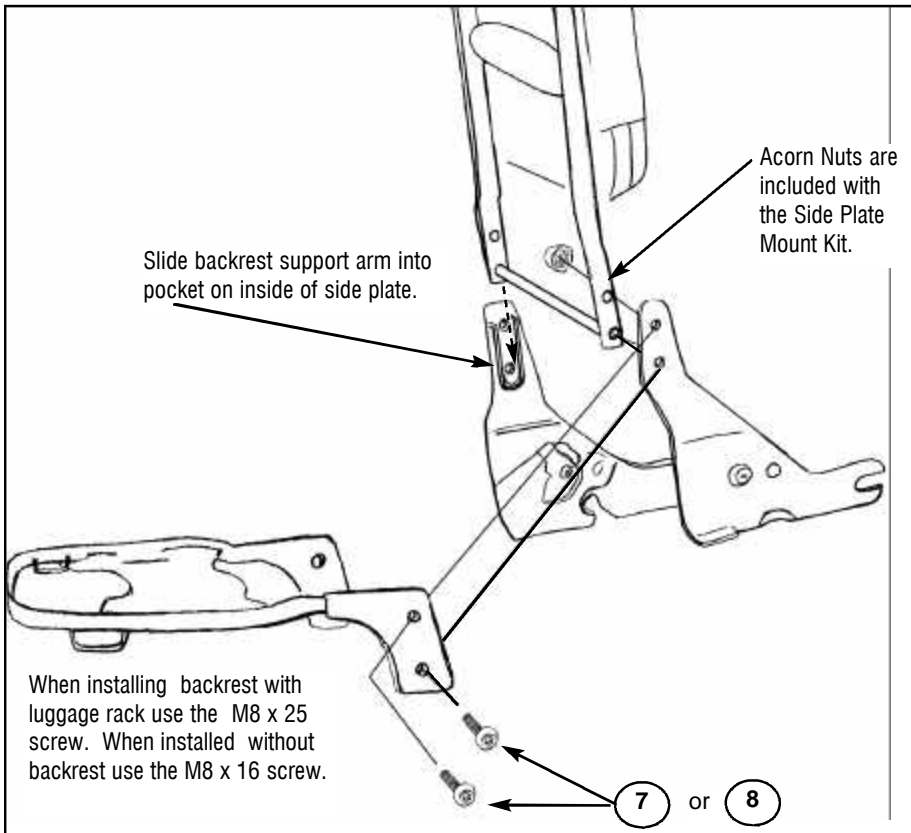

INSTALLATION OF LUGGAGE RACK DIRECTLY TO SIDE PLATES

1. Install luggage rack to outside of side plate. Secure at top holes with **M8 x 16 x 1.25P** screws and acorn nuts. Acorn nuts are included with the appropriate QuickSet 3 Side Plate Mount Kit.

INSTALLATION OF LUGGAGE RACK AND BACKREST TO SIDE PLATES.

1. Slide backrest support arm into pocket on inside of side plate. Place Stabilizer Bar from kit P9800A in place at lower holes. Place luggage rack to outside of side plate and secure the three pieces together with the **M8 x 25 x 1.25P** screws and **acorn nuts** at top holes and the **M8 x 25 x 1.25P** screws directly into the Stabilizer Bar ends at lower holes. Acorn nuts are included with the appropriate QuickSet 3 Side Plate Mount Kit.

2. Fully tighten all hardware to 13 ft lbs.

MAINTENANCE The high quality chrome finish of your National Cycle Paladin assembly can be maintained with any quality chrome cleaner and /or polish.

WARNING

Maximum load for the Luggage Rack is 5 Kg (11 lbs).

When mounting the Backrest assembly, listen for the audible "click" indicating that the latches are in place. Always lock the QuickSet 3® Side Plate Assembly before using your motorcycle. This insures the utmost in safety.

Never ride your motorcycle with loose accessory mounting hardware. Check the hardware for tightness regularly.

Today's motorcycles are built with enough frame rigidity to withstand the moderate loads imposed on them by the foreseeable addition of an accessory(ies). If an accessory(ies) adversely affects your motorcycle's stability, immediately remove the accessory(ies). Do not ride a motorcycle that exhibits unsafe handling traits.

Have experienced service personnel correct any problem before riding with the accessory(ies) installed. For further questions concerning handling problems associated with an accessory(ies), contact your dealer, motorcycle manufacturer, or accessory manufacturer.