

**national cycle**<sup>®</sup>

**since 1937**

## INSTALLATION INSTRUCTIONS AND OWNER'S MANUAL

### P9301 :: BACKREST KIT, YAMAHA XV250, 2006- P9302 :: LUGGAGE RACK KIT, YAMAHA XV250, 2006-

Thank you for purchasing a National Cycle (Paladin) Accessory. Please read these instructions carefully and thoroughly before beginning work. Prior to installing this accessory, carefully consider whether one possesses the necessary technical skills and workshop tools to complete the installation properly. Installation assistance can be found at any motorcycle retailer or dealership. Dealers, if installing this accessory for a customer, please give him or her this manual. This instruction sheet contains the details and reference materials needed to properly maintain and use this product. At the time of purchase, report any missing parts directly to National Cycle. The following information is necessary; BAG NUMBER (located the on outside of plastic fastener bag), as well as the DATE STAMP (located on the end panel of the outer box). Thank you for purchasing this National Cycle product!

#### MAINTENANCE

The high quality chrome finish of your National Cycle Paladin rack assembly can be maintained with any quality chrome cleaner and/or polish. The aplication of cleaners and/or polish should be done with a clean, soft cotton rag or similar.

#### TOOL LIST

Metric Hex Wrench: 5mm, 6mm, 8mm	Box Wrench: 10mm, 12mm, 14mm, .625", 17mm, 19mm
Sockets: 10mm, 12mm, 14mm, .625"	Threadlock: Loctite #262 or comparable
Screwdriver, Phillips: #3	Torque Wrench

#### P9301 :: BACKREST KIT :: PARTS DIAGRAM

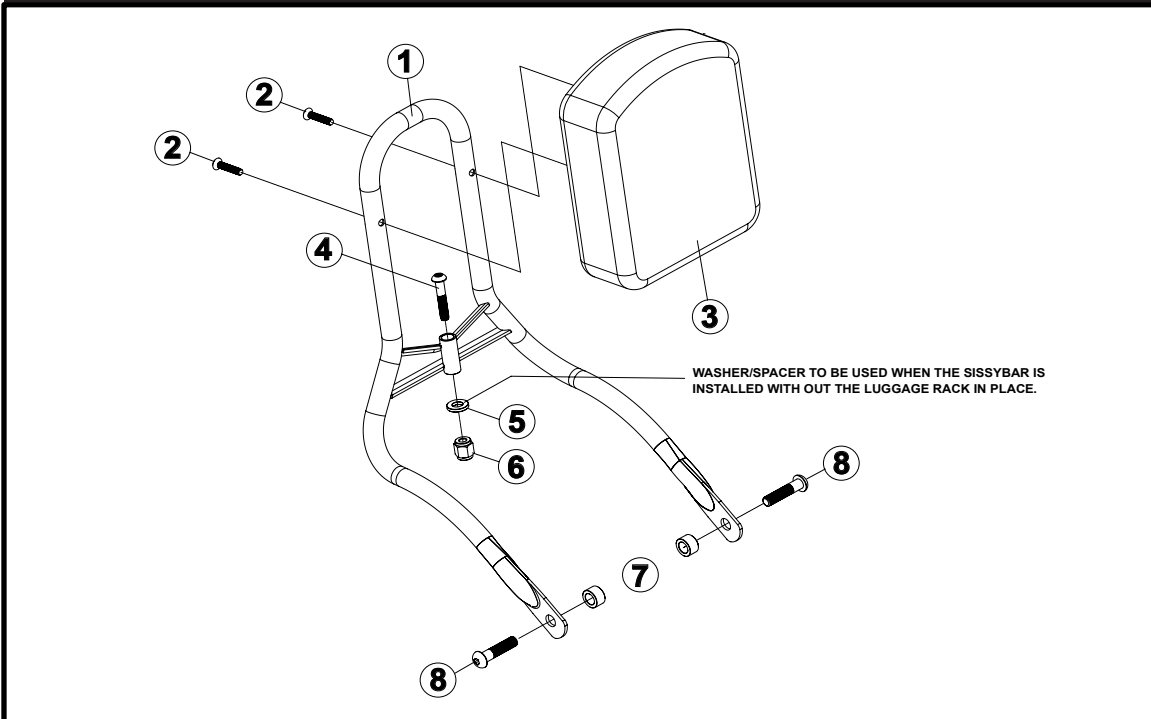

**PARTS LIST • KIT P9301 • BACKREST KIT**

ITEM NO	PART NUMBER	DESCRIPTION	QUANTITY
1	37-371480-000	SISSY BAR, WELDMENT: XV250	1
2	51-514540-000	MS,OVL,PHIL,1/4-20X1.25, STEEL, STAINLESS	2
3	70-730075-000	PAD, BACK REST	1
4	51-516445-000	CS,BUT HS,M8X45 STAINLESS W/MICRO POLISH	1
5	49-490528-000	WASHER,FLAT, ZINC PLATE	1
6	34-342874-000	BUSHING, HEX NUT, M8X1.25: XV250	1
7	49-495320-000	SPACER, FRONT, SISSY BAR: STAR XV250	2
8	51-517145-000	CS,BUTTON HS,M10-1.25X45 CHROME & BAKE	2

**P9302 :: LUGGAGE RACK KIT :: PARTS DIAGRAM**

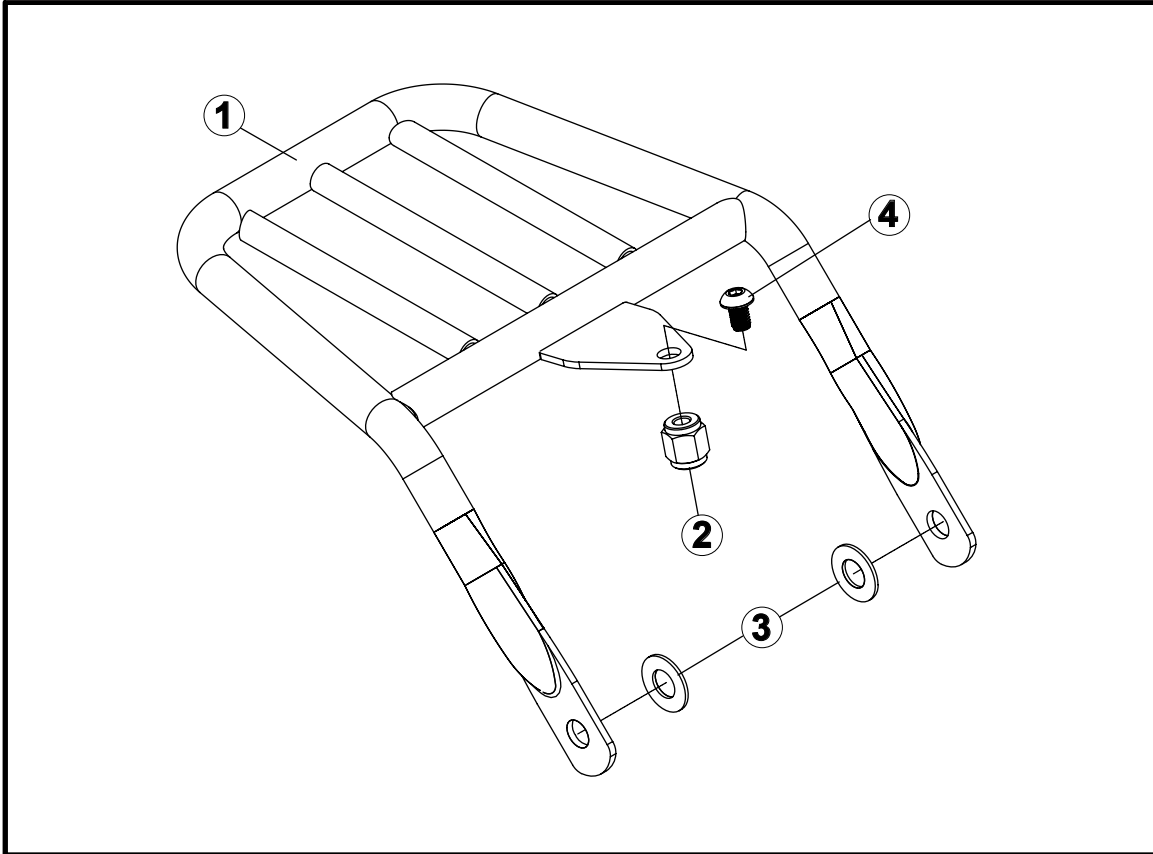

**PARTS LIST • KIT P9302 • LUGGAGE RACK KIT**

ITEM NO	PART NUMBER	DESCRIPTION	QUANTITY
1	37-374420-000	LUGGAGE RACK: STAR, XV250	1
2	34-342874-000	BUSHING, HEX NUT, M8X1.25: XV250	1
3	49-490212-000	WASHER,FLAT,.508X1.0~X.062, NYLON,BLACK	1
4	51-516412-000	CS,BUT HS,M8X12 STAINLESS W/MICROFINISH	2

## PREPARATION

Before starting the assembly process, place the motorcycle on flat, level ground. Insure that the side stand is securely in place. Cover the fenders and other cosmetic surfaces with fabric prior to the installation process.

The back rest and luggage rack kits include all necessary hardware needed for installation with the exception of the nuts used to hold the turn signals in place. We will be reusing the stock turn signal nuts for the luggage rack installation.

## P9302 :: LUGGAGE RACK INSTALLATION

1. Start the installation process by removing the dome nut that holds the rear portion of the passenger (rear) seat in place. [12mm Box Wrench] Set the hardware aside. As with many of the stock fasteners, we will not be using this item in the installation process. (Figures 1 and 2)

2. Remove the rider (front) seat from the motorcycle. The passenger (rear) seat must remain in place for luggage rack and/or sissy bar installation. To remove the front seat from the motorcycle, loosen the two Hex Cap Screws that secure the rear seat tabs in place. [12mm Box Wrench or 12mm Socket/Driver] (Figure 3)

3. With the front seat removed, disconnect the negative terminal from the battery. Use a Phillips screw driver or 10mm socket for this procedure. (Figure 4)

4. Next, locate the right and left turn signal wiring as it protrudes from the front of the rear fender. We will need to disconnect both turn signals, as well as the tail light in order to install the luggage rack. (Figures 4, 5, 6)

5. Disconnect the left side turn signal connectors first. The left side turn signal wiring is color coded black/brown. Once the turn signal wiring is disconnected, gently pull both wires through the fender, into the inside of the wheel well. Loosen the wire tabs on inside of the fender, so that the wiring and turn signal can be removed from the fender.

6. Next disconnect the right side turn signal wire terminals. The right side turn signal wiring is color coded black/green. (Figures 4, 6)

7. Disconnect the tail light wiring next. The tail lamp wiring is color coded blue/yellow/black. Once the right side turn signal and tail light wiring is disconnected, gently pull all five wires through the fender grommet, into the inside of the fender. Loosen the wire tabs on inside of the fender so that the wiring and turn signal can be removed from the wheel well. (Figures 6)

8. Remove the hex nuts located on the inside of the fender. [19mm Box Wrench] These particular nuts hold the turn signals in place. With the nuts removed, carefully pull the turn signal and wiring out of the fender mount hole. Place the nuts and turn signals in safe place, we will be using

FIGURE 1



FIGURE 2

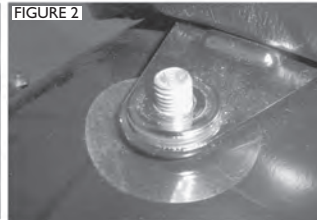

FIGURE 3



FIGURE 4

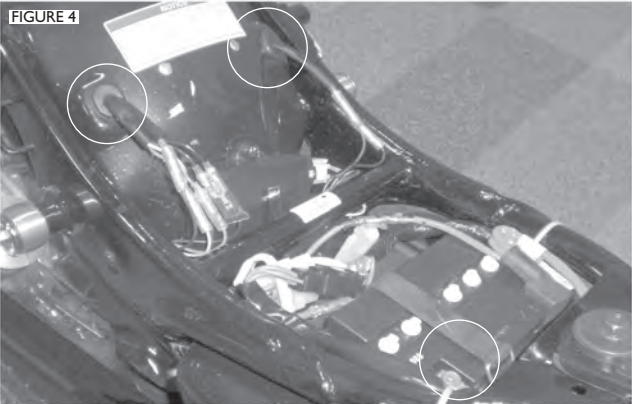

FIGURE 5

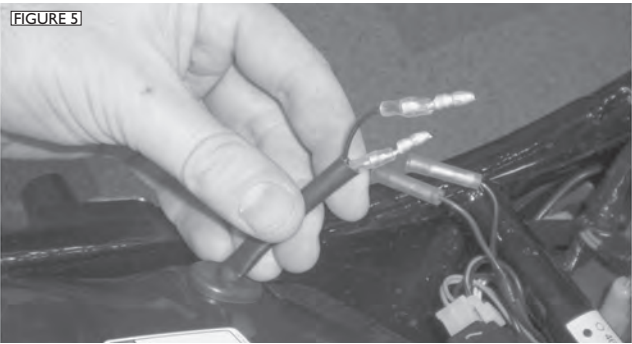

FIGURE 6



both items in the installation process. (Figures 7, 8)

9. Thread the hex nut/bushing (item #2) onto the rear pillion mounting tab. Apply thread lock to the bushing/nut. (Loctite #262 or comparable) Torque fastener to 24 Nm (18 ft/lbs). [5/8" Box Wrench and 5/8" Socket/Torque Wrench]

10. To install the luggage rack (item #1), we'll be using the turn signals as the fasteners at lower mounting points. Route the threaded end of the turn signal and wiring through the lower mounting tabs of the luggage rack. (Figure 11)

11. Next, install the plastic washers (item #3) over the threaded stalks of the turn signal, along the inside of the luggage rack mounting tabs. (Figure 11, 12)

12. Start on the right hand side of the motorcycle. Align the lower mounting tabs of the luggage rack with the turn signal mount holes on the fender. Carefully route the wiring back through to the inside of the fender. Route the turn signal nut over the wiring and secure turn signal to motorcycle fender. [19mm Box Wrench]

13. Repeat process for the left hand side of the installation. [19mm Box Wrench]

Apply a small amount of thread lock to the turn signal fasteners. (Loctite #262 or comparable) Torque fasteners to 24 Nm (18 ft/lbs).

14. Align the center mounting tab of the luggage with the threaded hole on the hex/bushing (item #2). If the sissy bar is not being installed, secure the center mounting tab with the M8x1.25x12mm button head cap screw (item #4) supplied in kit P9302. (Applicable for kit P9302 only) Apply a few drops of thread lock to the fastener and torque to 20 Nm (15 ft/lbs). (Figure 13, 14) [5mm Hex Wrench plus Hex Driver with Torque Wrench]

If the sissy bar is being installed along with the luggage rack, skip the 12mm fastener and proceed to the next step. (Sissybar Installation)

## P9301 :: SISSYBAR INSTALLATION

1. Remove the two socket head cap screws that hold the front portion of the fender in place. (Figure 15)

2. Insert the two chrome plated spacers into the right and left hand depressions of the fender brace. (Item #7) (Figure 16)

3. Align the sissy bar (Item #1) with the forward fender mounting holes. Make sure that both spacers (Item #7) are aligned properly within the inside of the mounting tabs. (Figure 17) We will be using two M10-1.25x45 button head cap screws to secure the front mounting points of the sissy bar (Item #8). Apply thread lock to both fasteners (Loctite #262 or comparable) and insert into the right and left side

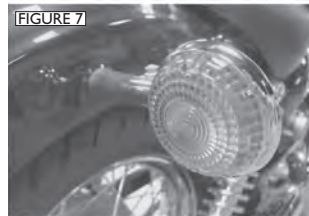

fender mount holes. Torque both fasteners to 32 Nm (24 ft/lbs). [6mm Hex Wrench plus Hex Driver with Torque Wrench]

4. Align the sissy bar (item #1) in such a way, that the rear-ward mounting point aligns with the hex nut/bushing (item #6) behind the rear pillion. If the luggage rack is not being installed at this time, install spacer washer (item #5) below the rear sissy bar mounting point. (Figure 18, 19, Parts Diagram)

5. Install the M8x1.25x45mm button head cap screw (item #4) into the rearward sissy bar mounting point. Apply a few drops of thread lock to the fastener and torque to 20 Nm (15 ft/lbs). (Figure 18, 19) [5mm Hex Wrench plus Hex Driver with Torque Wrench]

6. Install back rest pad (item #3) using the two Phillips head machine screws (item #4) supplied in this kit. (Figure 20, 21) [Screwdriver, Phillips: #3]

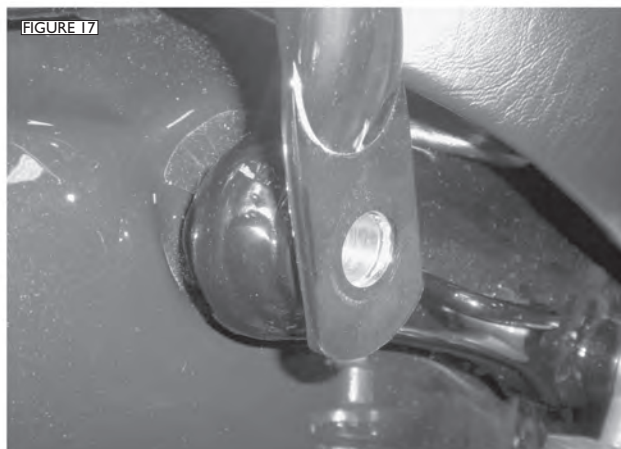

## WARNING

*Maximum load for the Luggage Rack is 5 Kg (11 lbs). Never ride your motorcycle with loose accessory mounting hardware. Check the hardware for proper torque values regularly.*

*Today's motorcycles are built with enough frame rigidity to withstand the moderate loads imposed on them by the foreseeable additions of accessory(ies).*

*If the accessory(ies) adversely affect your motorcycle's stability, immediately remove the accessory(ies). Do not ride a motorcycle that exhibits unsafe handling characteristics. Have experienced service personnel correct any problem before riding with the unsafe accessory(ies) installed. For further questions concerning handling problems associated with any accessory(ies), contact your dealer, motorcycle manufacturer, or accessory manufacturer.*