



INSTALLATION INSTRUCTION
National Cycle Chrome Lower N76609
For installation with SwitchBlade® Mount Kit

Chrome Lowers for installation with SwitchBlade Windshields and the SwitchBlade Mount Kit.

Dealers: If installing the Chrome Lower Kit for a customer please give them this manual. It contains information needed to properly maintain and use this product.

Attention



Special notes and cautionary measures which can prevent damage to the accessory or motorcycle.

Note:



Tips for facilitation of operation, control and adjustment, as well as maintenance work.

N76609 Chrome Lowers are engineered to install to a National Cycle SwitchBlade Mount Kit. You must have a SwitchBlade windshield mount kit mounted on your motorcycle or have purchased this kit prior to installing the chrome lowers. These Kits include but are not limited to: Kit Q202, Q203, Q204 and Q205.

When mounting the chrome lowers re-use all hardware from your SwitchBlade Mount Kit with the exception of the Spiders. The Spiders supplied with the lowers have longer studs necessary for proper installation.

Proper tightening of this assembly is critical. Use a Torque Wrench! Follow this procedure! Correct assembly of this kit will provide years of reliable service.

Parts List

INDEX	DESCRIPTION	QTY.
1	30-307640-000 Chrome Lower Left	1
2	30-307641-000 Chrome Lower Right	1
3	37-370164-TL0 Spider with Thread Locker	2

PREPARATION

1. Locate the Installation Manual from the SwitchBlade Mount Kit.

2. Position the motorcycle securely on its stand or a work stand.

3. Cover the front fender and fuel tank with a suitable cloth to avoid scratches from dropped tools.

4. If you have the SwitchBlade mount kit on your motorcycle, remove clamps.

5. Use the Spiders from the Chrome Lower Kit to install the Clamps in the precise location as specified in the SwitchBlade Mount Kit Installation Manual. **Figure 1.**

The longer stud of the spider goes to the TOP of the fork.

6. Place the Mount Cup over the Spider stud as directed in your SwitchBlade Mount Kit Installation Manual.



4mm Hex Key Wrench and Hex Bit Socket

Torque Wrench that accurately measures to 75 inch pounds. (6.25/lbs) (8.6 Nm)

Installation Manual from your SwitchBlade Mount Kit.

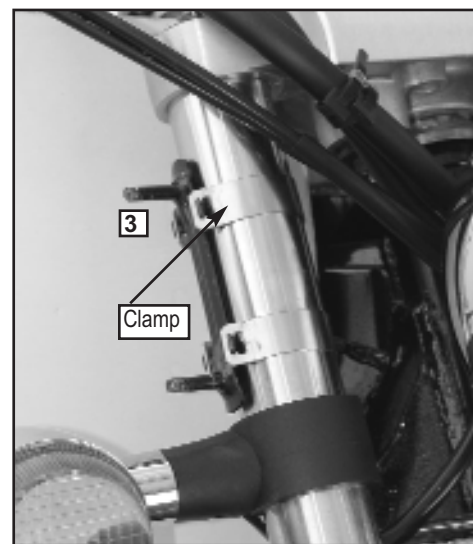

Figure 1.

The forks of your motorcycle and the location of the spider may differ from photo. Refer to your SwitchBlade Mount Kit Installation Manual.

INSTALLATION of N76609

1. Select the appropriate Chrome Lower for the left or right side of the motorcycle. Place Lower on stud of Spider. Place Brass Washer on upper stud to the outside of the Chrome Lower. **Figure 2.**
2. Push the large Upper Nut into the large Upper Spool so the **thick side** of the spool is near the head of the Upper Nut. **Figure 3.**
3. Start the Upper Nut/Spool onto the Upper Stud. (4mm Hex Key)
4. Assemble the Lower Spool and Lower Nut so the **thick side** of the Spool is near the head of the Lower Nut.
5. Start the Lower Nut/Spool onto the lower stud. (4mm Hex Key)



To check location of brackets for your motorcycle refer to the Installation Manual from your SwitchBlade Mount Kit.

6. Repeat steps 1 through 5. on the other fork.
7. Tighten the Nuts to 75 INCH POUNDS (8.6 Nm) (6.25 ft/lbs) (Torque Wrench).



Misalignment can cause damage to fuel tank and will cause the system to not work properly. Check alignment carefully. **Turn the fork carefully to the stops.** Make sure the gap between the Spools and the fuel tank are the same on both sides and Chrome Lower clear tank and all parts of motorcycle

8. Cycle the shield through the mount and dismount 5 times.

9. Retighten the Nuts to 75 INCH POUNDS (8.6 Nm) (6.25 ft/lbs).



MAINTENANCE

The high quality chrome finish of your National Cycle Chrome Lower can be maintained with any quality chrome cleaner and / or polish applied with a soft cloth.



Check hardware for tightness regularly. Never ride with loose mounting hardware. Check to be sure your Chrome Lower do not contact any part of the motorcycle at a full turn left and right. Correct any problem before using the motorcycle.

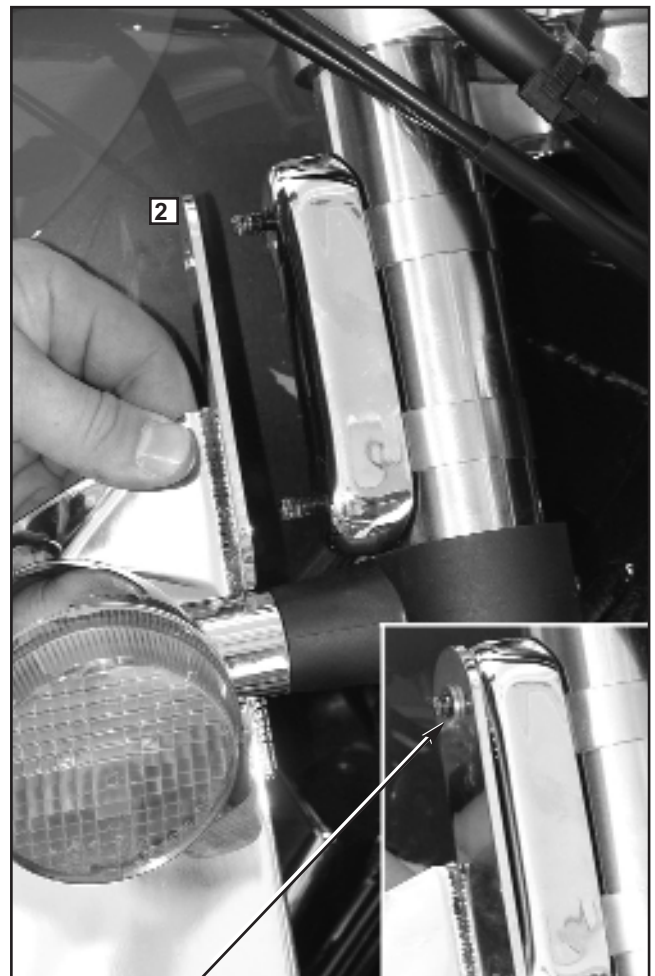

Figure 2.

Place Brass Washer on outside of Chrome Lower!

The forks of your motorcycle and location of the spider may differ from the photo. Refer to your mount kit installation manual

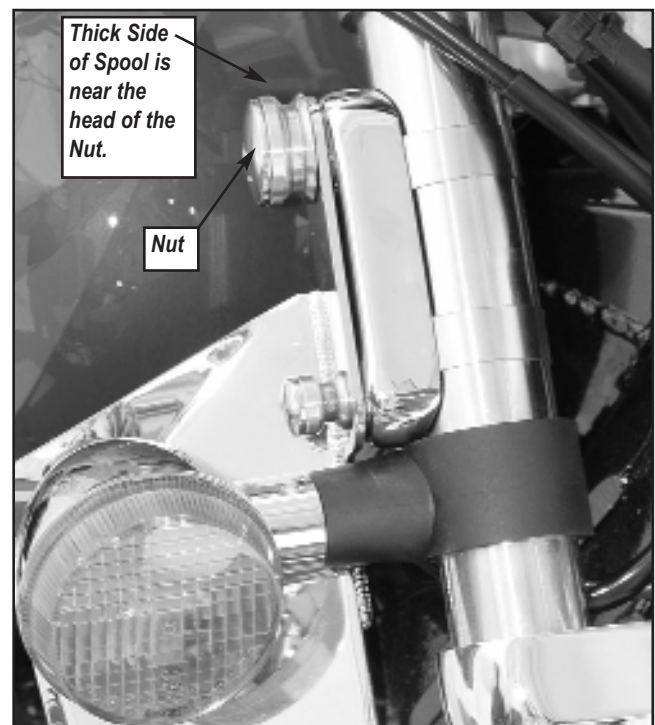

Figure 3.