



INSTALLATION INSTRUCTION

National Cycle Chrome Lower N76606

For installation with SwitchBlade Mount Kits: Q341 and Q342

Dealers: If installing the Chrome Lower Kit for a customer please give them this manual. It contains information needed to properly maintain and use this product.

Attention



Special notes and cautionary measures which can prevent damage to the accessory or motorcycle.

Note:



Tips for facilitation of operation, control and adjustment, as well as maintenance work.



N76606 Chrome Lower are engineered to install to a National Cycle SwitchBlade Mount Kit. You must have a one of the following SwitchBlade Mount Kits mounted on your motorcycle or have purchased this kit prior to installing the chrome lowers. These Kits include: Kit Q341 (without factory light bar) and Q342 (with factory light bar.)



Installation is less than 10 minutes, but please follow the instructions for your mount kit!



Proper tightening of this assembly is critical. Use a Torque Wrench! Follow this procedure! Correct assembly of this kit will provide years of reliable service.

Parts List

INDEX	DESCRIPTION	QTY.
1	30-307670-000 Chrome Lower Left	1
2	30-307671-000 Chrome Lower Right	1
3	51-514618-000 Screw, 5/16-24 x 2 1/4	2

PREPARATION

1. Position the motorcycle securely on its stand or a work stand.
2. Cover the front fender and fuel tank with a suitable cloth to avoid scratches from dropped tools.

INSTRUCTIONS FOR CHROME LOWER WITH KIT Q341 (SEE PAGE 2 FOR Q342)

1. Remove the Upper and Lower Spools from one side of the mount kit. Remove the Roller Cap from the Upper Spool, and reverse, thin side of spool is against Chrome Lower now (Figure 1). Keep Cushion in place.
2. Refer to figure 1. and install Chrome Lower. Use the supplied 2 1/4" Screws at the upper location. Be certain to reverse the Spools so the thin side of the Spool is against the Chrome Lower. Repeat on opposite side.
3. Tighten the Nuts to 15 ft-lbs (21 Nm) (Torque Wrench).
4. Check clearances. **Turn the fork carefully to the stops.** Make sure the Chrome Lower clear tank and all parts of motorcycle.
5. Cycle the shield through the mount and dismount 5 times.
6. Retighten the Nuts to 15 ft-lbs (21Nm).



3/16" Hex Key Wrench

Torque Wrench that accurately measures to 15 ft-lbs (21 Nm)

If necessary, the Installation Manual from your original Mount Kit.

Installation with Kit Q341

ThinSide of Spool is against Chrome Lower. Keep Cushion in place inside Spool

3

2

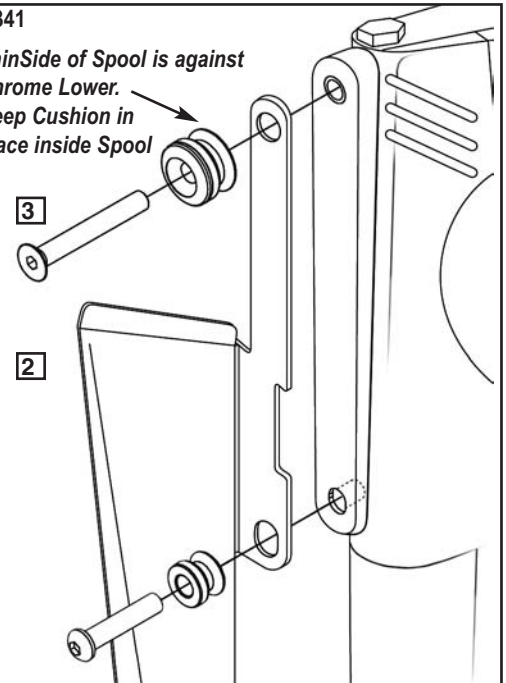

Figure 1.

INSTRUCTIONS FOR CHROME LOWER WITH KIT Q342

1. Remove the Upper and Lower Spools from one side of the mount kit. Remove the Roller Cap from the Upper Spool, and reverse, thin side of spool is against Chrome Lower now (Figure 2). Keep Cushion in place.
2. Refer to figure 2. and install Chrome Lower. Use the supplied 2 1/4" Screws at the upper location. Be certain to reverse the Spools so the thin side of the Spool is against the Chrome Lower. Repeat on opposite side.
3. Tighten the Nuts to 15 ft-lbs (21 Nm) (Torque Wrench).
4. Check clearances. **Turn the fork carefully to the stops.** Make sure the Chrome Lowers clear tank and all parts of motorcycle.
5. Cycle the shield through the mount and dismount 5 times.
6. Retighten the Nuts to 15 ft-lbs (21Nm).

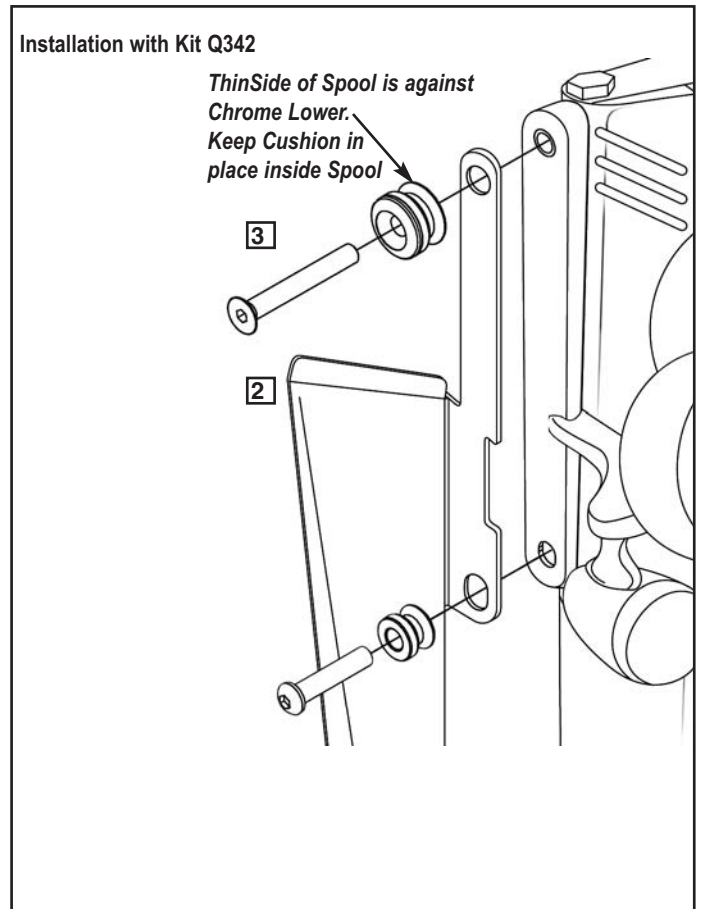

Figure 2.

MAINTENANCE

The high quality chrome finish of your National Cycle Chrome Lower can be maintained with any quality chrome cleaner and / or polish applied with a soft cloth.

Check hardware for tightness regularly. Never ride with loose mounting hardware. Check to be sure your Chrome Lowers do not contact any part of the motorcycle at a full turn left and right. Correct any problem before using the motorcycle.