



INSTALLATION AND OWNERS MANUAL Chrome Deflector N762 and 763A

NOTE: This accessory can only be used in conduction with National Cycle “CJ” series “B” series or “J” series Windshield Mounting kits.

QTY	DESCRIPTION	PARTS LIST	QTY	DESCRIPTION
1	Hex Key, 5/32”		1	Deflector Left
1	Wrench, 7/16”		1	Deflector Right

NOTE: Follow preparation and installation steps on page two if your windshield mounting kit is CJG, CJJ, CJK or CJL.



QTY	DESCRIPTION	PARTS LIST	QTY	DESCRIPTION
1	Hex Key, 5/32”		1	Deflector Left
1	Wrench, 7/16”		1	Deflector Right

PREPARATION FOR INSTALLATION WITH CJ SERIES KITS

1. If a Windshield is already installed, remove windshield and set kit aside.
2. If a windshield is being installed for the first time, prepare the Fork Clamps 370011 and 370011 from your Windshield Mounting kit with the rubber spacers, as described in the Mount Kit Installation Instructions.

INSTALLATION

1. Hold the Fork Clamp in assembled position onto the Right fork tube, 370010 on the inside and 370011 on the outside.
2. Hold the appropriate Deflector in position against the fork clamp.
3. Put a ½ button Head Screw through the upper hole in the Deflector and both clamp halves, start a nut on the screw and tighten until snug (Hex Key and Wrench).
4. Repeat Step 3 on the lower hole.
5. Repeat Steps 1 through on the Left Fork tube.
6. Install the Windshield according to the instructions provided with the windshield Mounting Kits. (Wrench, 7/16” quantity 2)
7. Verify that the Deflectors do not interfere with the forks.
8. After the final adjustments are complete, tighten all fasteners as specified in the Mounting Kit/Windshield Installation Procedure

INSTALLATION INSTRUCTIONS: When mounting chrome Deflectors using Windshield Mounts Kits: CJG, CJH, and CJJ THROUGH C JL. These kits use 1/8" 3/5" wide offset brackets

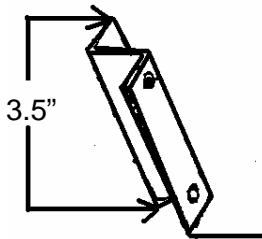

Spacer Block

QTY	DESCRIPTION	PARTS LIST	QTY	DESCRIPTION
1	Hex Key, 5/32"		1	Deflector Left
1	Wrench, 7/16"		1	Deflector Right

1/8" Thickness

PREPARATION

1. If a Windshield is already installed, remove windshield and set it aside.
2. If a Windshield is being installed for the first time, prepare the Fork Clamps, marked 370010 and 370011 from your Windshield Mounting kit with the rubber spacers, as described in the Mount Kit Installation Instructions.

INSTALLATION

1. Hold the Fork Clamp in assembled onto the Right Fork tube, 370010 on the inside and 370011 on the outside.
2. Hold the appropriate Deflector in position against the Fork Clamp.
3. Put a 1/2" Button Head Screw through the middle hole in the Deflector and both clamp halves, start a nut on the screw and tighten until snug(Hex Key and Wrench).
4. Repeat steps 1through 4 on the other fork tube.
5. Install the Windshield according to the instructions provided with the Windshield Mounting Kits. (Wrench, 7/16"quantity 2)
6. Verify that the front fork of the motorcycle turns freely without binding. Correct any problem before riding.
7. After the final adjustments are complete, tighten all fasteners as specified in the Mounting Kit/Windshield Installation Procedure.

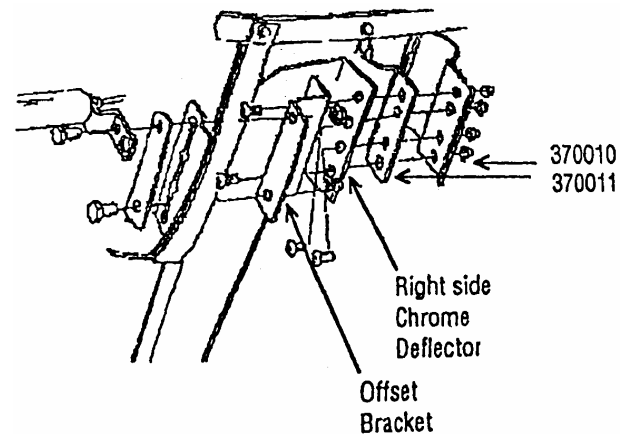

Maintenance/Caution

The high quality chrome finish of our National Cycle Chrome Lower can be maintained with any quality chrome cleaner and /or applied with a soft cloth.

Check hardware for tightness regularly. Never ride with loose mounting hardware

Check to be sure your Deflectors do not contact any part of the motorcycle at a full turn left and right. Correct any problem before riding.