



INSTALLATION INSTRUCTIONS and TEMPLATES

For Suzuki C109R

N7206, Front of Front Fender Tip- Page 1

Template for Front Fender Tip-Page 3

Rear of Front Fender Tip- Page 2

Attention



Special notes and cautionary measures which can prevent damage to the accessory or motorcycle.

Note:



Tips for facilitation of operation, control and adjustment, as well as maintenance work.

PARTS LIST FOR N7019

Part	Description	Qty.
70-710086F-000	Front of Front With Applied, Foam Tape Template included with this installation instruction	1
70-710086R-000	Rear of Front	1
Parts from Bag #500 that will be used in front of front installation		
42-450011-001	Nut, Hex	1
49-490531-000	Washer	1
77-770200-000	Alcohol Wipe	1
Wrapped with instruction sheet		



TOOLS REQUIRED:

Flexible Measuring Tape
Power Drill with 3/16" Drill Bit
Grease Pencil or Crayon
Cellophane Tape
3/8" Open End Wrench
Thin piece wood that fits between Fender & Tire
Template located on page 3

Additional parts are used in Rear of Front Tip Installation, page 2

PREPARATION

The front of front fender tip combines a hidden screw, with 3M tape installation. Please follow the instructions below for proper installation.

Allow time for the 3M® brand quality tape to cure for 24 hours at 70-90° F (21-32° C) before washing, waxing or riding the motorcycle.

1. Thoroughly wash fender where Fender Tip will be installed. Area where Tip will mount should be free of all dirt, wax, soap or other residue. The 3M® brand tape will adhere extremely well when applied to a clean area.

INSTALLATION

- Find Center of the Fender
 - To find center of fender, place a measuring tape across fender. Use easy to find points for the start and end of this measurement. Divide this measurement by two, and mark the corresponding spot on the Tape. **(Tape measure, Grease Pencil) Figure 1**
- Place Template
 - Align the **FRONT LOWER EDGE OF TEMPLATE** to be flush with the **LOWER EDGE OF THE FENDER**, matching center line of template with marked center point. Be certain to align front lower edge of template. Do not be concerned if outer edges do not match. Secure the template onto the fender with **cellophane tape**.
- Do a visual alignment.
- Drill Center Hole. Area between front fender and tire is tight. **DO NOT** drill into tire. Place a thin piece of wood between the fender and the tire to avoid tire damage. **(Power Drill with 3/16" Drill Bit.) Figure 2**
- Install Fender Tip
 - Remove liner from tape. Position Fender Tip at edge of fender and insert mounting stud through hole in fender.
 - Squeeze sides of tip against fender.
 - Place a Washer onto the stud and secure with Hex Nut.
 - Carefully tighten nut with wrench. The nut should be tight enough to avoid rattles.
 - Check the tightness of the nuts regularly.

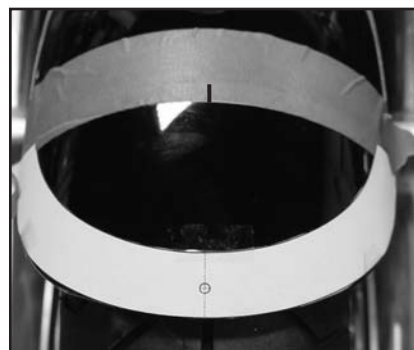

Figure 1

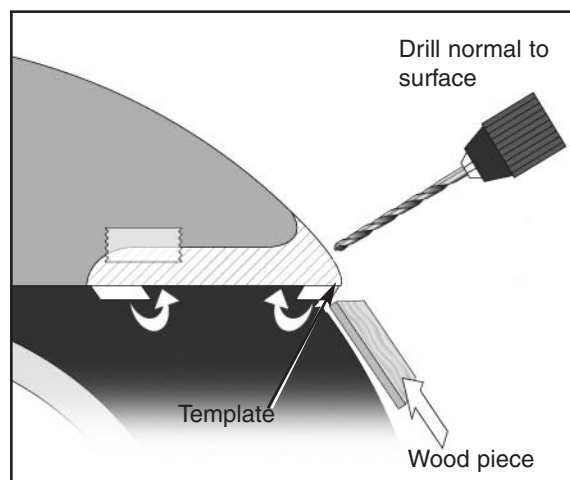

Figure 2

INSTALLATION INSTRUCTIONS

For Suzuki C109R

N7207, Rear of Front Fender Tip

Attention



Special notes and cautionary measures which can prevent damage to the accessory or motorcycle.

Note:



Tips for facilitation of operation, control and adjustment, as well as maintenance work.

PARTS LIST FOR N7206 REAR OF FRONT FENDER

Part	Description	Qty.
70-710086-000	Rear of Front Fender	1
BAG #588		
42-423050-000	Nut, Nylok	2
49-490531-000	Washer	2
55-568216-000	Screw, M5	2

TOOLS REQUIRED:

Masking Tape
Marking Pen
Small Wood Block 1/2" Thick (not shown)
Center Punch
Power Drill with 7/32" Drill Bit
5/16" Wrench
No. 2 Phillips Screwdriver



PREPARATION:

1. Position motorcycle securely on its centerstand or a work stand.
2. Clean the fender thoroughly.

INSTALLATION

1. Cover the area of the fender where the Fender Tip will mount with a thin layer of masking tape. Make certain the tape is smooth.
 2. Carefully, position the Rear of Front Fender Tip on the fender, make sure the Tip is centered on the fender. **Figure 1**
 3. Mark the hole locations with the marking pen. **Figure 2**
 4. Remove the Fender Tip.
 5. To avoid the drill slipping on the fender, use the Center Punch to make an impression at the center of your mark. Drill holes through the fender at the marks. **Figure 3**
-  **Due to close clearances between front fender and tire, place block of wood between the fender and the tire to avoid tire damage. Figure 3**
6. Remove the masking tape.
 7. Position the Fender Tip, and squeeze fender toward tip. Insert the Screws from the outside. Install the Washers and Nuts to the inside. Tighten securely. **Figure 4**



Figure 1



Figure 2



Figure 3

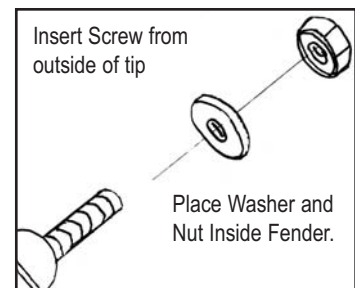
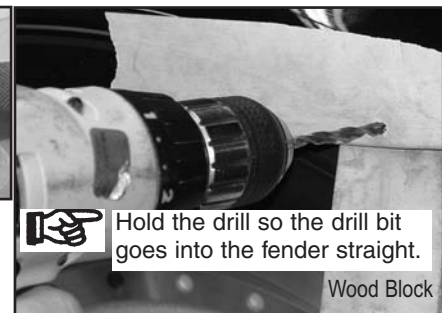
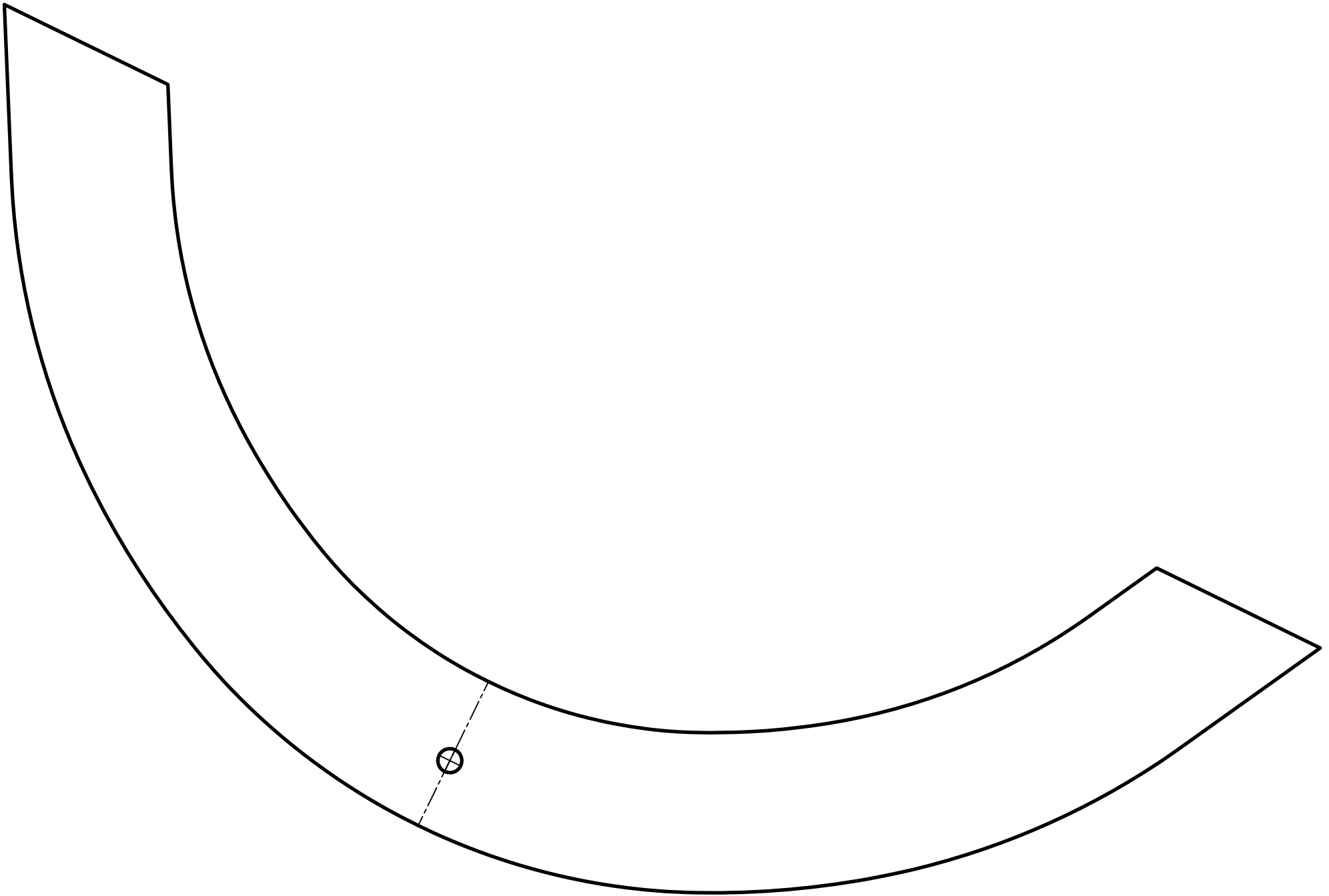

Figure 4

MAINTENANCE

Clean and polish with a chrome cleaner/polish.
Check tightness of the nuts regularly.



Discover other custom accessories & trim on our website.