

Description:	FlyScreen™ <b>Light Tint    Dark Tint</b>	Model:	Various Motorcycles, Fork Diameter 44-51mm
Part Number:	<b>Chrome Mounts:</b> N2556-001, N2557-001 <b>Black Mounts:</b> N2556-002, N2557-002	Installation Time:	30 min.

Thank you for purchasing a National Cycle product. Read these instructions carefully and thoroughly before beginning work. Dealers, if installing this windshield for a customer, please give them this manual. It contains information needed to properly maintain and use this product.



### Attention:

Special notes and cautionary measures which can prevent damage to the accessory or vehicle.



### Note:

Tips for facilitation of operation, control and adjustment, as well as maintenance work.

## Parts List, See Page 2



## CLEANING AND MAINTENANCE

To clean the screen, wash with a clean soft cloth, plenty of warm water and if necessary, a non-abrasive soap such as dishwashing liquid. Flannel or soft chamois make good cleaning cloths. **Paint, glue residue or grease removal:** Moisten cotton with naphtha or turpentine followed by a wash as above.

National Cycle **Shield Wash™** (N1401-01) makes a good daily cleaner and comes with a handy travel size bottle. Shield Wash is safe for all windshields and helmet visors.

Do not clean the screen with glass cleaners.

Do not allow brake fluid, alcohol, or strong solvents to contact the screen.

## RAIN REPELLENT

Do not use rain protective products made for glass. We recommend National Cycle's **RainZip®** (N1410-01) to help shed water in rainy weather.

## WARNING

Never ride your motorcycle with loose accessory mounting hardware. Check the hardware for tightness regularly.

Today's motorcycles are built with enough frame rigidity to withstand the moderate loads imposed on them by the foreseeable addition of an accessory(ies). If an accessory(ies) adversely affects your motorcycle's stability, immediately remove the accessory(ies). Do not ride a motorcycle that exhibits unsafe handling traits.

Have experienced service personnel correct any problem before riding with the accessory(ies) installed. For further questions concerning handling problems associated with an accessory(ies), contact your dealer, motorcycle manufacturer, or accessory manufacturer.

**Sunlight reflected off the inside curvature of the windscreen can, at certain times of day, cause extreme heat buildup on the motorcycles instruments and possibly even melt them. Exercise care in parking to avoid this. Park your motorcycle facing the sun or place an opaque object over this area.**

**Parts List For Kit-FJ-002, Chrome Finish. Supplied with N2556-001 and N2557-001**

Item	Part No.	Description	Qty.	Notes and Tools
<b>BAG#1267</b>				
1	37-371831-000	Outer Clamp, Chrome	2	
2	37-371830-000	Inner Clamp, Black	2	Nut Welded to Bracket
3	75-764012-000	.047" Rubber Spacer	2	Scissor
4	75-764011-000	.062" Rubber Spacer	2	"
5	75-764014-000	.094" Rubber Spacer	2	'
<b>BAG#025</b>				
6	37-371142-000	Bracket, Offset, Curved Chrome, Left	1	
7	37-371140-000	Bracket, Offset, Curved Chrome, Right	1	
8	51-515720-000	Screw, 8mm Allen	4	6mm Hex Wrench
9	49-492550-000	Washer, Serrated, External	4	

**Parts List For Kit-FJ-003, Black Finish. Supplied with N2556-002 and N2557-002**

<b>Bag#1268</b>				
1	37-371832-000	Outer Clamp, Black	2	
2	37-371830-000	Inner Clamp, Black	2	Nut Welded to Bracket
3	75-764012-000	.047" Rubber Spacer	2	
4	75-764011-000	.062" Rubber Spacer	2	
5	75-764014-000	.094" Rubber Spacer	2	
<b>BAG#1234</b>				
6	37-371143-000	Bracket, Offset, Curved Black, Left	1	
7	37-371141-000	Bracket, Offset, Curved Black, Right	1	
8	51-515720-000	Screw, 8mm Allen	4	6mm Hex Wrench
9	49-492550-000	Washer, Serrated, External	4	

**BAG#1267 and BAG#1268**

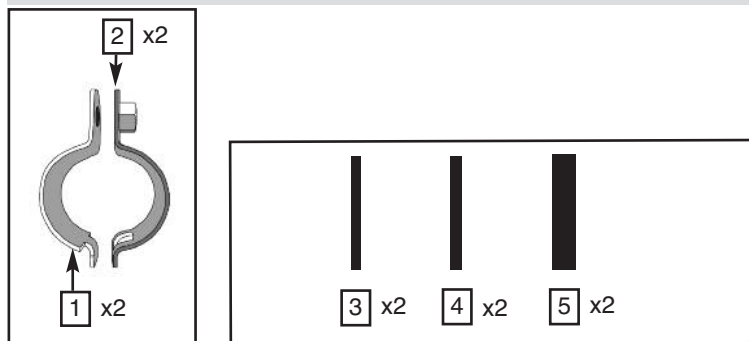

**BAG#025 and BAG#1234**

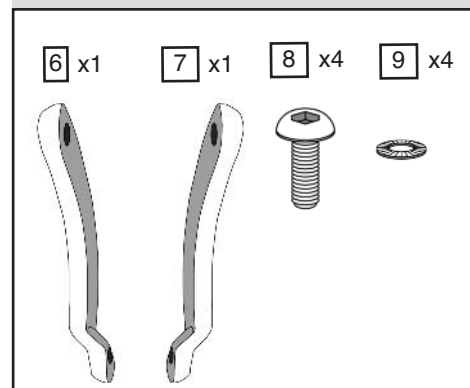

**Tool List:**

- Tape Measure or Caliper (to measure fork)
- Scissor
- 6mm Hex Wrench

## WINDSHIELD INSTALLATION

### Preparing the Fork Clamps

1. Measure the motorcycle fork:

Diameter of Tube: \_\_\_\_\_

Width, Center to Center: \_\_\_\_\_

(Caliper or Soft Tape Measure) **Figure 1**

2. Refer to the Gasket Chart below and select the correct gaskets for your motorcycle fork diameter.

 One Gasket Strip is required for each fork.

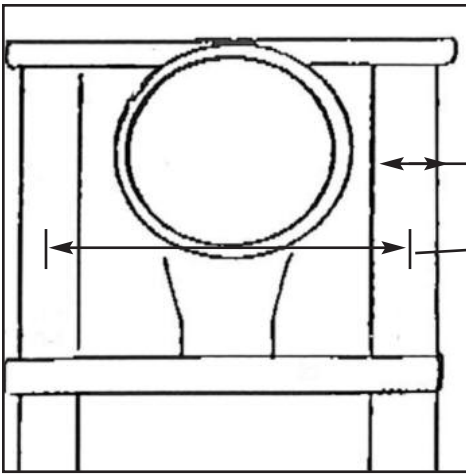

Figure 1

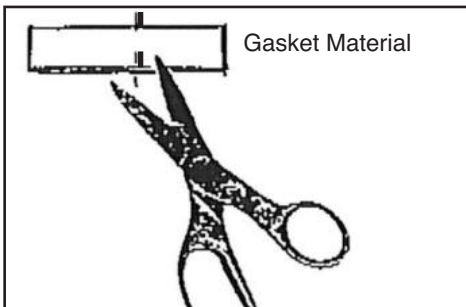

Figure 2

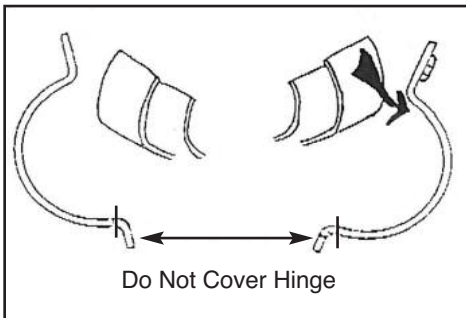

Figure 3

### Gasket Chart

Fork Diameter	Qty.	Gasket Gauge Needed	
44mm	2	.094"	.062"
45mm	2	.047"	.094"
49mm	2	.062"	
51mm	2	.047"	

3. Cut each Gasket into 2 pieces. You will need 1 piece for each **half** of the Clamp. **(Scissor) Figure 2**

4. Before removing paper backing from Gasket, fit Gasket to Clamp to verify correct length. Cut Gasket material to exact length of Clamp half. **(Scissor) Figure 2 and 3**

**Figure 2 and 3**

5. Remove paper backing and apply the required Gasket(s) to each Clamp half. **Do Not Apply Gasket Over Hinge. Figure 3**

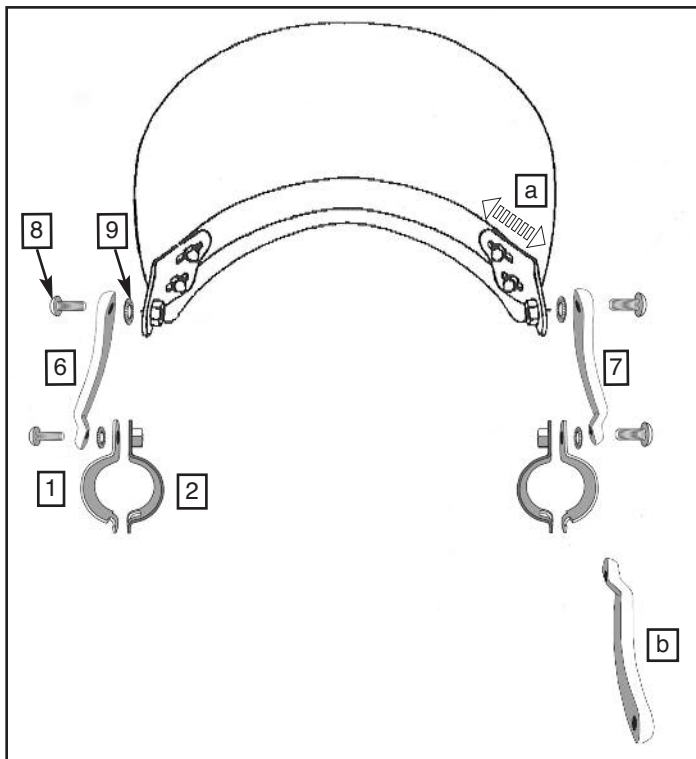

Figure 4

### Assemble Offset Brackets to Windscreen

6. Use the fork width measurement to determine:
  - a. Adjustment of Inside Plate Bracket
  - b. Adjustment of Offset Bracket (6 and 7)

7. Change the position of the Offset Bracket (6 and 7) and the slotted Plate Bracket for Windshield to fit the motorcycle fork width. **Figure 4**

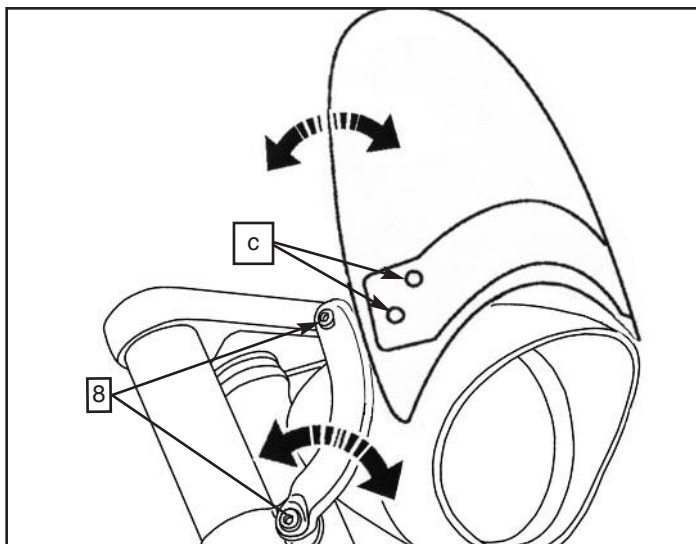

Figure 5

### Install Windshield to Fork with Fork Clamps

8. Hold Windshield up to the motorcycle to check adjustment and determine Fork Clamp Position.
9. Hold Inner Clamp (2) to inside of fork tube, hook Outer Clamp (1) to the Inner Clamp.
10. Secure Clamp Assembly to the Offset Bracket with remaining M8 Screw (8) and Washer (9). (6mm Hex Wrench) **Figure 4 and 5**

### Final Adjustments and Tightening

11. Adjust the Windshield to the desired position and securely tighten the 4 Screws (8). **(6mm Hex Wrench) Figure 5**
12. Securely tighten the 4 Screws in the Windshield Plate Bracket (c). **(4mm Hex Wrench and 10mm Socket) Figure 5**