

**PARTS LIST**

Index	Description	Qty.
1	Windshield Assembly	1
<b>Bag 210A</b>		
2	Offset Bracket, Chrome	2
3	Washer, 3/8" ID x 1" OD	4
4	Washer, Flat, 5/16"	4
5	Screw, M8 x 20 x 1.25	2
6	Screw, M8 x 40 x 1.25	2

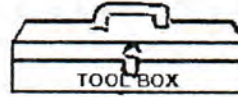

8mm Hex Wrench  
 Tools to remove original headlight lens and mount bolt.

**INSTALLATION**

1. Assemble chrome brackets to windshield assembly as shown in diagram.
2. Hold windshield assembly in place to motorcycle headlight mount points. Adjust the width of the windshield mount brackets to match width of headlight mount points by loosening the M5 cap nuts and sliding the black mount plate as necessary. Retighten M5 cap nuts.
3. Refer to the Motorcycle Owner's Manual to remove the headlight lens. Remove the headlight bracket mounts bolts. Store bolts. They will not be reused.
4. Install Windshiled assembly to headlight mount points using the external washers and M8-1.25 x 40 screw.
6. Tighten all fasteners.

**NOTE:** Right and Left side of Motorcycle is determined while sitting on the bike.

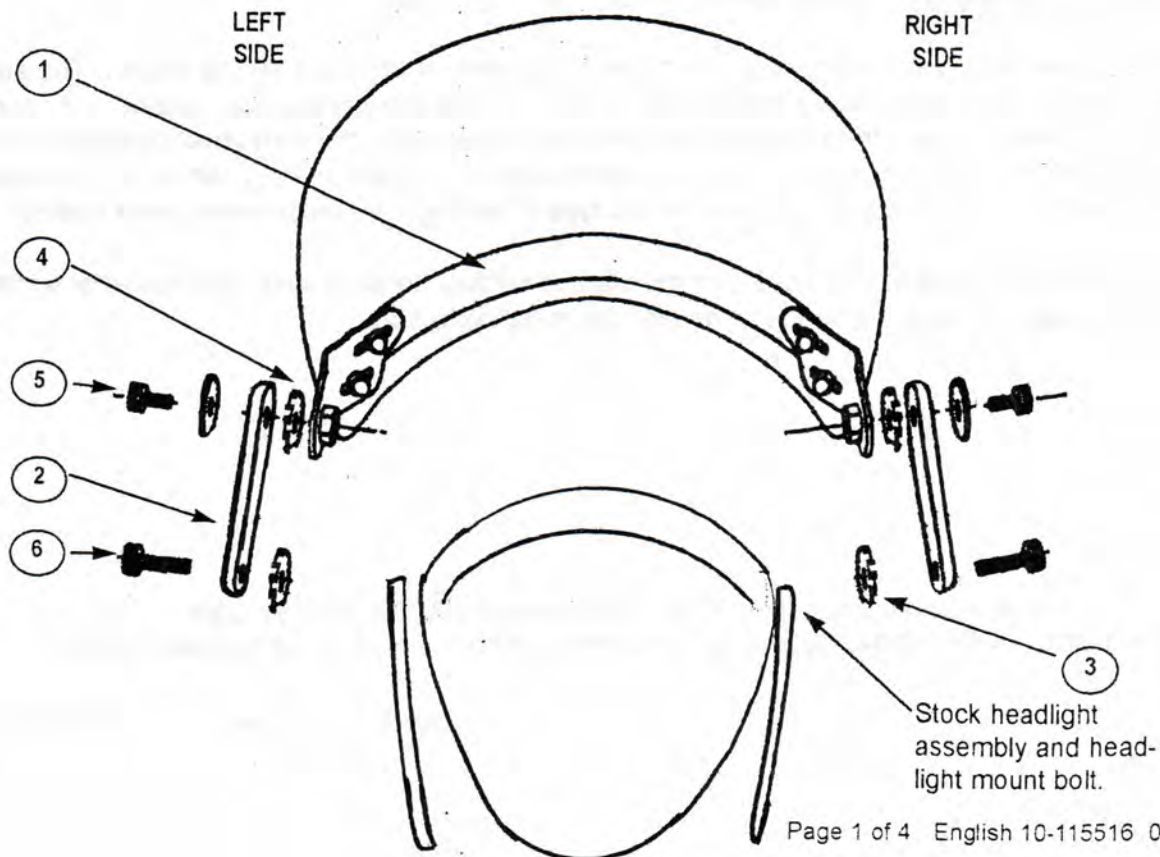
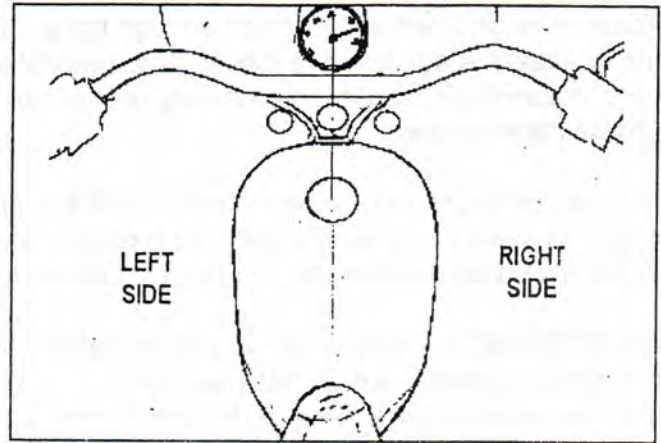

## **WARNING / MAINTENANCE**

**WARNING** National Cycle windshields and fairings are designed to provide wind protection and increased riding comfort, but not protection in the event of a collision with another vehicle, the road, birds, or any other object.

Our products utilize certain features, patented and otherwise, that may minimize injury in certain accidents, but the possibility of injury exists if the screen is broken or if impacted by an object. Always wear eye protection, helmets and protective clothing. Never ride your motorcycle while under the influence of drugs or alcohol.

All of our products are made in conformance and exceed the requirements of D.O.T. SS205, Z26.1, classifications AS6 and AS7, which covers all safety glazing for motorcycle application. Never ride your motorcycle with loose windshield mounting hardware. Check the hardware for tightness regularly.

Today's motorcycles are built with enough frame rigidity to withstand the moderate loads imposed on them by the foreseeable addition of a fork mounted windshield. If the addition of an accessory(ies) adversely affects your motorcycle's stability, immediately remove the accessory(ies). Do not ride a motorcycle that exhibits unsafe handling traits.

Have experienced service personnel correct any problem before riding with the accessory(ies) installed. For further questions concerning handling problems associated with an accessory(ies), contact your dealer, motorcycle manufacturer, or accessory manufacturer.

**MAINTENANCE** To clean the screen, wash with a clean soft cloth, plenty of warm water and, if necessary, a non-abrasive soap such as dishwashing liquid. Flannel or soft chamois make good cleaning cloths. Paint, glue residue or grease removal: Moisten cotton with Naphtha or Turpentine followed by a wash as above. Apply a high quality plastic cleaner, such as McGuir's Mirror-Glaze MG-17 or Novus #2, to the screen. This will leave a protective coating in the screen making future cleanings easier.

Do not clean the screen with glass cleaners. Do not use rain protective products on the screen. The solvent action of the alcohol in these products will destroy the screen. Do not allow brake fluid, alcohol, or strong solvents to contact the screen or penetrate between the chrome brackets and the Permanent damage will result! To remove fine scratches, use a very soft clean cloth and a fine grade buffing compound. Jewelers rouge or McGuir's Mirror-Glaze MG-10 are best for this type of buffing. We recommend hand buffing.

**STORAGE** Do not use low quality vinyl covers or old shower curtains to store your motorcycle or windshield. These products damage the plastic of windshields and the motorcycle body.