

**Kit Q142 and Q143 SwitchBlade Windshield Mount Kit for installation with SwitchBlade Windshields: 2-UP™, Chopped™, Shorty™ or Deflector™**

**Dealers:** If installing the mount kit for a customer please give them this manual. It contains information needed to properly maintain and use this product.

The Switchblade™ Mount Kit will allow you to mount any of the four styles of SwitchBlade windshields to the motorcycle this kit is installed on. Contact your dealer or National Cycle for complete information for all four SwitchBlade Windshields: 2-Up™, Chopped™, Shorty™, and Deflector™ *All Patents Pending*

**Attention**



Special notes and cautionary measures which can prevent damage to the accessory or motorcycle.

**Note:**



Tips for facilitation of operation, control and adjustment, as well as maintenance work.

Before you begin installation, please read through this guide carefully and check the parts list against the items in the kit. We recommend that installation is by a qualified technician.

**PARTS LIST**



You will find Kit Q142 and Q143 parts lists on page 3 of this guide.

	1, Hex Key Wrench, 5/32"
	1, Torque Wrench that accurately measures 75 inch pounds. (6.25 ft-lbs) (8.6 Nm)

**Preparation**



**Proper tightening of this assembly is critical. Use a Torque Wrench!**

Follow this procedure! Correct assembly of this kit will provide years of reliable service.

Position the motorcycle securely on its stand or a work stand. Cover the front fender and fuel tank with a suitable cloth to avoid scratches from dropped tools.

**INSTALLATION**

1. Insert a Cushion into the side of each Upper Spool as shown in figure 2.

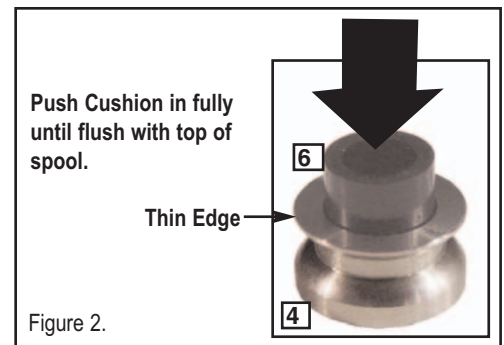

Figure 2.

## INSTALLATION

### ATTACH THE SPIDER TO THE FORK

1. Using two hands carefully place two Clamp Straps (8) on the fork tube. Use caution not to scratch the fork.
2. Refer to **Note below figure 3** and Hook the Spider (9) to the lower Clamp Strap. **Figure 3.**
3. Install the upper Clamp Strap.
4. Position the Mounting Cup (1) onto the Spider Bracket so the studs protrude from the holes in the Mounting Cup. **Figure 1, Page 1.**
5. Place a Brass Washer (7) onto the top stud. **Figure 1.**
6. Push the large Upper Nut (2) into the large Upper Spool (4) so the **thin side** of the spool is near the head of the Upper Nut. **Figure 1.**
7. Start the Upper Nut/Spool onto the upper stud. (**5/32" Hex Key**)
8. Assemble the Lower Spool (5) and Lower Nut (3) so the **thin side** of the Spool is near the head of the Lower Nut.
9. Start the Lower Nut/Spool onto the lower stud. (**5/32" Hex Key**)
10. Repeat steps 1 through 9 on the other fork.

### ALIGN SWITCHBLADE MOUNT ASSEMBLY

11. Adjust bottom edge of Mount Cup to be 1/4" (6.4mm) from the lower triple clamp. **See Figure 4.**



Depending on the motorcycle this may vary. Adjust clamp assembly so the shield clears the headlight when you install or remove the windshield.

12. Adjust both Mounting Cups front to rear so they are in line across the forks.



**Misalignment can cause damage to fuel tank and will cause the system to not work properly. Check alignment carefully. Turn the fork carefully to the stops. Make sure the gap between the Spools and the fuel tank are the same on both sides.**

13. Tighten the Nuts to 75 INCH POUNDS (8.6 Nm) (6.25 ft-lbs). **Figure 5. (Torque Wrench, 5/32" Hex Wrench.)**



This assembly will not "feel" like tightening a normal nut and bolt. Tightening from 25 in-lbs to 50 in-lbs will take at least one full turn.

14. To install the windshield refer to the booklet packaged with the SwitchBlade windshield. Install the shield. Make sure all components line up.



15. Cycle the shield through the mount and dismount 5 times. Retighten the Nuts to 75 INCH POUNDS (8.6 Nm) (6.25 ft-lbs).



Figure 5.



Figure 3.



#### Note:

- Engage the inside of the strap to the spider. Be sure spider hook is fully and correctly seated into the slot.
- a. The technique requires you to keep the hook of the spider correctly engaged in the slot. To do this, apply pressure on the inside engaged strap with your index finger while lifting the spider slightly with your middle finger.
  - b. Engage strap to hook of spider on outside. Push and stretch with your thumbs, don't let the inside hook/slot become loose.

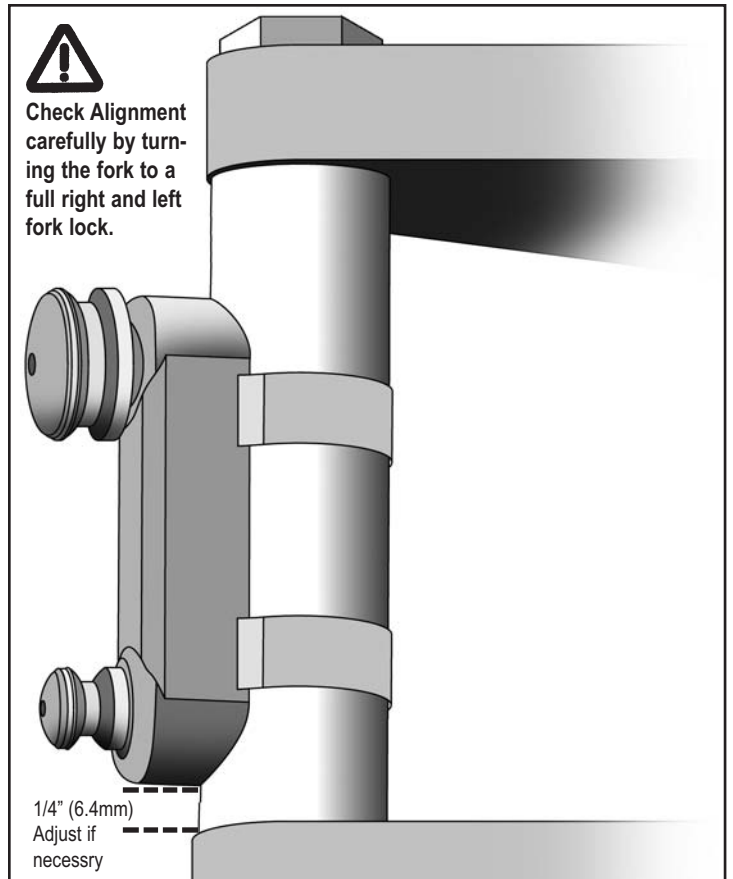

Figure 4.

### Parts List for Kit Q142

<u>INDEX</u>	<u>DESCRIPTION</u>	<u>QTY.</u>	
1	37-379102-000	Mounting Cup, Chrome	2
<b>BAG 671</b>			
2	34-340504-000	Nut, Upper, HD,SB, Polished	2
3	34-340502-000	Nut, Lower, HD,SB, Polished	2
4	34-340517-000	Spool, Upper, HD,SB	2
5	34-340512-000	Spool, Lower, HD,SB	2
6	44-441903-000	Cushion, HD,SB <b>(Figure 2)</b>	2
7	49-490414-000	Washer, Brass	2
<b>BAG 665</b>			
8	37-370184-000	Clamp Strap	4
9	37-370160-TL0	Spider, w/ Thread Locker	2

### Parts List for Kit Q143

<u>INDEX</u>	<u>DESCRIPTION</u>	<u>QTY.</u>	
1	37-379105-000	Mounting Cup, Chrome	2
<b>BAG 671</b>			
2	34-340504-000	Nut, Upper, HD,SB, Polished	2
3	34-340502-000	Nut, Lower, HD,SB, Polished	2
4	34-340517-000	Spool, Upper, HD,SB	2
5	34-340512-000	Spool, Lower, HD,SB	2
6	44-441903-000	Cushion, HD,SB <b>(Figure 2)</b>	2
7	49-490414-000	Washer, Brass	2
<b>BAG 824</b>			
8	37-370185-000	Clamp Strap	4
9	37-370161-TL0	Spider, w/ Thread Locker	2

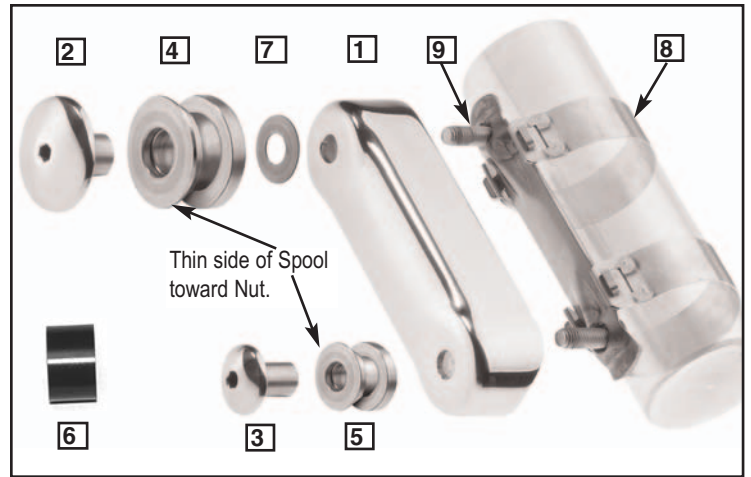

Figure 1