



INSTALLATION INSTRUCTION Hardware Mount KIT-JL and Hardware Mount KIT-JM

Mount Kit to install a Heavy Duty
or Dakota 4.5 Windshield to Suzuki C50

Thank you for purchasing a National Cycle product. Read these instructions carefully and thoroughly before beginning work. Dealers, if installing this windshield for a customer, please give them this manual upon completion. It contains information needed to properly maintain and use this product.



Attention:

Special notes and cautionary measures which can prevent damage to the accessory or motorcycle.



Note:

Tips for facilitation of operation, control and adjustment, as well as maintenance work.

CONTENTS OF KIT-JL

Item	Description	Part No.	Qty.
BAG#901			
1	Screw, Button Head M6 x12	51-516312-000	6
2	Nut, Hex	42-483002-000	6
3	Screw, Button Head M8x35	51-516435-000	4
4	Nut, M8-1.25	42-433030-000	4
5	Bracket	37-410504-000	2
6	Spacer	49-495560-000	4
CLAMPS			
7	Left Side Female (Slotted)	37-370031-000	1
8	Left Side Male (Tabbed)	37-370034-000	1
9	Right Side Female (Slotted)	37-370038-000	110
10	Left Side Male (Tabbed)	37-370039-000	1
RUBBER CLAMP SPACERS			
11	Large, 3/64 Thick	75-764701-000	4

TOOLS REQUIRED

Hex Key, 5/32"
Two 7/16" Wrenches
Scissor or Small Knife
Phillips Screw Driver
(to adjust window if necessary)

Right and Left are determined from a rider's perspective

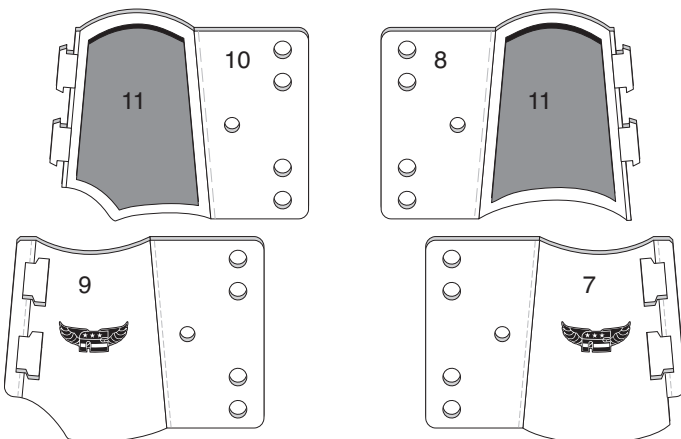

Diagram A, RIGHT SIDE

LEFT SIDE

CONTENTS OF KIT-JM

Item	Description	Part No.	Qty.
BAG#910			
1	Screw, Button Head M6 x12	51-516312-000	6
2	Nut, Hex	42-483002-000	6
3a	Screw, Button Head M8x60	51-516461-000	4
4	Nut, M8-1.25	42-433030-000	4
5	Bracket	37-410504-000	2
BAG#012			
6a	Spacer, 1.61 Length	49-495564-000	4
CLAMPS			
7	Left Side Female (Slotted)	37-370031-000	1
8	Left Side Male (Tabbed)	37-370034-000	1
9	Right Side Female (Slotted)	37-370038-000	1
10	Left Side Male (Tabbed)	37-370039-000	1
RUBBER CLAMP SPACERS			
11	Large, 3/64 Thick	75-764701-000	4

PREPARATION

Take precaution against paint damage while installing your windshield kit to your motorcycle. Place a heavy cloth over the front fender of your motorcycle to prevent any scratches or dents from occurring should a tool or part fall during installation.

INSTALLATION

1. Install die cut Rubber Clamp Spacers to each clamp half.

Trim the Spacer at the inside edge of Right Side Male and Female Clamp. (Scissor) Diagram A.

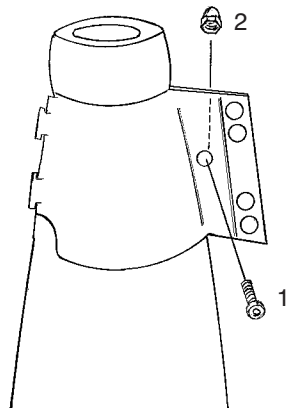

Diagram B, RIGHT SIDE

2. Put Clamps on fork.

A. Must hit upper triple clamp.

B. Use M6 x 12 Screw and Acorn nut to clamp together. Tighten to 10 ft. lbs. Diagram B. (Hex Key, Wrenches)

3. Install windshield onto brackets using chrome spacers and flat plate, as shown in diagram C. (Hex Key, Wrenches)

4. Make final adjustments. Check symmetry of left and right sides and clearance. Gently turn handlebar left and right to full fork lock to assure that no interference occurs between the Hardware, turnsignals or Chrome Lower and the gas tank.

5. Fully tighten socket head screws, bolts, and cap nuts.

Optional adjustment of the window. For Heavy Duty™ Windshields only.

The adjustable window is easily adjusted or changed in all National Cycle Heavy Duty Windshields. Loosen the 6 cap nuts on the vertical chrome strips. Replace or adjust the window. Tighten cap nuts to 2 - 4 ft. lbs. (2.7 - 5.4 Nm), torque pressure.

CLEANING AND MAINTENANCE

To clean the screen, wash with a clean soft cloth and plenty of warm water and, if necessary, a non-abrasive soap such as dishwashing liquid. Flannel or soft chamois make good cleaning cloths. **Paint, glue residue or grease removal:** Moisten cotton wad with naphtha or turpentine followed by a wash as above.

National Cycle **Shield Wash™** (N1401-01) makes a good daily cleaner and comes with a handy travel-size bottle. Shield Wash is safe for all windshields and helmet visors.

Do not clean polycarbonate in hot sun or high temperatures. Do not clean the screen with household glass cleaners.

Do not allow brake fluid, alcohol, or strong solvents to contact the screen.

RAIN REPELLENT

Do not use rain protective products made for glass. We recommend National Cycle's **RainZip®** (N1410-01) to keep your windscreen clear in rainy weather.

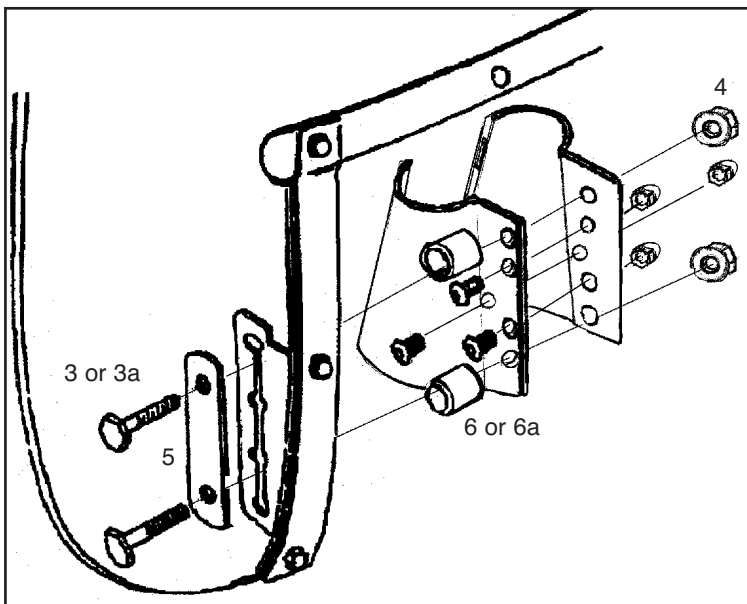

Diagram C

