

**Installation of Spacers and Clamps**

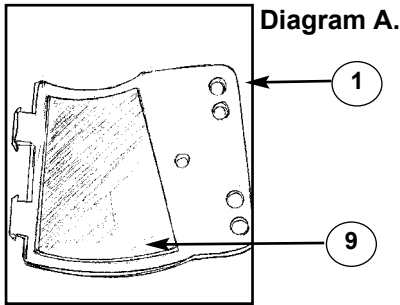

**Diagram A.**

**1.** Install die cut Rubber Clamp Spacers to each clamp half. Diagram A.

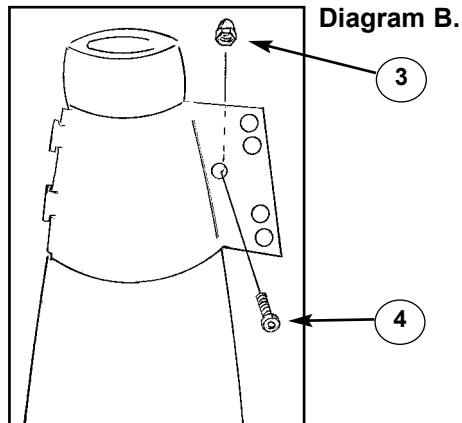

**Diagram B.**

**2.** Put Clamps on fork.  
 A. Must hit upper triple clamp.  
 B. Use M6 x 12 Screw and Acorn nut to clamp together. Tighten to 10 ft. lbs.  
 Diagram B.

**Note: 2a. instruction is for installation of National Cycle Chrome Lowers (optional.)**

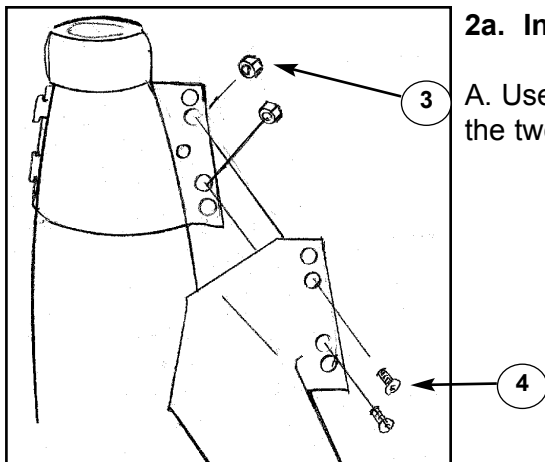

**2a. Instruction for Chrome Lower installation.**

A. Use the M6 x 12 Screws and Acorn Nuts thru the two inner holes. Tighten to 10ft. lbs.

**Installation of Windshield**

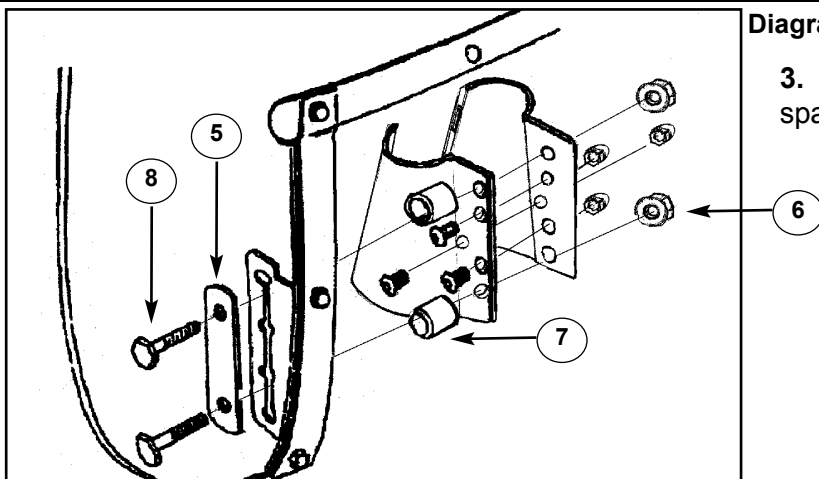

**Diagram C.**

**3.** Install windshield onto brackets using chrome spacers and flat plate, as shown in diagram C.

## Make Final Adjustments. Check Clearance.

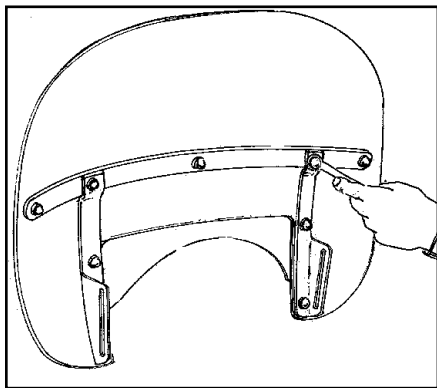

Diagram D.

4. Make final adjustments. Check symmetry of left and right sides and clearance. Gently turn handlebar left and right to full fork lock to assure that no interference occurs between the Hardware, turnsignals or Chrome Lowers and the gas tank. **Fully tighten** socket head screws, bolts, and cap nuts.

### **Optional adjustment of the window.**

#### **For Heavy Duty™ Windshields only.**

The adjustable window is easily adjusted or changed in all National Cycle Heavy Duty Windshields. Loosen the 6 cap nuts on the vertical chrome strips. Replace or adjust the window. Tighten cap nuts to 2 - 4 ft. lbs. (2.7 - 5.4 Nm), torque pressure.

## Warning / Caution / Maintenance

**WARNING** National Cycle windshields and fairings are designed to provide wind protection and increased riding comfort, but not protection in the event of a collision with another vehicle, the road, birds, or any other object.

Our products utilize certain features, patented and otherwise, that may minimize injury in certain accidents, but the possibility of injury exists if the screen is broken or if impacted by an object. Always wear eye protection, helmets and protective clothing. Never ride your motorcycle while under the influence of drugs or alcohol.

All of our products are made in conformance and exceed the requirements of D.O.T. SS205,Z26.1, classifications AS6 and AS7, which covers all safety glazing for motorcycle application. Never ride your motorcycle with loose windshield mounting hardware. Check the hardware for tightness regularly.

Today's motorcycles are built with enough frame rigidity to withstand the moderate loads imposed on them by the foreseeable addition of a fork mounted windshield. If the addition of an accessory(ies) adversely affects your motorcycle's stability, immediately remove the accessory(ies). Do not ride a motorcycle that exhibits unsafe handling traits.

Have experienced service personnel correct any problem before riding with the accessory(ies) installed. For further questions concerning handling problems associated with an accessory(ies), contact your dealer, motorcycle manufacturer, or accessory manufacturer.

**MAINTENANCE** To clean the screen, wash with a clean soft cloth, plenty of warm water and, if necessary, a non-abrasive soap such as dishwashing liquid. Flannel or soft chamois make good cleaning cloths. Paint, glue residue or grease removal: Moisten cotton with Naphtha or Turpentine followed by a wash as above. Apply a high quality plastic cleaner, such as McGuiar's Mirror-Glaze MG-17 or Novus #2, to the screen. This will leave a protective coating in the screen making future cleanings easier. Do not clean polycarbonate in hot sun or high temperatures.

Do not clean the screen with glass cleaners. Do not use rain protective products on the screen. The solvent action of the alcohol in these products will destroy the screen. Do not allow brake fluid, alcohol, or strong solvents to contact the screen or penetrate between the chrome brackets and the Permanent damage will result! To remove fine scratches, use a very soft clean cloth and a fine grade buffing compound. Jewelers rouge or McGuiar's Mirror-Glaze MG-10 are best for this type of buffing. We recommend hand buffing.

**STORAGE** Do not use low quality vinyl covers or old shower curtains to store your motorcycle or windshield. These products damage the plastic of windshields and the motorcycle body.

## PARTS LIST FOR KITS JA and JB

CHROME HARDWARE KIT	BAG # 725	BAG # 903											
JA	1												
JB		1											

No.	Part No.	Description	Qty.
-----	----------	-------------	------

### Bag 725

5	37-410504	Flat Bracket	2
6	42-433030	Whizlok Nut M8-1.25	4
7	49-495531	Spacer Chrome .625 Long	4
8	51-516435	Screw, Button M8x 35	4
9	75-764701	Rubber Spacer	4

### Bag 903

1	37-370030	Clamp Taper with Tabs	2
2	37-370031	Clamp Taper with Slots	2
3	42-483002	Acorn Hex Nut	6
4	51-516312	Screw, Button M6x 12	6
5	37-410504	Flat Bracket	2
6	42-433030	Whizlok Nut M8-1.25	4
7	49-495565	Spacer Chrome 1.81 Long	4
8	51-516450	Screw, Button M8-1.25 x 65	4
9	75-764701	Rubber Spacer	4

**INSTALLING MECHANICS:** Pass instruction manual onto customer. This contains vital information about the use, adjustments, and maintenance of the product. It also contains important cautionary and warning information. Please take the time to become familiar with your chrome hardware kit and **HEAVY DUTY™** or **DAKOTA™** WINDSHIELD to obtain the best results in use.



Hex Key, 5/32"  
Two 7/16" Wrenches  
and a Phillips screw driver to  
adjust window if desired.