



national cycle

**CUSTOM HEAVY DUTY (N2220) and RANGER HEAVY DUTY (N2290)
OWNER'S MANUAL and ASSEMBLY INSTRUCTIONS**

**PARTS LIST FOR HARDWARE KIT HA (37.1 - 41 mm FORK CLAMP)
AND KIT HB (37mm FORKS OR LESS)**

BAG NO. 182

<u>Index No.</u>	<u>Part No.</u>	<u>Description</u>	<u>Qty.</u>
1	34-350201-000	Frame Brkt. Offset Right	1
2	34-350301-000	Frame Brkt. Offset Left	1
3	42-431000-000	Nut, 5/16-24 Whizlok	4
4	49-490300-000	Washer, 5/16 ID	4
5	50-503200-000	Bolt, 5/16-24 x 1" Hex	4
6	49-495800-000	Bushing, .5 Length	4
7	49-495500-000	Bushing, .2 Length	4

HARDWARE KIT HA CONTAINS:

<u>QTY.</u>	<u>BAG NO.</u>
1	BAG 182
1	BAG 165

HARDWARE KIT HB CONTAINS:

<u>QTY.</u>	<u>BAG NO.</u>
1	BAG 182
1	BAG 166

BAG NO. 165

<u>Index No.</u>	<u>Part No.</u>	<u>Description</u>	<u>Qty.</u>
8	37-400740-000	"R" Clamp 41mm	4
9	75-764000-000	Rubber Spacer	8
10	49-490520-000	Washer, 1/4"	4
11	51-518030-000	Screw, 1/4-20 x 1" Button	4
12	59-515110-000	Key, 5/32" Short Arm	1

BAG NO. 166

<u>Index No.</u>	<u>Part No.</u>	<u>Description</u>	<u>Qty.</u>
8	37-400750-000	"R" Clamp 37mm	4
9	75-764000-000	Rubber Spacer	8
10	49-490520-000	Washer, 1/4"	4
11	51-518030-000	Screw, 1/4-20 x 1" Button	4
12	59-515110-000	Key, 5/32" Short Arm	1

IMPORTANT: Please report any missing parts to your dealer. The following information is necessary:

**BAG NO. and
6 DIGIT SERIAL NO.**

This information is located on the outside
of each plastic bag contained in the kit.

PRECAUTIONS

National Cycle windshields and fairings are designed to provide wind protection and increased riding comfort but not protection in the event of a collision with another vehicle, the road, or any other object.

Our products utilize certain features, patented and otherwise, that may minimize injury in certain accidents, but the possibility of injury still exists.

All of our products are made in conformance and exceed the requirements of U.O.I. SS205, 226.1, classifications AS6 and AS7, which covers all safety glazing for motorcycle application.

WARNING

Never ride your motorcycle with loose or missing windshield mounting hardware. Check the hardware for tightness regularly.

Today's motorcycles are built with enough frame rigidity to withstand the moderate loads imposed on them by the foreseeable addition of a fork mounted fairing.

If the addition of an accessory(ies) adversely affects your motorcycle's stability, immediately remove the accessory(ies). Do not ride a motorcycle that exhibits unsafe handling traits. Have experienced service personnel correct any problem before riding with the accessory(ies) installed. For further questions concerning handling problems associated with an accessory(ies), contact your dealer, motorcycle manufacturer, or accessory manufacturer.

Sunlight reflected off the inside curvature of the fairing can, at certain times of the day, cause extreme heat buildup on the motorcycle's instruments and possibly even melt them. Exercise care in parking to avoid this. Park facing the sun or place an opaque object over this area.

CARE AND CLEANING

Your windshield is made of prime G.E. Lexan® FMR polycarbonate sheet. Always pre-rinse screen with water to remove grit and soften dirt. Wash with mild liquid soap, lots of warm water, and a clean soft cloth or sponge. Rinse well to remove all soap residue. Dry with a chamois, flannel or moist sponge to prevent water spots. Paint, grease; Use a cotton ball moistened with turpentine, follow with wash as described above. This also works on label residue.

If a hairline scratch or abrasion occurs on your windshield it can be minimized with a non-silicone polish. The polish will make cleaning easier. These products tend to polish and fill scratches, making them invisible; Mequiar's Mirror Glaze, Simonize Wax, Johnson's Paste Wax.

PRIOR TO INSTALLING WINDSHIELD- CHECK HEIGHT, ADJUST WINDOW IF DESIRED

1. The window area of the N2220 and N2290 is adjustable. The amount of adjustment you can obtain is determined by the location of the windshield vertical brackets to the motorcycle fork tubes. The product is shipped with screen in its lowest position.

Adjustment to the window can be made at any time, although it is easier when the windshield is off the motorcycle. When window is adjusted to its lowest position, the screen height is in its highest position. The result is the windshield vertical brackets will align higher on the fork tube of the motorcycle. **BE CAREFUL NOT TO ADJUST VERTICAL BRACKETS OUT OF THE RANGE NECESSARY TO MOUNT SHIELD TO THE FORKS.**

While sitting on the motorcycle, hold windshield to headlight. This will be easier if you have a friend to help you. Determine if you would like screen adjusted higher. Refer to below diagram and **LOOSEN** the 6 Philip head screws on the vertical strips. Firmly grasp window and pull down the desired amount. There is about 2 1/2" of possible adjustment, and depending on alignment of the windshield vertical brackets to the motorcycle fork tubes, this may be limited. **Retighten the 6 Philip head screws snug, but gently.**

DO NOT OVER TIGHTEN

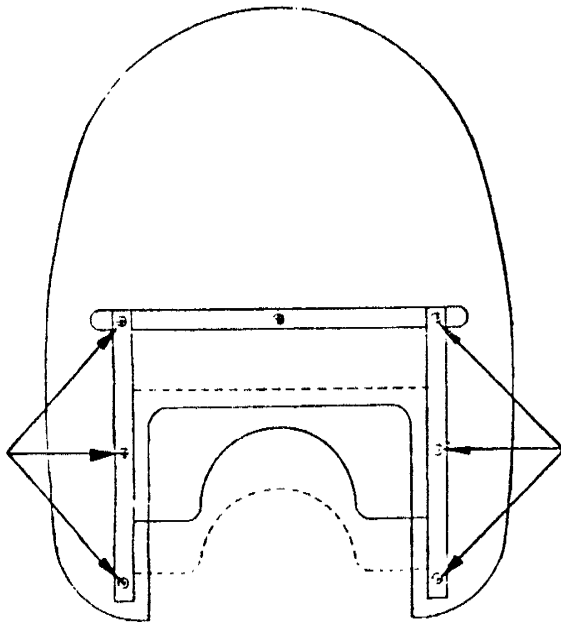

**RETIGHTEN SNUG, BUT GENTLY!
DO NOT OVERTIGHTEN!**

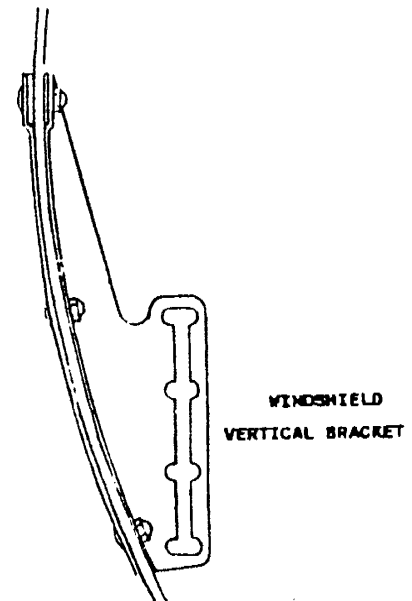

DETERMINE PLACEMENT OF OFFSET BRACKET TO WINDSHIELD AND POSITION OF "R" CLAMPS TO FORK.

2. Use a 1" bolt, washer and Whizlok nut to **LOOSELY** install the offset bracket to the windshield vertical bracket. **NOTE: THE OFFSET BRACKET CAN BE POSITIONED WITH WIDER END TO BOTTOM AS IN DIAGRAM 2, OR INVERTED. PROCEED AS IN DIAGRAM, AND MAKE ADJUSTMENTS ACCORDING TO YOUR MOTORCYCLE. DO NOT INSERT BUSHINGS AT THIS TIME.**

ON SUZUKI INTRUDERS, AND A FEW OTHER MOTORCYCLES, THE OFFSET BRACKET IS NOT NECESSARY TO INSTALLATION. PROCEED WITH INSTALLATION OF "R" CLAMP TO FORK TUBE AND ATTACH WINDSHIELD VERTICAL BRACKET DIRECTLY TO "R" CLAMP.

Hold windshield over headlight with window just above headlight. Mark where **HOLE**s in offset bracket line up on fork tube. This is where you will install the "R" clamps. **AT THIS POINT FURTHER ADJUSTMENT CAN BE MADE BY SLIDING THE OFFSET BRACKET UP OR DOWN ON THE WINDSHIELD VERTICAL BRACKET.**

IF NECESSARY, REPOSITION TURN SIGNALS

3. Some applications may require the repositioning of the turn signals. Refer to your motorcycle's owner's manual for removal of turn signals. Turn signals will be installed onto the offset bracket as shown below. Be careful not to crimp any wires. Test operation of turn signals before riding.

INSTALL "R" CLAMPS and IF NECESSARY RUBBER SPACER

4. Spring two "R" Clamps over each fork with **FLAT SURFACE OF CLAMP** to the outside of fork. as shown below. Use a pliers to squeeze the "R" clamp together around fork tube. If there is slack in the "R" clamp place one piece of rubber spacer inside clamp. Test clamp for tightness, if necessary place an additional rubber spacer inside clamp.

INSTALL OFFSET BRACKET TO "R" CLAMP

5. To ease installation of the offset bracket to the "R" clamp remove the offset bracket from the windshield. Preassemble a flat washer on an Allen head screw and insert into the hole of the offset bracket. Squeeze the "R" clamp shut with a pliers and thread the screw assembly into the "R" clamp. **DO NOT FULLY TIGHTEN UNTIL ALL ADJUSTEMENTS ARE MADE.**

DETERMINE PROPER SPACING FOR INSTALLATION OF WINDSHIELD

6. Hold the windshield centered on the headlight with vertical brackets lined up with holes in offset bracket. Check to see if the addition of the .5 and, or .2 bushings are necessary to fill up the remaining space between windshield bracket and offset bracket.

FINAL INSTALLATION OF WINDSHIELD TO OFFSET BRACKET

7. Assemble one 5/16" ID flat washer over bolt. Insert bolt assembly through windshield vertical bracket, place required bushings on bolt, and insert through hole in offset bracket. **HAND TIGHTEN** with Whizlok nut.

FINAL ADJUSTMENT

8. Check windshield for desired height above headlight and desired angle. Make necessary adjustments. **FIRMLY TIGHTEN ALL HARDWARE IN THE FOLLOWING ORDER:** Hex bolts and Whizlok nuts and then Allen head screws into "R" clamps.

Diagram 2.

