

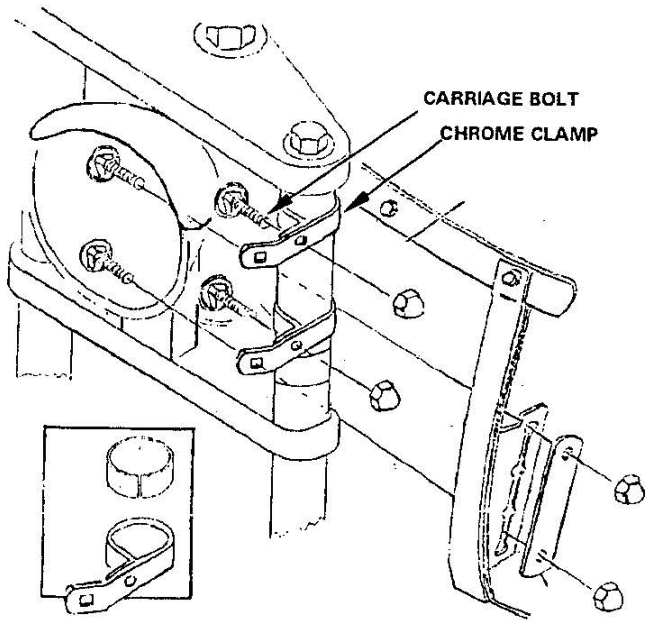

**CRUISER WINDSHIELD
OWNER'S MANUAL**

N2281 KIT CTE	N2282 KIT CTF
N2283 KIT CTG	N2284 KIT CTH
N2285 KIT CTI	N2286 KIT CTJ



PARTS LIST FOR KITS: CTE, CTF, CTG, CTH, CTI, CTJ,

Bag No. 111 (used in all kits)		
Part No.	Description	Qty.
37-410507	FLAT BRACKET	2
55-586040	CARRIAGE BOLT	8
42-482200	CAP NUT	8
Bag No.040 (Kit CTE)		
37-400922	CHROME CLAMPS	4
75-764001	CLAMP SPACER	4
Bag No.039 (Kit CTF)		
37-400920	CHROME CLAMPS	4
75-764001	CLAMP SPACER	4
75-764002	CLAMP SPACER	4
Bag No.037 (Kit CTG)		
37-400200	CHROME CLAMPS	4
75-764001	CLAMP SPACER	4
Bag No.044 (Kit CTH)		
37-400950	CHROME CLAMPS	4
75-764001	CLAMP SPACER	4
Bag No.041 (Kit CTI)		
37-400924	CHROME CLAMPS	4
75-764001	CLAMP SPACER	4
Bag No.043 (Kit CTJ)		
37-400940	CHROME CLAMPS	4
75-764001	CLAMP SPACER	4

INSTALLING MECHANICS:

Pass instruction manual onto customer. This contains vital information about the use, adjustments, and maintenance of the product. It also contains important cautionary and warning information. This manual is designed for complete product knowledge; parts identification, installation, precautions, and maintenance.

INSTALLATION PROCEDURE

1. Slightly ease open a fork bracket just enough to slip it onto the fork. Apply one strip of rubber gasket to inside of fork clamp. Trim gasket if necessary. Repeat for other 3 clamps. Slip fork clamps onto fork tubes with long side of clamp facing outward, and forward as illustrated in diagram.

POSITION CLAMPS

2. Determine position of clamps by holding windshield in place approximately 10mm (1/2") to 20mm (1") over headlight. Hand tighten clamps into position. Insert carriage bolts through holes from inside of fork and hand tighten with cap nuts.

POSITION WINDSHIELD

3. Hold windshield in place so that top of headlight opening is approximately 10mm (1/2") to 20mm (1") over headlight. Adjust the chrome fork clamps to correct location using flat bracket and windshield as reference. Install windshield onto brackets using flat plate, remaining carriage bolts, and cap nuts.

4. Make final adjustments. Check symmetry of left and right sides. Fully tighten all 8 carriage bolts, and cap nuts.

WARNING

National Cycle windshields and fairings are designed to provide wind protection and increased riding comfort, but not protection in the event of a collision with another vehicle, the road, birds, or any other object.

Our products utilize certain features, patented and otherwise, that may minimize injury in certain accidents, but the possibility of injury exists if the screen is broken or if impacted by an object. Always wear eye protection, helmets and protective clothing. Never ride your motorcycle while under the influence of drugs or alcohol.

All of our products are made in conformance and exceed the requirements of DOT SS205, Z26.1, classifications AS6 and AS7, which covers all safety glazing for motorcycle application.

Never ride your motorcycle with loose windshield mounting hardware. Check the hardware for tightness regularly.

Today's motorcycles are built with enough frame rigidity to withstand the moderate loads imposed on them by the foreseeable addition of a fork mounted windshield.

If the addition of an accessory(ies) adversely affects your motorcycle's stability, immediately remove the accessory(ies). Do not ride a motorcycle that exhibits unsafe handling traits.

Have experienced service personnel correct any problem before riding with the accessory(ies) installed. For further questions concerning handling problems associated with an accessory(ies), contact your dealer, motorcycle manufacturer, or accessory manufacturer.

MAINTENANCE

To clean the screen, wash with a clean soft cloth, plenty of warm water and, if necessary, a non-abrasive soap such as dishwashing liquid. Flannel or soft chamois make good cleaning cloths. Paint, glue residue or grease removal: Moisten cotton with Naphtha or Turpentine followed by a wash as above. Apply a high quality plastic cleaner, such as McGuir's Mirror-Glaze MG-17 or Novus #2, to the screen. This will leave a protective coating in the screen making future cleanings easier. Do not clean polycarbonate in hot sun or high temperatures.

Do not clean the screen with glass cleaners. Do not use rain protective products on the screen. The solvent action of the alcohol in these products will destroy the screen. Do not allow brake fluid, alcohol, or strong solvents to contact the screen or penetrate between the chrome brackets and the polycarbonate. Permanent damage will result! To remove fine scratches, use a very soft clean cloth and a fine grade buffing compound. Jewelers rouge or McGuir's Mirror-Glaze MG-10 are best for this type of buffing. We recommend hand buffing.

STORAGE

Do not use low quality vinyl covers or old shower curtains to store your motorcycle or windshield. These products damage the plastic of windshields and the motorcycle body.

TRIMMING

All National Cycle accessory and replacement windscreens are top quality wind protection devices. Proper care can help these windscreens give many years of motorcycling enjoyment.

Because each rider has their own combination of physical height and /or motorcycle accessories, trimming may become necessary for the best installation. National Cycle Heavy Duty products are made from polycarbonate and can be trimmed if a few simple procedures are followed. I'm sorry, we cannot be responsible for damage to the product which occurs during trimming.

NOTE: Use of jig saw or saber saw is not recommended! If the windscreen is to be shortened from the top, remember to choose the new height while seated on the motorcycle (both wheels on the ground), with it normally loaded. In all cases you should be able to see over the top of the screen at least by stretching, in case the screen should become opaque because of rain or dirt.

Too much should not be taken off the top as this will affect how far the air shoots off the top of the screen. The rake angle of the screen, which is adjustable in most applications, will also affect how the air comes off the screen.

Mark the line to be cut with a crayon or china marker; these can be easily washed off. A ruler or piece of paper can be used as a guide to duplicate the original shape.

Secure the windshield by gripping it with your knees. This leaves both hands free for filing or sanding. The trimming should be done by sanding or filing with a coarse 60-80 grit file. Since shudders, jolts, and sudden shocks can promote cracking, a smooth continuous motion should be used. A flat belt sander will remove material quickly, but keep the sander moving back and forth for a smooth edge.

If a large amount of trimming is required, a band saw can be used safely. Protect the screen with masking tape before cutting. The blade should have about ten teeth per inch. A hack saw will also work well; be careful not to let it bind in the cut.

Once the desired shape is found, use the coarse file or sandpaper to round the edges. Any scratches that result from handling can be removed. Refer to the Maintenance instructions.