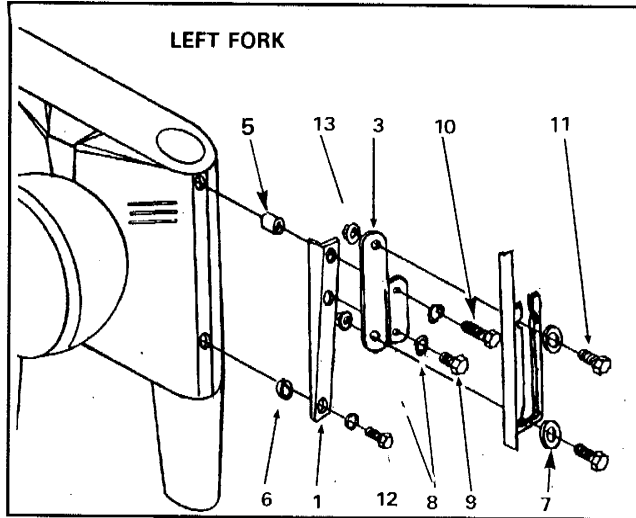
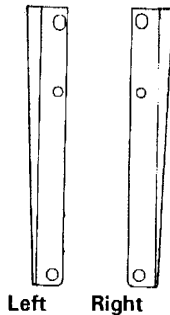
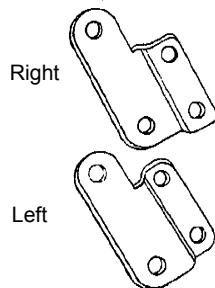
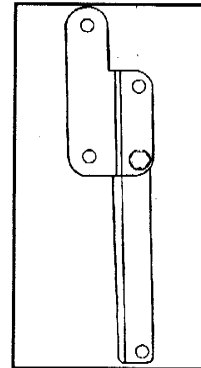
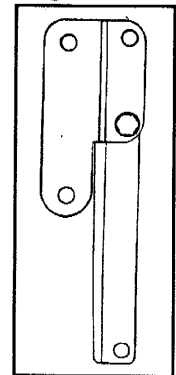

Diagram A

Diagram B
Vertical Brackets

Offset Brackets

Diagram C

Position A.
Diagram D

Position B.
INSTALLING MECHANICS:

Pass instruction manual onto customer. This contains vital information about the use, adjustments, and maintenance of the product. It also contains important cautionary and warning information.

This manual is designed for complete product knowledge; parts identification, installation, precautions, and maintenance. Please take the time to become familiar with your KIT CHQ and HEAVY DUTY WINDSHIELD to obtain the best results in use.

INSTALLATION PROCEDURE

IMPORTANT: Left and right side of motorcycle is determined from riding position.

1. Install offset brackets to vertical fork brackets.

NOTE: You can choose between two windshield mounting positions. Refer to diagram B to identify left and right offset and vertical brackets before proceeding.

Position A. To position the windshield for maximum height, install the **left** offset bracket to the **left** vertical fork bracket at the middle hole using a 1/2" hex head bolt and a split washer as shown in diagram C. Repeat for the right side with right offset bracket and right vertical fork bracket.

Position B. To position the windshield for lowest possible height, install the **right** offset bracket to the **left** vertical fork bracket at the middle hole using a 1/2" hex head bolt and a split washer as shown in diagram D. Repeat for the right side with left offset bracket and right vertical fork bracket.

2. Remove screws from side of motorcycle fork cover. Use the supplied 1" bolt (at top location) and 3/4" bolt to attach the vertical fork bracket to the appropriate fork tube as indicated in diagram A.

3. Mount shield to the offset bracket using the remaining 5/8" hex head bolts, flat washers, and whizlock nuts. Refer to diagram A. **Note:** At this time check height of windshield. The higher you raise the windshield, the lower you will adjust the window. Refer to back of sheet.

4. Make final adjustments. Check symmetry of left and right sides. Fully tighten all hex head bolts.

PARTS LIST
Loose in Kit

Index No.	Part No.	Description	Qty.
1	34-350205-000	Left Vertical Fork Bracket	1
2	34-350305-000	Right Vertical Fork Bracket	1
3	34-350505-000	Left Offset Bracket	1
4	34-350405-000	Right Offset Bracket	1

BAG NO. 14

5	49-495600-000	.5 Bushing	2
6	49-495500-000	.2 Bushing	2
7	49-490330-000	Flat Washer	4
8	49-491300-000	Split Washer	6
9	50-503000-000	Hex Bolt 5/16-24x1/2"	2
10	50-503200-000	Hex Bolt 5/16-24x1"	2
11	50-503500-000	Hex Bolt 5/16-24x5/8"	4
12	50-503600-000	Hex Bolt 5/16-24x3/4"	2
13	42-431000-000	Whizlock Nut 5/16-24	4

TOOL LIST:

Two 1/2" wrenches. To adjust window if desired: 1, 7/16" wrench and a Phillips screwdriver.

WARNING

National Cycle windshields and fairings are designed to provide wind protection and increased riding comfort, but not protection in the event of a collision with another vehicle, the road, birds, or any other object.

Our products utilize certain features, patented and otherwise, that may minimize injury in certain accidents, but the possibility of injury exists if the screen is broken or if impacted by an object.

Always wear eye protection, helmets and protective clothing. Never ride your motorcycle while under the influence of drugs or alcohol.

All of our products are made in conformance and exceed the requirements of D.O.T. SS205.226.1, classifications AS6 and AS7, which covers all safety glazing for motorcycle application.

Never ride your motorcycle with loose windshield mounting hardware. Check the hardware for tightness regularly.

Today's motorcycles are built with enough frame rigidity to withstand the moderate loads imposed on them by the foreseeable addition of a fork mounted windshield.

If the addition of an accessory(ies) adversely affects your motorcycle's stability, immediately remove the accessory(ies). Do not ride a motorcycle that exhibits unsafe handling traits. Have experienced service personnel correct any problem before riding with the accessory(ies) installed. For further questions concerning handling problems associated with an accessory(ies), contact your dealer, motorcycle manufacturer, or accessory manufacturer.

MAINTENANCE

To clean the screen, wash with a clean soft cloth, plenty of warm water and, if necessary, a non-abrasive soap such as dishwashing liquid. Flannel or soft chamois make good cleaning cloths. Paint, glue residue or grease removal: Moisten cotton with Naptha or Turpentine followed by a wash as above.

Apply a high quality plastic polish, such as McGuir's Mirror-Glaze MGH-17 or Novus #2, to the clean screen. This will leave a protective coating in the screen making future cleanings easier. Do not clean polycarbonate in hot sun or high temperatures.

Do not clean the screen with glass cleaners. Do not use rain protective products on the screen. The solvent action of the alcohol in these products will destroy the screen. Do not allow brake fluid, alcohol, or strong solvents to contact the screen or penetrate between the chrome brackets and the polycarbonate. Permanent damage will result!

To remove scratches, use a very soft clean cloth and a fine grade buffing compound. Jewelers rouge or McGuir's Mirror-Glaze MGH-10 are best for this type of buffing. We recommend hand buffing.

STORAGE

Do not use low quality vinyl covers or old shower curtains to store your motorcycle or windshield. These products damage the plastic of windshields and the motorcycle body.

PLEXIFAIRING 3, PLEXOSTAR 2, AIRHAWK, MIRAGE, DEFLECTOR SCREEN, STREET SHIELD AGRESSOR and other National Cycle wind protection products are covered by one or more of the following patent numbers: 4489973, 4379584, 4082345, 4168098

TRIMMING

All National Cycle accessory and replacement wind-screens are top quality wind protection devices. Proper care can help these windscreens give many years of motorcycling enjoyment.

Because each rider has their own combination of physical height and /or motorcycle accessories, trimming may become necessary for the best installation. National Cycle Heavy Duty products are made from polycarbonate and can be trimmed if a few simple procedures are followed. I'm sorry, we cannot be responsible for damage to the product which occurs during trimming.

NOTE: Use of jig saw or sabre saw is not recommended!

If the windscreen is to be shortened from the top, remember to choose the new height while seated on the motorcycle (both wheels on the ground), with it normally loaded. In all cases you should be able to see over the top of the screen at least by stretching, in case the screen should become opaque because of rain or dirt.

Too much should not be taken off the top as this will affect how far the air shoots off the top of the screen. The rake angle of the screen, which is adjustable in most applications, will also affect how the air comes off the screen.

Mark the line to be cut with a crayon or china marker; these can be easily washed off. A ruler or piece of paper can be used as a guide to duplicate the original shape.

Secure the windshield by gripping it with your knees. This leaves both hands free for filing or sanding.

The trimming should be done by sanding or filing with a coarse 60-80 grit file. Since shudders, jolts, and sudden shocks can promote cracking, a smooth continuous motion should be used. A flat belt sander will remove material quickly, but keep the sander moving back and forth for a smooth edge.

If a large amount of trimming is required, a band saw can be used safely. Protect the screen with masking tape before cutting. The blade should have about ten teeth per inch. A hack saw will also work well; be careful not to let it bind in the cut.

Once the desired shape is found, use the coarse file or sandpaper to round the edges. Any scratches that result from handling can be removed. Refer to the Maintenance instructions.

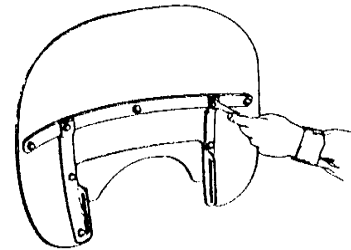

ADJUSTING AND CHANGING WINDOWS

The adjustable window is easily adjusted or changed in all National Cycle Heavy Duty windshields.

Loosen the 6 cap nuts on the vertical chrome strips. Replace or adjust window. Tighten cap nuts to 2-4 ft.lbs (2.7 - 5.4 Nm), torque pressure.

Shop for other windshields & fairings on our website.