

Index	Description	Qty.
1	Mount Bracket, Left	1
2	Mount Bracket, Right	1
3	Fork Clamp, Outer	1
4	Fork Clamp, Inner	1
5	Rubber Clamp Spacers	4
6	Spacer Bushings	2
7	Screws, Button Head, M8 x 35	2
8	Screw, M8 x 20 Hex Head	4
9	Washer Plate	2

PREPARATION

INSTALLING MECHANICS: Pass instruction manual onto customer. This contains vital information about the use, adjustments, and maintenance of the product. It also contains important cautionary and warning information.

Take precaution against paint damage while installing your windshield kit to your motorcycle. Place a heavy cloth over the front fender of your motorcycle to prevent any scratches or dents from occurring should a tool or part fall during installation.

MOUNT BRACKET INSTALLATION

Note: Bracket installation is best performed one side at a time.

1. Remove screws at the top, front, of the Fork Cover (5mm Hex Key Wrench). Set these screws aside for reuse. Diagram A.
2. Cut rubber Spacers: Two pieces 3" (7.6 cm) in length and 2 pieces 4.25" (10.5 cm) in length. Apply the Rubber Clamp Spacers to the inside surface of the four Fork Clamp halves. Diagram B.
3. Place right Mount Bracket so the hole in the upper flat aligns with the hole in the Fork Cover. Place a Spacer Bushing between the Mount Bracket and the Fork Cover. Loosely thread a M8 x 35 Button Head Screw through the Mount Bracket, the Spacer Bushing, and into the hole in the Fork Cover. Diagram C.
4. Wrap an Outer and Inner Fork Clamp, with Rubber Spacers installed, around the round Fork Cover about 1" (25mm) below the lower triple clamp.
5. Rotate the Mount Bracket so its lowest hole aligns with the Fork Clamp and thread a screw, from step 1, through the Mount Bracket and into the Fork Clamp's welded nut. Diagram D.
6. Repeat steps 1 through 5 on left side.
7. Tighten the four screws that hold the Mount Brackets to 3 m-kg (21 Ft Lbs)

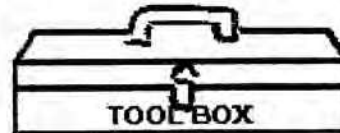

Tools used in all installations:

Hex Key Wrench 5mm

Wrench 13mm

Screwdriver, Phillips (to adjust window in Heavy Duty Windshields if necessary)

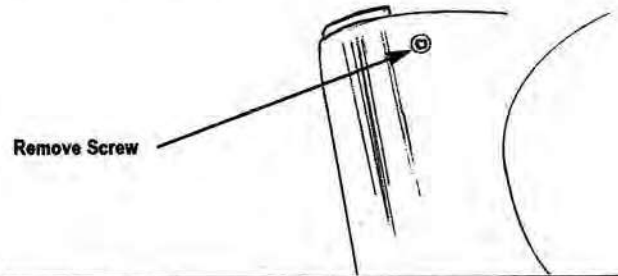

Diagram A.

Apply rubber Spacer to inside surface of the four clamp halves.

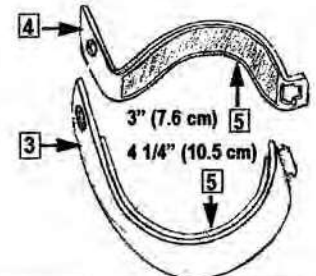

Diagram B.

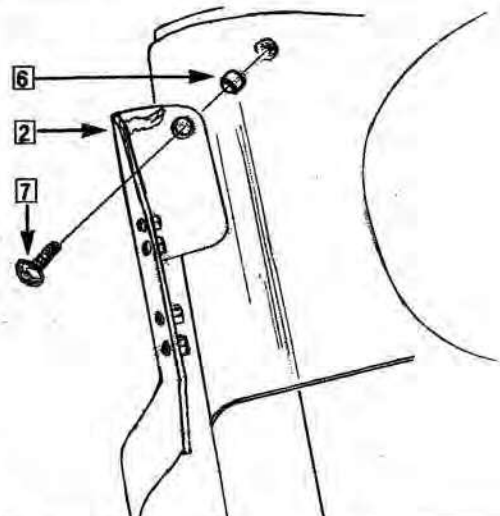

Diagram C.

WINDSHIELD INSTALLATION

1. Put one M8 x 20 Hex Head screw through a hole in each Washer Plate. Diagram E.

2. Hold Windshield in place at Mount Brackets.

Note: At this time check height of windshield. Two different sets of holes are provide for height adjustment. The higher you raise the windshield, the lower you will adjust the window. Refer to "Adjusting Window".

3. Thread Screw with Washer Plate, through Windshield Vertical Brackets, into nuts on fork mounted brackets, do this on each side of shield.

4. Repeat Step 3 for remaining M8 x 20 Hex Head screws.

5. Adjust location of windshield on Mount Brackets to desired height and angle.

6. Tighten M8 Hex Head Screws to 15 foot/pounds torque (13mm Wrench).

7. Adjust the Adjusting Window per provided instructions below, if needed.

ADJUSTING WINDOW

The window is easily adjusted. Loosen the 6 cap nuts on the vertical chrome strips. Replace or adjust window.

Tighten cap nuts to 2-4ft.lbs (2.7-5.4 Nm), torque pressure.

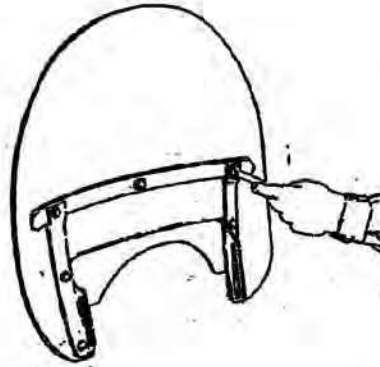

Use the screw removed from the front fork.

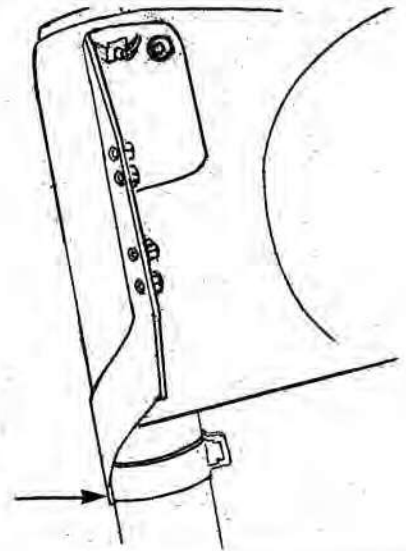

Diagram D.

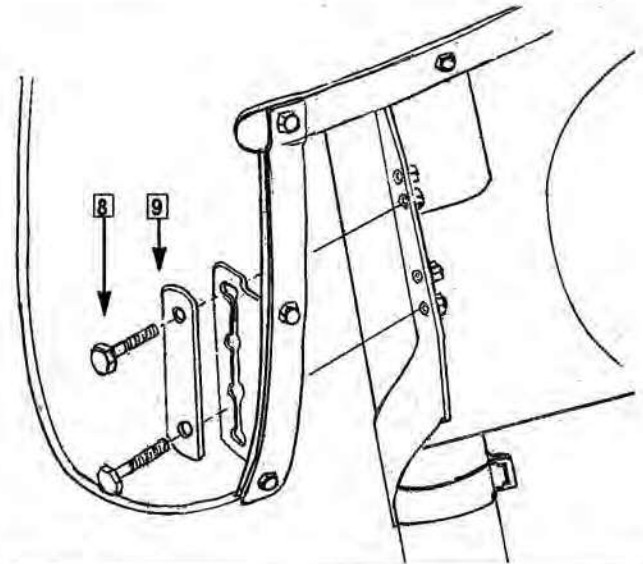

Diagram E.

WARNING

National cycle windshields and fairings are designed to provide wind protection and increased riding comfort, but not protection in the event of a collision with another vehicle, the road, birds, or any other object. Our products utilize certain features, patented and otherwise, that may minimize injury in certain accidents, but the possibility of injury exists if the screen is broken or if impacted by an object.

Always wear eye protection, helmets and protective clothing. Never ride your motorcycle while under the influence of drugs or alcohol.

All of our products are made in conformance and exceed the requirements of D.O.T. SS205,Z26.1, classifications AS6 and AS7, which covers all safety glazing for motorcycle application.

Never ride your motorcycle with loose windshield mounting hardware. Check the hardware for tightness regularly.

Today's motorcycles are built with enough frame rigidity to withstand the moderate loads imposed on them by the foreseeable addition of a fork mounted windshield.

If the addition of an accessory(ies) adversely affects your motorcycle's stability, immediately remove the accessory(ies). Do not ride a motorcycle that exhibits unsafe handling traits. Have experienced service personnel correct any problem before riding with the accessory(ies) installed. For further questions concerning handling problems associated with an accessory(ies), contact your dealer, motorcycle manufacturer, or accessory manufacturer.

MAINTENANCE AND CARE

CLEANING

To clean the screen, wash with a clean soft cloth, plenty of warm water and, if necessary, a non-abrasive soap such as dish-washing liquid. Flannel or soft chamois make good cleaning cloths. Paint, glue residue or grease removal: Moisten cotton with Naptha or Turpentine followed by a wash as above.

Apply a high quality plastic polish, such as McGuiar's Mirror-Glaze MGH-17 or Novus #2, to the clean screen. This will leave a protective coating in the screen making future cleanings easier. Do not clean polycarbonate in hot sun or high temperatures.

Do not clean the screen with glass cleaners. Do not use rain protective products on the screen. The solvent action of the alcohol in these products will destroy the screen. Do not allow brake fluid, alcohol, or strong solvents to contact the screen or penetrate between the chrome brackets and the polycarbonate. Permanent damage will result!

To remove scratches, use a very soft clean cloth and a fine grade buffing compound. Jewelers rouge or McGuiar's Mirror-Glaze MGH-10 are best for this type of buffing. We recommend hand buffing.

STORAGE

Do not use low quality vinyl covers or old shower curtains to store your motorcycle or windshield. These products damage the plastic of windshields and the motorcycle body.

TRIMMING

All National Cycle accessory and replacement windscreens are top quality wind protection devices. Proper care can help these windscreens give many years of motorcycling enjoyment.

Because each rider has their own combination of physical height and/or motorcycle accessories, trimming may become necessary for the best installation. National Cycle Heavy Duty products are made from polycarbonate and can be trimmed if a few simple procedures are followed. I'm sorry, we cannot be responsible for damage to the product which occurs during trimming.

NOTE: Use of jig saw or sabre saw is not recommended!

If the windscreen is to be shortened from the top, remember to choose the new height while seated on the motorcycle(both wheels on the ground), with it normally loaded. In all cases you should be able to see over the top of the screen at least by stretching, in case the screen should become opaque because of rain or dirt.

Too much should not be taken off the top as this will affect how far the air shoots off the top of the screen. The rake angle of the screen, which is adjustable in most applications, will also affect how the air comes off the screen.

Mark the line to be cut with a crayon or china marker; these can be easily washed off. A ruler or piece of paper can be used as a guide to duplicate the original shape.

Secure the windshield by gripping it with your knees. This leaves both hands free for filing or sanding.

The trimming should be done by sanding or filing with a coarse 60-80 grit file. Since shudders, jolts, and sudden shocks can promote cracking, a smooth continuous motion should be used. A flat belt sander will remove material quickly, but keep the sander moving back and forth for a smooth edge.

If a large amount of trimming is required, a band saw can be used safely. Protect the screen with masking tape before cutting. The blade should have about ten teeth per inch. A hack saw will also work well; be careful not to let it bind in the cut.

Once the desired shape is found, use the coarse file or sandpaper to round the edges. Any scratches that result from handling can be removed. Refer to the Maintenance instructions.