

SPECIAL NOTE

Dealers – if installing this Deflector Screen DX for a customer, please give him or her this manual. It contains the instructional and reference material needed to properly maintain and use this product.

This manual is designed for complete product knowledge. Take the time to become familiar with your Deflector Screen DX and its hardware to obtain the best results in use.

IMPORTANT

Please report any missing parts to your dealer or directly to National Cycle. The following information is necessary: bag number and serial number located on the outside of the plastic bag, and place of purchase.

ATTENTION

Special notes and cautionary measures which can prevent damage to the accessory or the motorcycle

NOTE

Tips for facilitation of operation, control, adjustment and maintenance

PARTS LIST

N2594/95 and Kit TT contains hardware for 7/8" (22mm) handlebars.
N2594A/95A and Kit AE contains hardware for 1" (25mm) handlebars.
N2594B/95B and Kit AH contains hardware for 1.25" (32mm) handlebars.

Complete kit cost: \$49.50

Bag #51 (KIT TT)

QTY.	PART NO.
2	44-440100
2	44-440200
1	59-515100
4	51-515200
2	44-446700

Complete bag cost: \$23.00
DESCRIPTION
Pivot Strap, 7/8" (22mm)
Pivot Mount, 7/8" (22mm)
3/16" Short Arm Hex Key
1/4-20 x 5/8" Hex Cap Screw
Double Stick Tape

Bag #77 (KIT AE)

QTY.	PART NO.
2	44-440110
2	44-440210
1	59-515100
4	51-515200
2	44-446700

Complete bag cost: \$23.00
DESCRIPTION
Pivot Strap, 1" (25mm)
Pivot Mount, 1" (25mm)
3/16" Short Arm Hex Key
1/4-20 x 5/8" Hex Cap Screw
Double Stick Tape

Bag #78 (KIT AH)

QTY.	PART NO.
2	44-440120
2	44-440220
1	59-515100
4	51-515200
2	44-446700

Complete bag cost: \$23.00
DESCRIPTION
Pivot Strap, 1.25" (25mm)
Pivot Mount, 1.25" (25mm)
3/16" Short Arm Hex Key
1/4-20 x 5/8" Hex Cap Screw
Double Stick Tape

Bag #52 (KIT TT and AE)

QTY.	PART NO.
1	44-440300
1	44-440600
2	44-440400

Complete bag cost: \$16.50
DESCRIPTION
Telescope Bracket, Left
Telescope Bracket, Right
QuickSet Knob

Bag #59 (KIT TT and AE)

QTY.	PART NO.
1	44-440810
1	44-440800
1	44-440710
1	44-440700
4	51-515300
2	44-440900
1	59-515110

Complete bag cost: \$19.00
DESCRIPTION
Ball End Rake Adjustment Arm, Left
Ball End Rake Adjustment Arm, Right
Rod Clamp, 5/16", Left
Rod Clamp, 5/16", Right
10-32 x 1/2" Hex Cap Screw
Wing Knob
5/32" Short Arm Hex Key

Bag #60 (KIT TT and AE)

QTY.	PART NO.
2	42-429000
2	34-344400

Complete bag cost: \$11.00
DESCRIPTION
Locking Nut, 3/4"
Upright, 5/16", 90° Bend

OPTIONAL BAGS #47 and #53

Needed for motorcycles with non-tubular handlebars.

Bag #47

QTY.	PART NO.
2	41-410500
2	37-370300
1	37-410400
1	37-410300
2	50-505710
2	49-492210
4	42-430010

Complete bag cost: \$22.50
DESCRIPTION
Flat Under Plate
Right Angle Bracket
Square Bar Clamp, Left
Square Bar Clamp, Right
5/16-18 x 5/8" Hex Cap Screw
Internal Lock Washer, 5/16"
WhizLock Nut, 1/4-20

Bag #53

QTY.	PART NO.
2	44-440500
2	42-432010

Complete bag cost: \$15.95
DESCRIPTION
Pivot Bracket, Non-Tubular
WhizLock Nut, 3/8-16

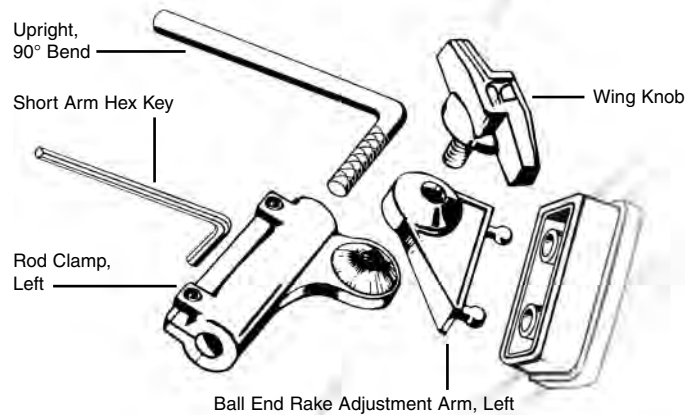
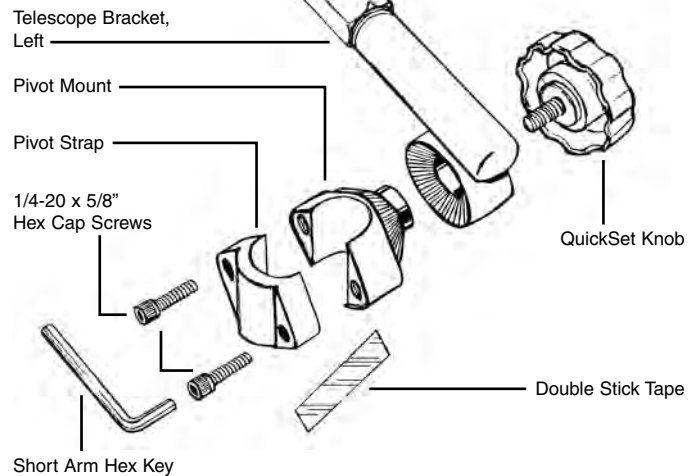
DIAGRAM 1
(Left Side Assembly)

DIAGRAM 2

ORDERING PARTS AND ACCESSORIES

All National Cycle parts and accessories can be purchased or ordered through your dealer.

1. OPEN ALL HARDWARE BAGS: Check contents against **Parts List** and **Diagrams #1** and **#2** below.

2. RAKE ADJUST ASSEMBLY: From Uprights and Bag #57, sort parts into left and right **Rake Adjustment Arm** assemblies (see **Diagram #1**). When left and right Rake Adjust hardware is properly assembled, the **Wing Knobs** will face to the **inside** of the Rake Adjust hardware. This will allow convenient access to the Rake Adjust feature when installed on the motorcycle.

To assemble, insert the short ends of the **Uprights** into the pivot ends of the **Rod Clamps**. Start the hex screws, but do not tighten. Attach the **Ball End Rake Adjustment Arms** (left and right) to the Rod Clamps at the pivot points, using the Wing Knobs. See **Diagram #1** for correct alignment. Tighten Wing Knobs securely.

3. INSTALL HARDWARE ONTO SCREEN: (The following steps must be performed in an air temperature of at least 60-65°F.) Place the screen front down on a scratch-free, well-supported surface (a blanket or towel on a tabletop or floor). Moisten the **Ball Ends** of the **Rake Adjustment Arms** with water or saliva only - no oils or lubricants.



ATTENTION

Any oils, silicones, greases or lubricants will adversely affect the impact release feature.

Firmly press the Ball Ends of the Rake Adjustment Arms into the screen's **Ball Sockets** until fully seated (see **Diagram #3**). It may be necessary to slightly warm the Ball Sockets with a hair dryer to ease assembly. Once assembled, the serrated pivots should be toward the top of the screen, and both Wing Knobs facing toward the center of the screen.

4. QUICKSET PIVOT MOUNT ASSEMBLY: (Installation and initial alignment will be easier with the motorcycle on its centerstand.) Pick appropriate spot on the vertical rise of the handlebars and attach **Pivot Mounts** to the **Pivot Straps** with 1/4-20 hex cap screws until snug, but not tight. Use hex key wrench supplied in hardware kit. Be sure both sides are symmetrical (see **Diagram #4**).

5. INSTALLING TELESCOPE BRACKETS: Slide both **Telescope Brackets** onto the Uprights of the Rake Adjust/screen assembly, **WITHOUT** the **Locking Nuts** to avoid scuffing the Uprights.

6. SCREEN INSTALLATION AND BRACKET ALIGNMENT: Set the Rake Adjust/screen assembly over the headlight and loosely attach the Telescope Brackets to the QuickSet Pivot Mounts with **QuickSet Knobs** (See **Diagram #5**).

For the most rigid installation:

(A) Set the screen on or close to the headlight at the desired rake angle. (B) Minimize the Upright extension from the Telescope Brackets. Slide the handlebar Pivot Mount assemblies further up the bar to reduce extension. (C) Adjust the Upright/Telescope Bracket combination at about 45° angle or greater with respect to the ground. More vertical angles are slightly less rigid. Mark the Uprights with masking tape to note their extension. (D) To maintain maximum rigidity, the screen should be "preloaded". Refer to **Step 9. FINAL ADJUSTMENT**.

7. LOCKING NUTS AND DOUBLE STICK TAPE: Now remove the Rake Adjust/screen assembly, and then the Telescope Brackets. You can now loosely screw the **Locking Nuts** onto the Telescope Brackets.

Mark the placement and rotational position of the Pivot Mounts on the handlebars, then loosen the Pivot Mounts and slide them out of the way. Place two strips of **Double Stick Tape** at the location on the handlebars where the Pivot Mounts were placed. Carefully move the Pivot Mounts back to their original position, over the Double Stick Tape, and tighten the Hex Cap Screws.



NOTE

The Double Stick Tape is necessary to avoid rotational slippage on certain models.

8. COMPLETING ASSEMBLY: Slide the Telescope Brackets back

DIAGRAM 3

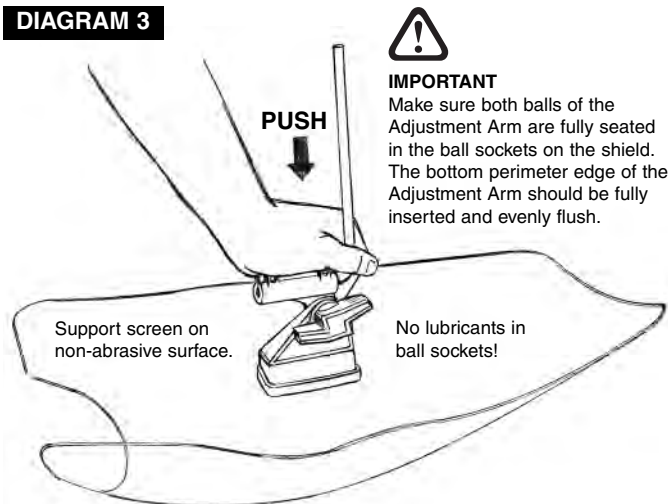

DIAGRAM 4

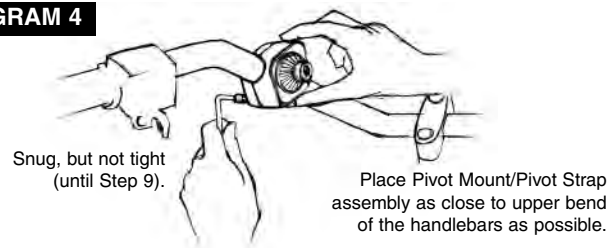

DIAGRAM 5

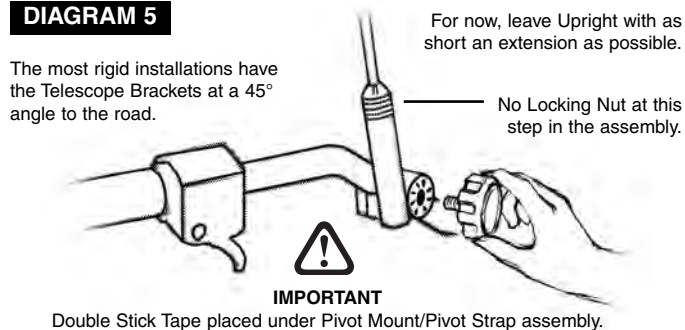
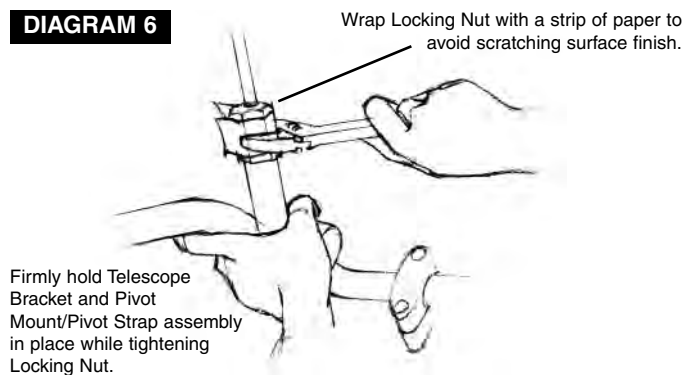

DIAGRAM 6



onto the Uprights of the Rake Adjust/screen assembly. Do not tighten the Telescope Bracket Locking Nuts yet. Install the Deflector Screen/Rake Adjust/Telescope Bracket combination onto the motorcycle, aligning the Telescope Brackets with the Pivot Mounts on the handlebars. Install the **QuickSet Knobs** through the **Telescope Brackets** into the **Pivot Mounts** and tighten securely.

Now slide the **Uprights** further down into the Telescope Brackets to the position you marked in **Step 6.C.** above. Tighten the Telescope

Bracket Locking Nuts finger-tight. Wrap Locking Nut with a strip of paper before final tightening with a 3/4" wrench, to avoid scratches or scuff marks (See **Diagram #6**). Tighten Locking Nuts securely.

9. CHECK ALL FASTENERS FOR TIGHTNESS: When the desired height and rake of your Deflector Screen DX is achieved, check and tighten (a) the four Hex Cap Screws in the Pivot Mounts, (b) the four Hex Screws in the Rod Clamps, (c) the two Locking Nuts on the Telescope Brackets, (d) the two QuickSet Knobs on the Telescope Brackets, and (e) the two Wing Knobs on the Rake Adjustment Arms.

10. FURTHER ADJUSTMENTS: (See **Diagram #7**). The rake of your Deflector Screen DX can now be changed at any time by simply loosening the two Wing Knobs, pivoting the screen on its mounts, and retightening the Wing Knobs.

To maintain absolute rigidity, the screen should be "preloaded" against some point of the headlight shell. With both Wing Knobs loose, lift on the left Upright with your left hand, and use your thumb to push the screen more vertical at the Rake Adjustment Arm, one notch at a time. This will force the gasket on the screen's lower lip into contact with the headlight shell. Tighten the left Wing Knob. Repeat this procedure on the right side to balance the preload adjustment.

If the degree of rake is too great after preloading, repositioning of the Uprights in the Telescope Brackets will realign the screen to your desired angle. Loosen the Telescope Bracket Locking Nuts, move the Uprights higher or lower, and then re-tighten the Locking Nuts.

SCREEN REMOVAL

To remove the screen, spin the QuickSet Knobs to release the Telescope Brackets and lift the windscreen assembly free from the motorcycle. No tools are required! The Pivot Mounts stay secured to your handlebars and in alignment for fast, tool-free reinstallation.

NOTE: The double Ball End Rake Adjustment Arms are not to be used as a removal point, and should not be disassembled repeatedly. If you need to remove the Uprights from the screen, detach at the Wing Knobs.



NOTE

The double Ball End Rake Adjustment Arms are not to be used as a removal point, and should not be disassembled repeatedly. If you need to remove the Uprights from the screen, detach at the Wing Knobs.

CLEANING

Pre-rinse your screen with water to remove surface grit. Use mild, non-abrasive liquid soap, warm water, and a clean, soft cloth/sponge or wet chamois to wash the screen. Rinse again, as all residue must be removed. Wipe dry with a chamois or soft sponge to prevent water spots.

PAINT, GLUE OR GREASE REMOVAL

Moisten a ball of cotton or soft cloth with naphtha or turpentine and gently scrub to remove paint, glue or grease. Follow with a soap and water wash as described above.



WARNING

DO NOT USE ALCOHOL SOLUTIONS OR GLASS CLEANERS to clean your screen. **DO NOT** use rain protective products on this screen. Alcohol solutions, brake fluids, and strong solvents will permanently damage the screen.

HAIRLINE SCRATCHES AND ABRASIONS

Small scratches can be removed or minimized with a mild automotive glazing compound or a high quality plastic polisher. **NOTE:** Test on a small sample area first. Recommended polishing products include Novus 2 Fine Scratch Remover, McGuiar's Mirror Glaze MGH-17, and The Wax Shop's Safe Cut Swirl & Haze Remover. Flannel or chamois make good polishing cloths. We recommend hand buffing for best results. Keep moving across the scratch while buffing. Try not to concentrate on a small area, which can distort the windscreen's optics.

Today's motorcycles are built with enough frame rigidity to withstand the moderate loads placed on them by the foreseeable addition of a windshield.

DIAGRAM 7

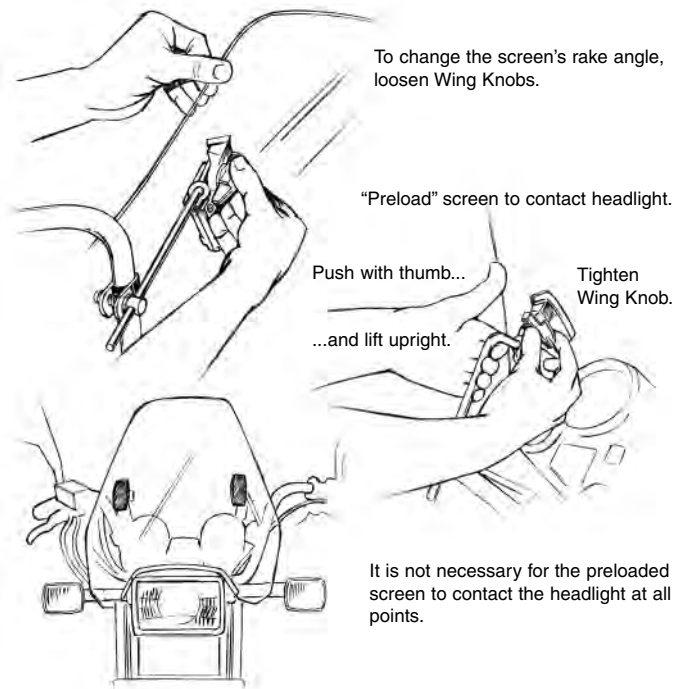

CAUTION

Never ride your motorcycle with loose windshield mounting hardware. Check the hardware for tightness regularly.

If the addition of an accessory(ies) adversely affects your motorcycle's stability, immediately remove the accessory(ies). **Do not ride a motorcycle that exhibits unsafe handling characteristics.** Have experienced service personnel correct any problems before riding with the accessory(ies) installed. For further questions concerning handling problems associated with an accessory(ies), contact your dealer, motorcycle manufacturer, or accessory manufacturer.

Sunlight reflected off the inside curvature of a windshield can, at certain times of the day, cause extreme heat buildup on the motorcycle's instruments and possibly even melt them. Exercise care in parking to avoid this. Park facing the sun or place an opaque object over this area.

National Cycle windshields and fairings are designed to provide wind protection and enhanced comfort, but not protection in the event of a collision with another vehicle, the road, or any other object.

Some of our products use certain features, patented and otherwise, that may minimize injury in certain accidents, but the possibility of injury exists if the windscreen is broken.

The acrylic sheet that is used in our Deflector Screen™ is almost 30X more impact resistant than glass. If it is subject to impact beyond its resistance, it breaks into comparatively large pieces, and does not normally shatter into small slivers.

All of our products are made in conformance and exceed the requirements of D.O.T. SS205, Z26.1, classifications AS6 and AS7, which cover all safety glazing for motorcycle applications.

Plexifairing GT, Plexifairing 3, Plexistar 2, Deflector Screen, Deflector Screen DX, Streetshield, Streetshield EX, FlyScreen, QuickSet3, Rake Adjust, and No-Hole Ballsocket are covered by one or more of the following patents: 4082345, 4168098, 4379584, 4489973, 5732965, 578833, 6254166, 6484914.