



## **INSTALLATION INSTRUCTIONS**

# **YAMAHA MT 07 2014-**

plate holder

# INSTALLATION INSTRUCTIONS

## Plate holder

*Thank you for buying a MRA Windshield.*

*Read this manual carefully and check the parts list for completeness before you begin. We recommend that you have your screen fitted by an authorised workshop.*

Number	Article	Article No..	Required tools
1	Adapter plate	11313	Allen key 2.5, 3, 4, 6mm Wrench 8mm Open-end spanner 7, 10mm Flat-head screwdriver
1	<b>Plate holder comprising:</b>		
	1 base plate	11305	
	1 reflector mounting	11314	
	2 indicator brackets	11315	
1	number plate light LED with 2 cross head screws	11289	
1	reflector, rectangular with 2 nuts	11290	
2	Allen screws with flange, M6 x 10 mm	11291	
2	Allen screws with flange, M5 x 8 mm	11292	
2	Allen screws with flange, M4 x 8 mm	10562	
2	stop nuts, black, M4	10772	
2	stop nuts, black, M5	11000	
2	washers, black, 5.3 mm	10999	
2	washers, 13 x 6 x 0.5 mm	10669	
2	plastic washers, 12 x 5 mm	10635	

### General notes

*Always follow the instructions in your motorcycle manual while working on or making alterations to your motorcycle. Stand your motorcycle up on a level surface, and make sure that it is safe from falling over. We recommend that you label each of the electrical connections before disconnecting them. Reuse original connectors if possible. Subsequent alterations by welding, soldering, bending, or drilling, or improper installation will result in loss of guarantee. Use the original screws for installation unless stated otherwise.*

### Plate holder installation instructions:

#### A) Removal of the original plate holder

1. Remove the seat and the rear seat cushion.
2. Disconnect the vehicle's battery.
3. Tip: mark the electrical connections appropriately before detaching the connectors for the plate light and indicators. The connectors can then be detached and removed. Remove the plate, followed by the original plate holder as described in the workshop manual.

#### B) Installation of the MRA plate holder

4. Install the MRA adapter plate on the base plate using the M6 x 10 mm Allen screws with flange and the 6 mm plastic washers (please do not tighten the screws fully yet).
5. Install the M4 x 8 mm Allen screws and the M4 stop nuts at the plate holder (see illustrations). Do not tighten the screws fully yet.
6. Install the indicator brackets at the plate holder using the M5 x 8 mm Allen screws with flange and the 5 mm plastic washers. Align the indicator brackets with your number plate and tighten the screws fully (P1).

7. Install the reflector at the mounting bracket. Install the bracket for the reflector with the 5 mm stop nuts and the 5 mm washers at the plate holder no. 4630 and tighten the nuts and screws. Install the number plate light on the plate holder using the two cross head screws (P3+P4).

### **C) Installation of the MRA plate holder on the motorcycle**

8. Install the MRA plate holder with the 4 provided 6 x 12 mm Allen screws at the vehicle and tighten the screws.
9. Adjust the angle of inclination for the plate holder. ! The adjustment angle may not exceed **30°** to the vertical.
10. Tighten the M5 and M4 Allen screws.
11. Install the indicators at the plate holder. As an option, any additional accessory indicators can now be installed (not included in the scope of delivery).
12. Now connect the electrical cables for the plate light and indicators.  
**! All electrical wiring must be properly insulated and fixed with cable ties such that it cannot be squashed and no short circuits can occur.**
13. You can now reattach the battery and then check the functioning of the lights.
14. The disassembled components can now be reattached in reverse order.  
Finally, reinstall the license plate, the seat cushion and the seat.

*Important note: If you have a EURO 4 model, you will need to replace any reflectors originally mounted onto the old registration plate holder when installing your new registration plate holder. You may mount the replacements on another part of your bike, such as on the forks.*

**Check that the screws are still tight and tighten them again if needed after installation, and repeat at intervals after that.**

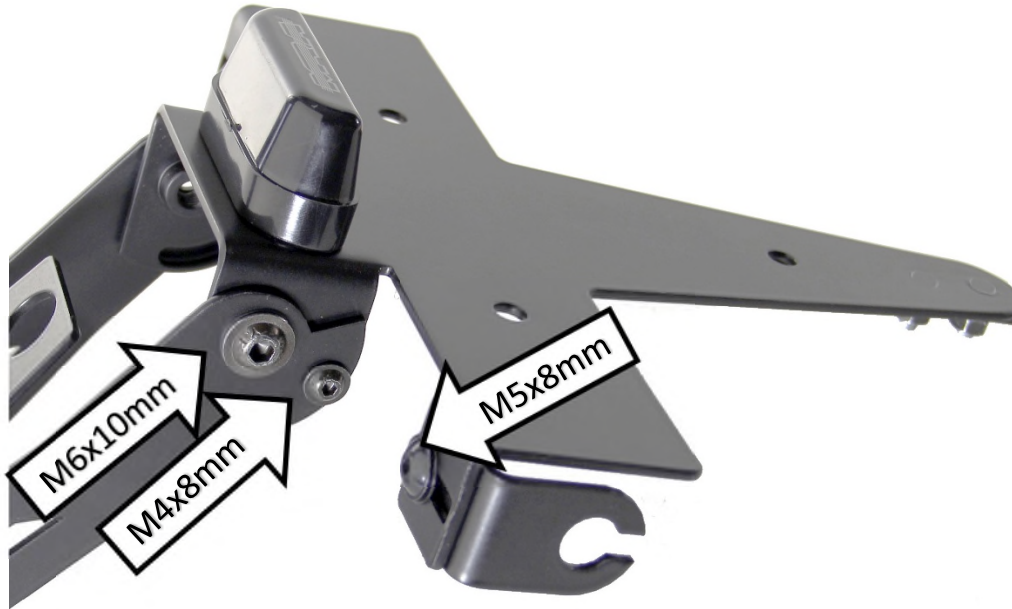

**P 1**

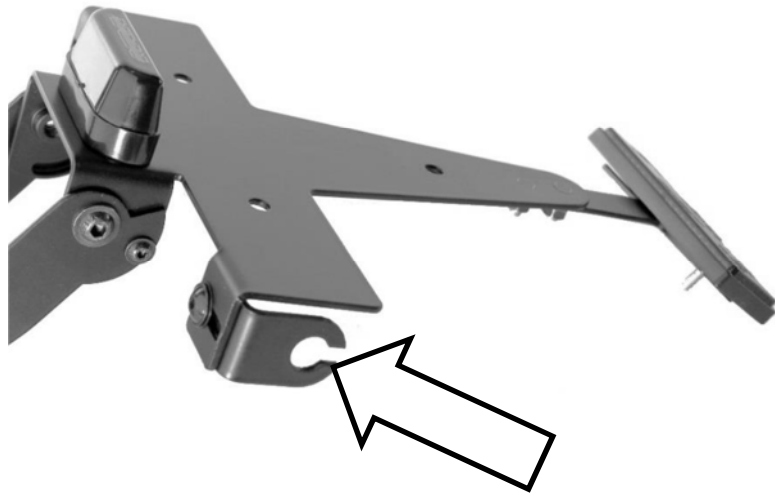

P 2

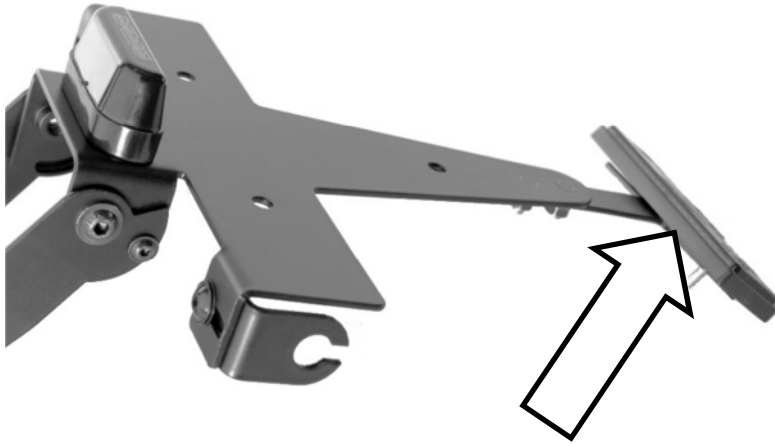

P 3

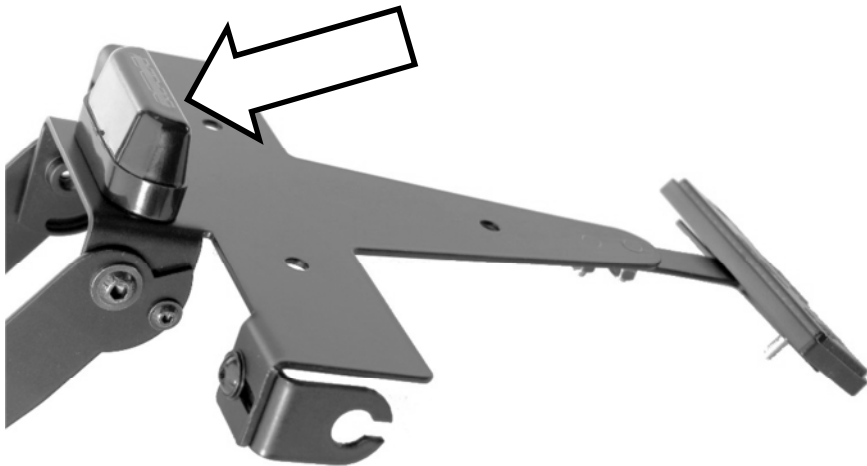

P 4



**P 5**



## **INSTALLATION INSTRUCTIONS**

# **YAMAHA MT 07 2014-**

© by MRA-Klement GmbH – 11/2017 4025066148820

## INSTALLATION INSTRUCTIONS

### YAMAHA MT 07 2014-

*Thank you for buying a MRA Windshield.*

*Read this manual carefully and check the parts list for completeness before you begin. We recommend that you have your screen fitted by an authorised workshop.*

Number	Article	Article No..	Required tools
1	MRA-Screen	---	Allen key 3 & 4mm
1	Pair of holding plates	11012	
4	Screws M5 x 16	10554	
4	Plastic washers	10635	
4	Rubber nuts	10629	
1	Edge protection strip, clamp sleeves	---	

#### **Fitting the screen to the motorcycle:**

1. Stand your motorbike up on a level surface.
2. Fasten the mounting plates using the original screws, and place the rubber nuts into the holes (P1).
3. Position your MRA racing screen, and fasten it using the M5x16 screws and plastic washers.
4. Apply the edge guard profile to the exposed rear area of the windshield, starting at the fairing transition and ending at the opposite side. Cut off the rest if required
5. It is also possible to push the clamping sleeves over the ends of the protective edge strip and lightly compress these using a pair of pliers to secure the edge strip.

**After installation, check that all of the screws are tight; tighten them up if necessary. Repeat this at regular intervals. Clean the screen with water, neutral soap and a sponge. Do not use solvents, alcohol or spirits to clean the screen as they will damage it.**





**P 1**



**P 2**