

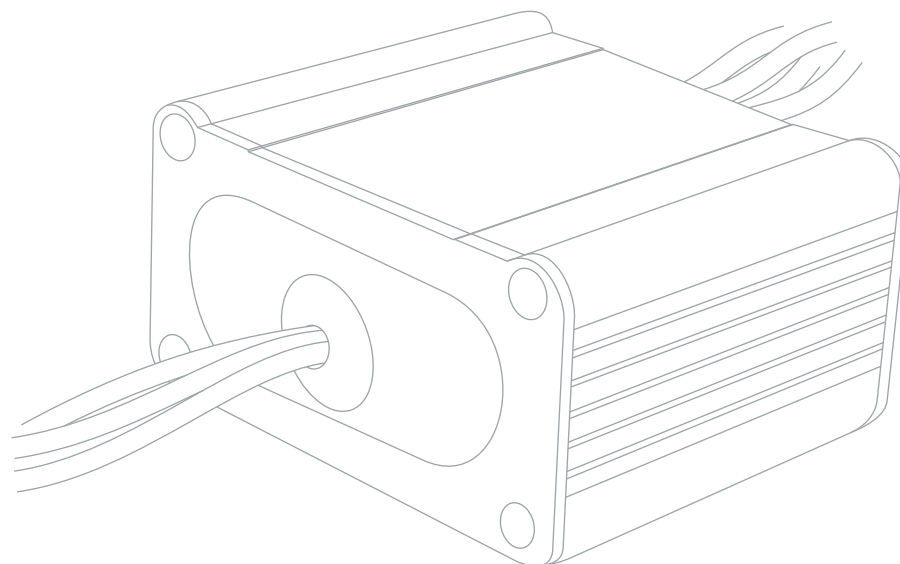

THE AUTOMOTIVE LIGHTING BENCHMARK



INSTALLATION GUIDE

XCHANGE DRIVERS





WARNING: By reading this document, I agree it is only to be used as an educational guide. Morimoto Lighting makes no guarantee on any finished results, nor are they to be held responsible for any damage, misuse, or personal injuries. Use at your own risk. If you are unable to clearly understand and adapt the information below to your own application, professional installation is recommended.

TABLE OF CONTENTS

INSTALLATION TYPES (CHOOSE YOURS)

DRL WIRING FUNCTION	3
SWITCHBACK FUNCTION	4

STANDARD PARTS

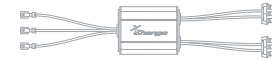

2X XCHANGE DRIVERS



6X BLUE T-TAPS



SPECIAL NOTES

THE XCHANGE DRIVERS ARE NEGATIVE-SWITCHED AND NOT POWER-SWITCHED. BECAUSE OF THIS, THEY MAY NOT BE COMPATIBLE WITH ALL LIGHTING COMPONENTS ON THE MARKET.

BOTH THE INPUTS AND OUTPUTS ARE WIRED FOR 12V+ AUTOMOTIVE OR COMPARABLE APPLICATIONS ONLY.

DRL WIRING FUNCTION

THIS WIRING SCHEMATIC IS USED FOR THE INSTALLATIONS WHERE A DRL SIGNAL IS NEEDED BUT DID NOT PREVIOUSLY EXIST. WHEN THE CAR IS TURNED ON, THE SIGNAL FROM THE VEHICLE TURNS THE XCHANGE DRIVER ON, THUS TURNING THE LIGHTING DEVICE OF YOUR CHOICE ON AS YOUR DAYTIME RUNNING LIGHT. ONCE THE LOW BEAMS ARE TURNED ON, THE DRL SIGNAL IS DROPPED, AND RETURNS ONLY WHEN THE LOW BEAMS ARE TURNED OFF WITH THE VEHICLE STILL RUNNING.

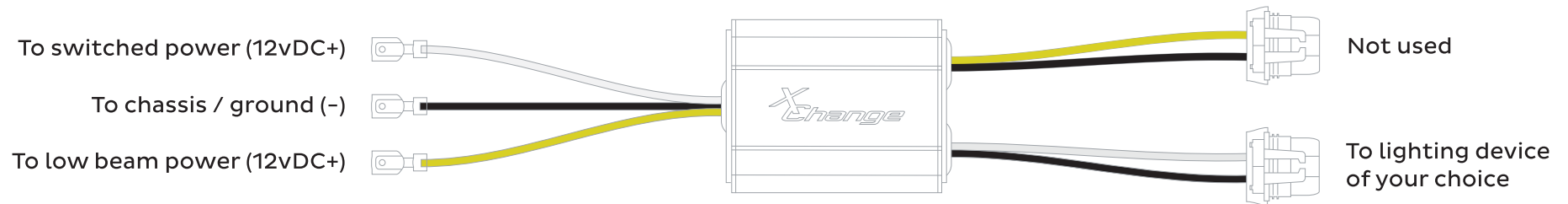

SWITCHBACK WIRING FUNCTION

THIS WIRING SCHEMATIC IS USED FOR THE INSTALLATIONS WHERE THE RUNNING LIGHT IS ILLUMINATED CONSTANTLY BASED ON A POWER SOURCE'S SIGNAL. WHEN THE VEHICLE'S INDICATOR IS SWITCHED ON, THE ILLUMINATED LIGHTING DEVICE TURNS OFF, AND A SECOND LIGHTING DEVICE IS ILLUMINATED CONCURRENT WITH THE INDICATOR'S TIMED SEQUENCE. ONCE TURNED OFF, THE ORIGINAL RUNNING LIGHT RETURNS AFTER A BRIEF PAUSE.

