

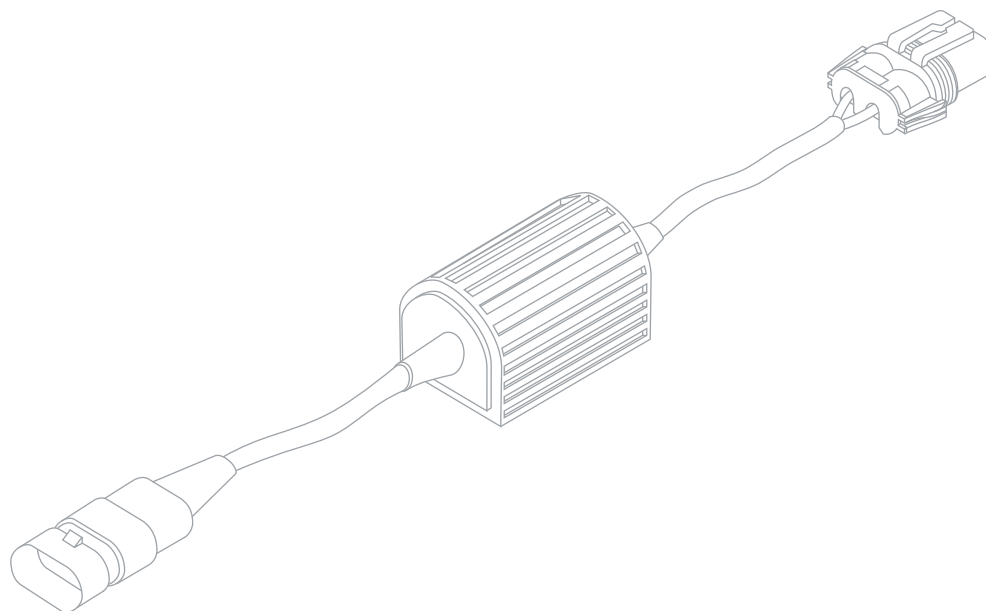

THE AUTOMOTIVE LIGHTING BENCHMARK



INSTALLATION GUIDE

STANDALONE CANBUS HARNESSES





WARNING: By reading this document, I agree it is only to be used as an educational guide. Morimoto Lighting makes no guarantee on any finished results, nor are they to be held responsible for any damage, misuse, or personal injuries. Use at your own risk. If you are unable to clearly understand and adapt the information below to your own application, professional installation is recommended.

TABLE OF CONTENTS

SYSTEM DIAGRAM (CHOOSE YOURS)	P.2
EXTERNALLY WIRED	P.3
INTERNALLY WIRED	P.4
DUAL FILAMENT	P.5
HARNESS INSTALLATION	P.6

STANDARD PARTS



2x CANBUS HARNESSSES

SPECIAL NOTE

Standalone CANBUS harnesses are for use in many popular European vehicles as well as other fitments. Certain CANBUS systems require different harness setups for proper function and “bulb check” error avoidance. Consult your Authorized Morimoto dealer for further information and recommendations.

SYSTEM DIAGRAMS



NOTE: System diagrams are to be used for reference purposes only. If you are unsure of the installation procedure for any individual part, review its install procedure prior to proceeding.

IDENTIFYING YOUR INSTALLATION TYPE



NOTE: There are three types of wiring installations for HID systems:

- EXTERNALLY-WIRED LOW BEAM
- INTERNALLY-WIRED LOW BEAM
- DUAL FILAMENT

The installation diagrams that follow will cover all three types.

EXTERNALLY-WIRED LOW BEAM

Separate low and high beam bulbs; When you can access the bulb from the back of the headlight without removing any caps or covers. Wiring for the bulb is visible and accessible outside of the housing.



Proceed to P.3

INTERNALLY-WIRED LOW BEAM

Separate low and high beam bulbs; When you must first remove a cap (generally plastic) to access the bulb. Inside the housing, there is wiring going to the bulb.

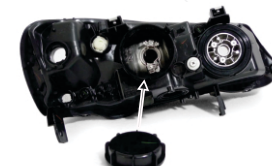

Proceed to P.4

DUAL FILAMENT

Shared low/high beam bulb; You can access the bulb from the back of the headlight without removing any caps or covers. Wiring for the bulb is visible and accessible outside of the housing.



Proceed to P.5

Right Side of Vehicle

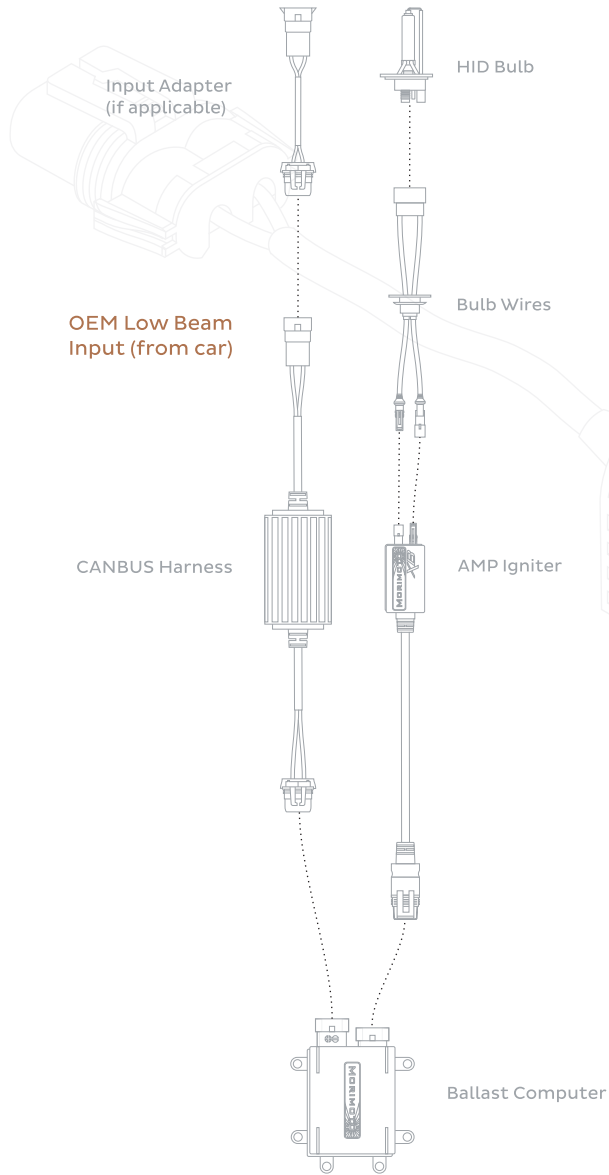

Left Side of Vehicle

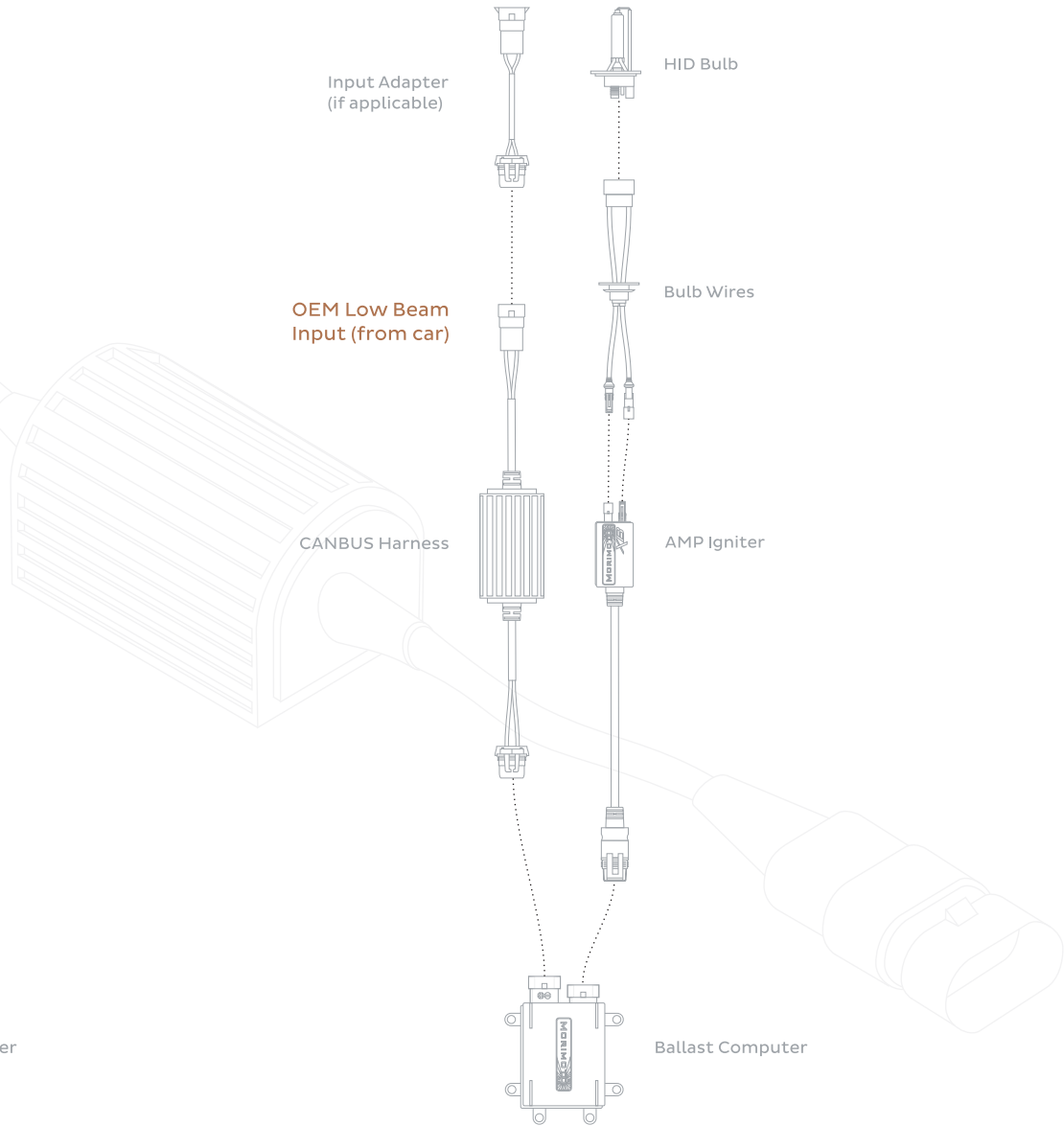

Right Side of Vehicle

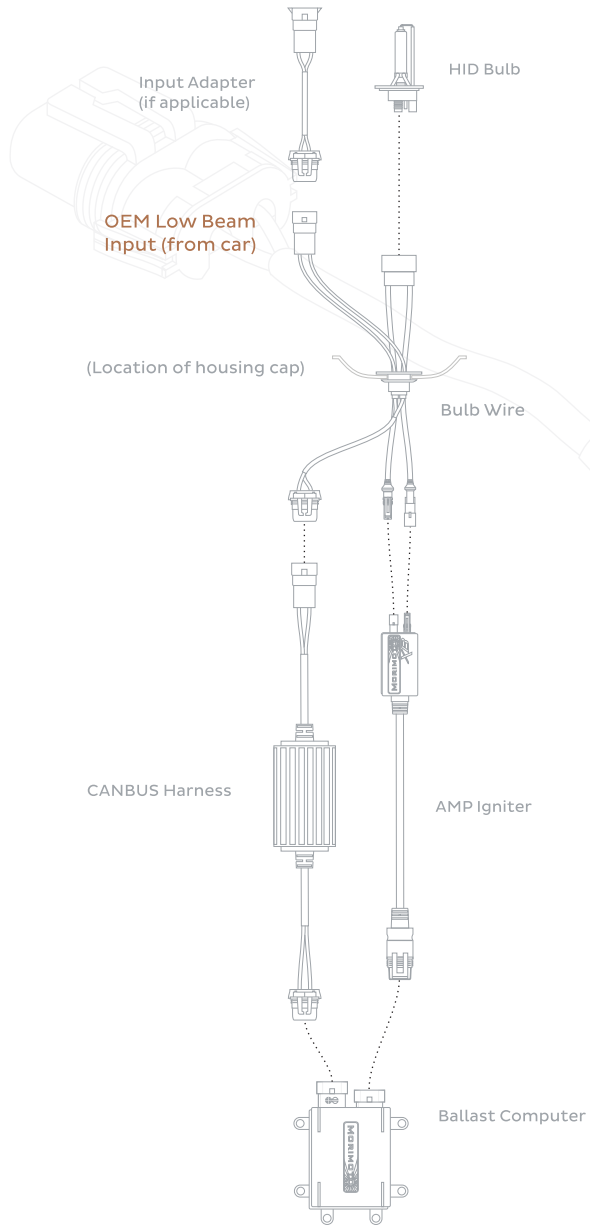

Left Side of Vehicle

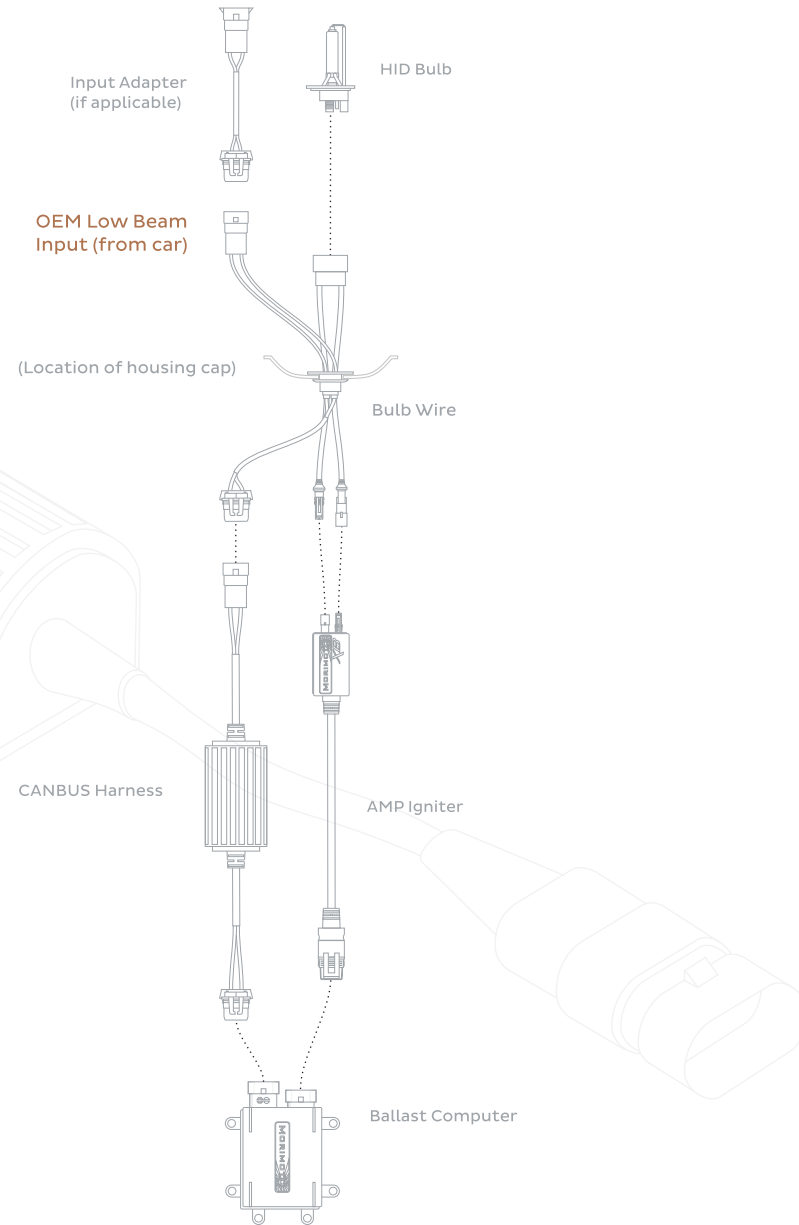

Right Side of Vehicle

Left Side of Vehicle

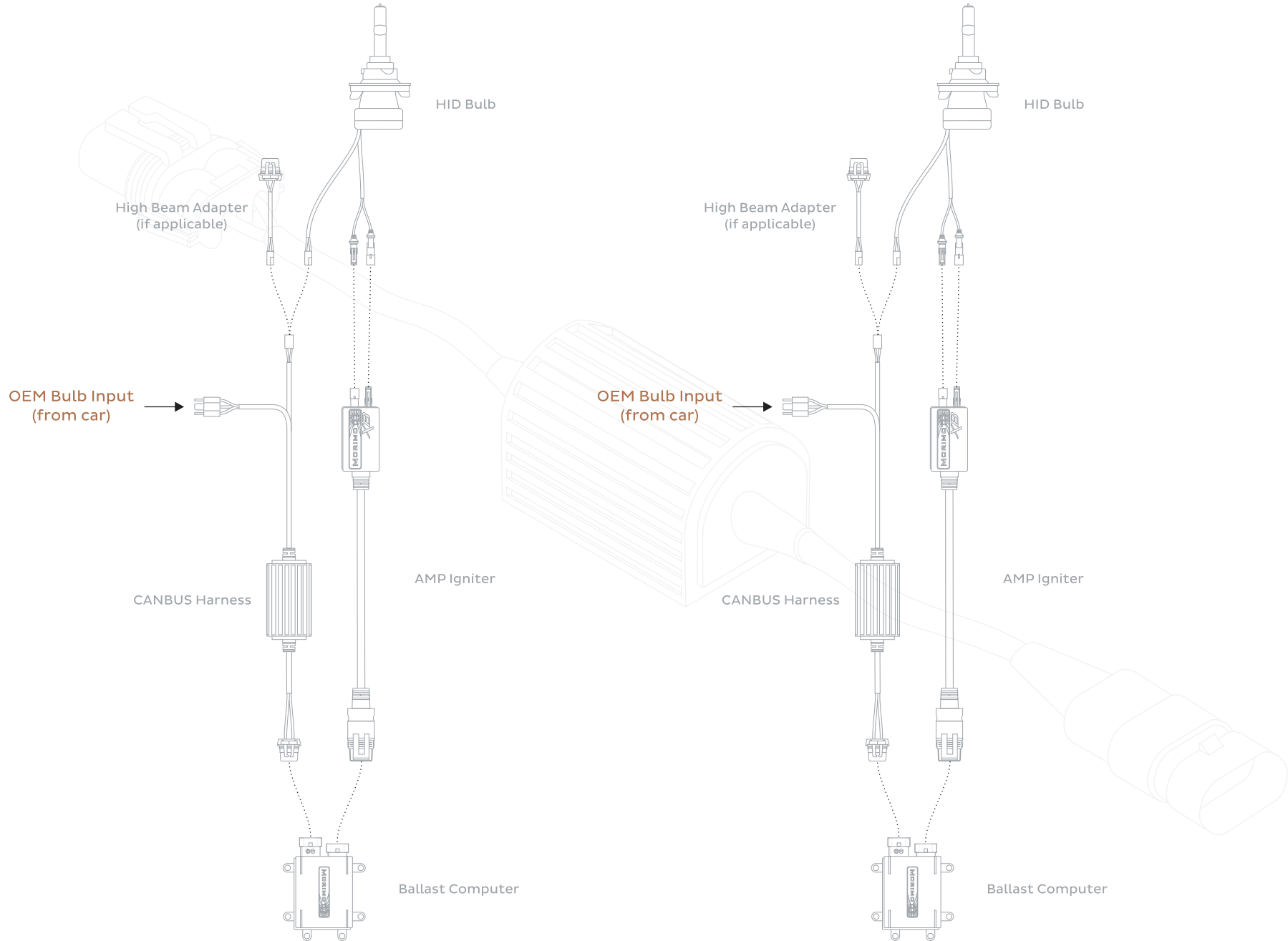

HARNESS INSTALLATION

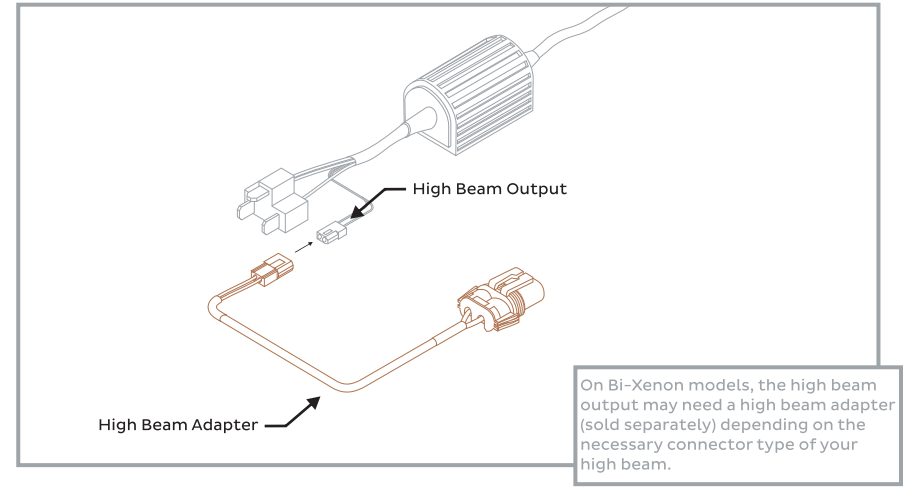
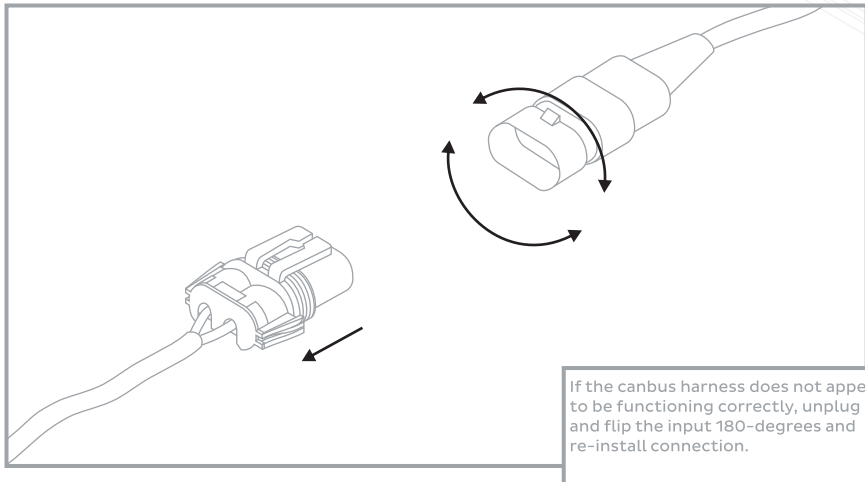
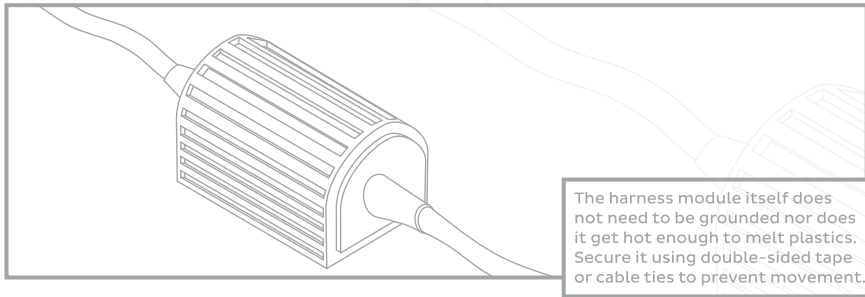
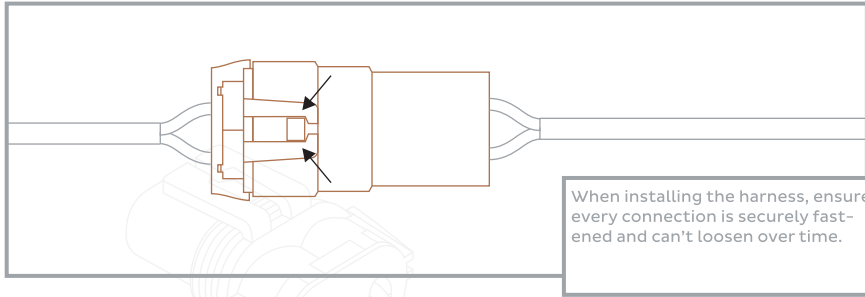

-END-