



Part Applications

- Harley Davidson Touring models 1997-UP* with OE highway bars Road Glide, Road King, Street Glide, Electra Glide (†)
- (†) Does not fit Twin-Cooled® models
- (†) Does not fit mustache-style highway bars

Part Components

A) Lower Fairing Speaker enclosure (L & R)



B) Speaker Grille 1 (H-D style)



C) Speaker Grille 2 (Flush style)



C) Mounting Hardware



Harley-Davidson® 1997-up* Lower Fairing Audio Kit

Note: This instruction sheet references service manual information. Service manual for year/model motorcycle is required for this installation. This Installation will reuse hardware from the existing mounted lower fairing.

Product Features

- 6.5" speaker mounting
- Color matched vivid black
- Includes two style metal grilles
- SS Mounting hardware included

TABLE OF CONTENTS

| | |
|----------------------------|-------|
| Preparation..... | 2-4 |
| Fairing Installation..... | 5-8 |
| Speaker Installation..... | 9-11 |
| Grille 1 Installation..... | 9 |
| Grille 2 Installation..... | 10-11 |

TOOLS & INSTALLATION ACCESSORIES REQUIRED

- Torx® Drivers T-10, T-15, T-20, T-25
- Phillips screwdriver
- Standard and metric socket wrenches.
- 3/8 Drill bit
- Blue Thread-locker
- Butyl caulk tape (dum dum)

Attention! We recommend removing the main battery fuse prior to installation. When testing the after-market equipment, ensure that all factory equipment is connected before cycling the key to ignition.

PREPARATION

Attention! This instruction manual references Harley-Davidson service manual information. A service manual for this year/model motorcycle is recommended for installation. One is available from a Harley-Davidson dealer.

Attention! To prevent accidental vehicle start-up, which could cause death or serious injury, remove main fuse or disconnect battery before proceeding.

Main fuse removal

1. If equipped, Open left side saddle bag lid.
2. Rotate (2) mounting studs counter clockwise until released, then lift off saddle bag
3. Remove left side access cover.
4. **For vehicles equipped with security siren:** Verify that the Hands-Free Fob is present.
5. Cycle the key to the ignition position.
6. Remove main fuse.

(Figure A)

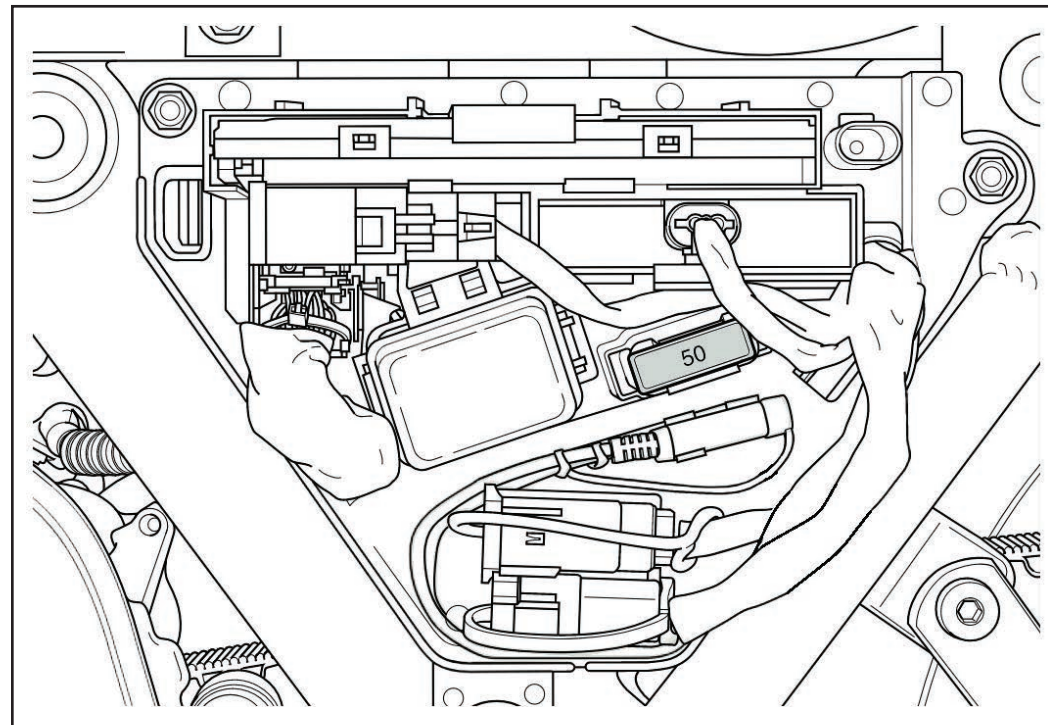

(Figure A)

Continue to installation

PREPARATION

Fairing Disassembly

1. Remove speaker grille.
2. Remove screw securing the lower fairing cap .
(Figure B.1)
3. Remove fairing cap.
(Figure B.2)
4. Remove (2) 7/16 in. flange nuts securing upper clamp.
(Figure B.3)
5. Proceed to installation

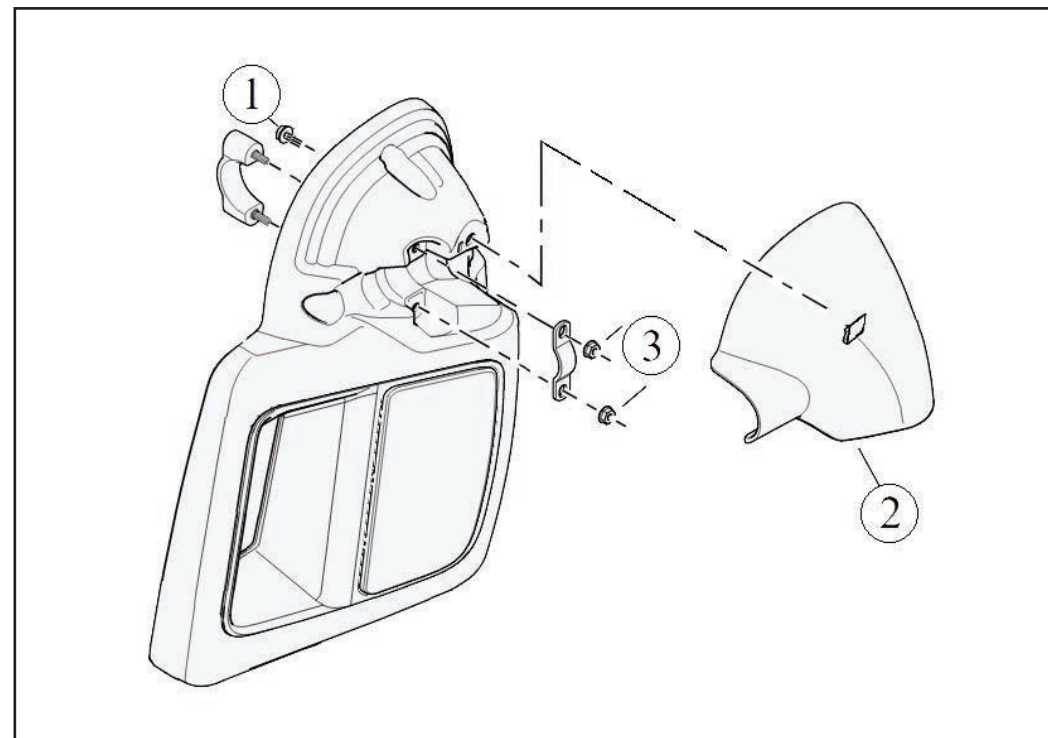

(Figure B)

PREPARATION

Speaker Wire

1. On the back side of the fairing, measure about 25 mm (1.0 in) over and 9.5 mm ($\frac{3}{8}$ in) up from the lower fairing cap mating flange. (Figure C.1)
2. Mark the location to drill the hole. Cover the drill point with masking tape to prevent cracking or chipping of the paint. Drill a 9.5 mm ($\frac{3}{8}$ in) hole in the glove box inboard side wall. (Figure C.2)

***Optional:** Insert a grommet to protect the speaker wires.

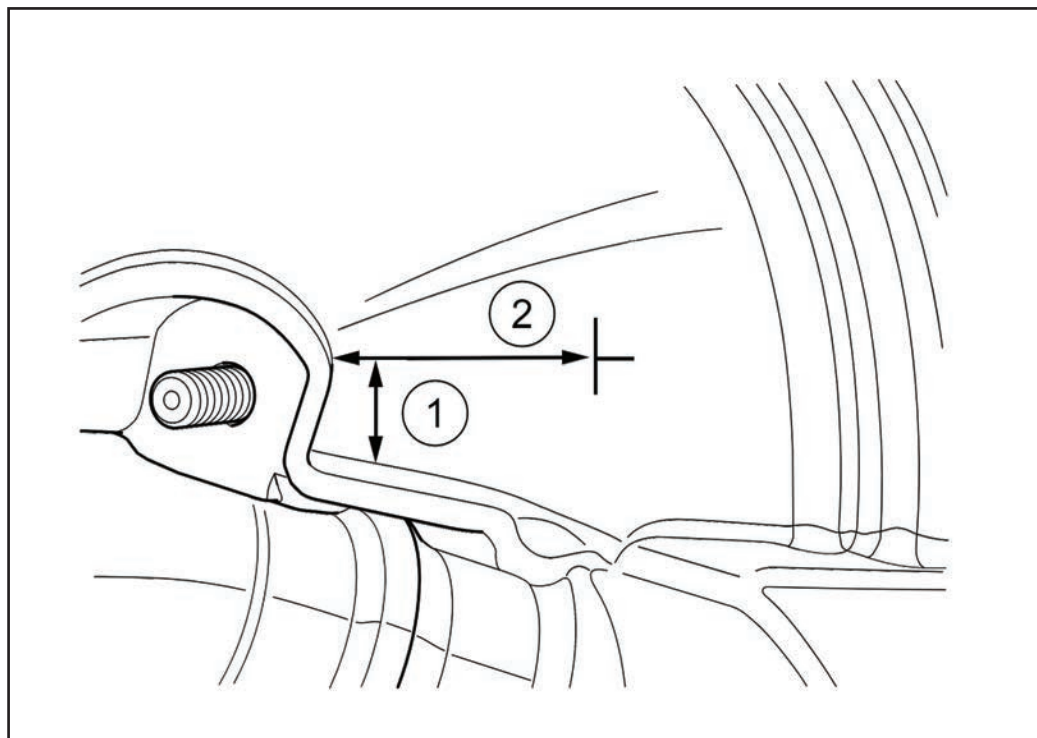

(Figure C)

Continued on next page

FAIRING INSTALLATION

1. Hold the lower fairing in place on the highway bar.
 2. Attach upper clamp and two (2) flange nuts.
- (Figure D)



(Figure D)

Continued on next page

FAIRING INSTALLATION

1. Install lower clamp, washer, screw and nut, do not tighten at this time leave loose.
(Figure E)



(Figure E)

Continued on next page

FAIRING INSTALLATION

1. Align the upper clamp to dimensions 10-1/8 in. (257.2 mm).
(Figure F.1).
2. Torque upper clamp flange nuts to 30–35 in-lbs (3.4–3.9 Nm)

NOTE: Clearance from the vent openings to the shift lever and brake pedal should approximate match the distance shown on specifications page.

ATTENTION: Verify shift lever and brake pedal do come in contact with lower fairing vent.
(Figure F.2,.F.3)
(2)...1/2 in. (13.0 mm)
(3)...1-1/4 in. (31.8)

3. Once the fairing is aligned properly.
4. Tighten the lower clamp mounting screw and nut to 90-100 in-lbs (10.2-11.3 Nm).
5. Route the speaker wires through the hole in the lower fairing.
6. Route the wiring harness under the fairing up to the radio and connect to either radio (without amp) or amplifier (with amp).
7. Secure wire harness and verify wiring does not interfere with steering or suspension travel.

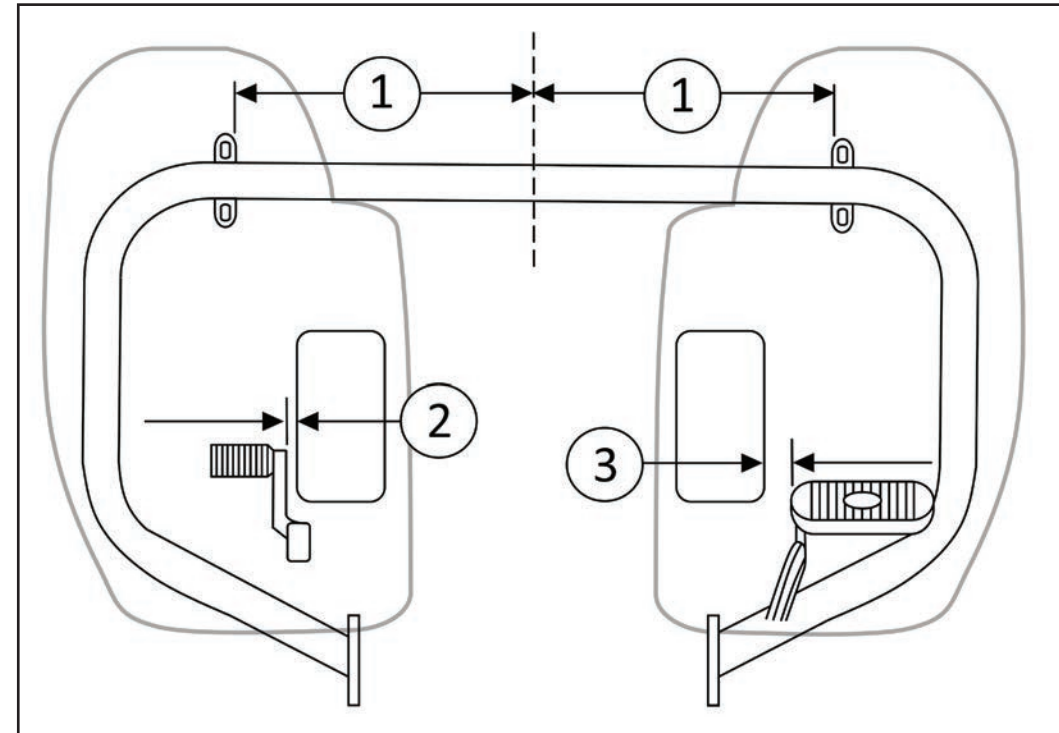

(Figure F)

Proceed to Speaker installation

FAIRING INSTALLATION

Lower fairing cap

1. Install fairing cap with screw.
(Figure G.1,G.2)
2. Tighten fairing cap snug. 30–35 in-lbs (3.4–3.9 Nm)

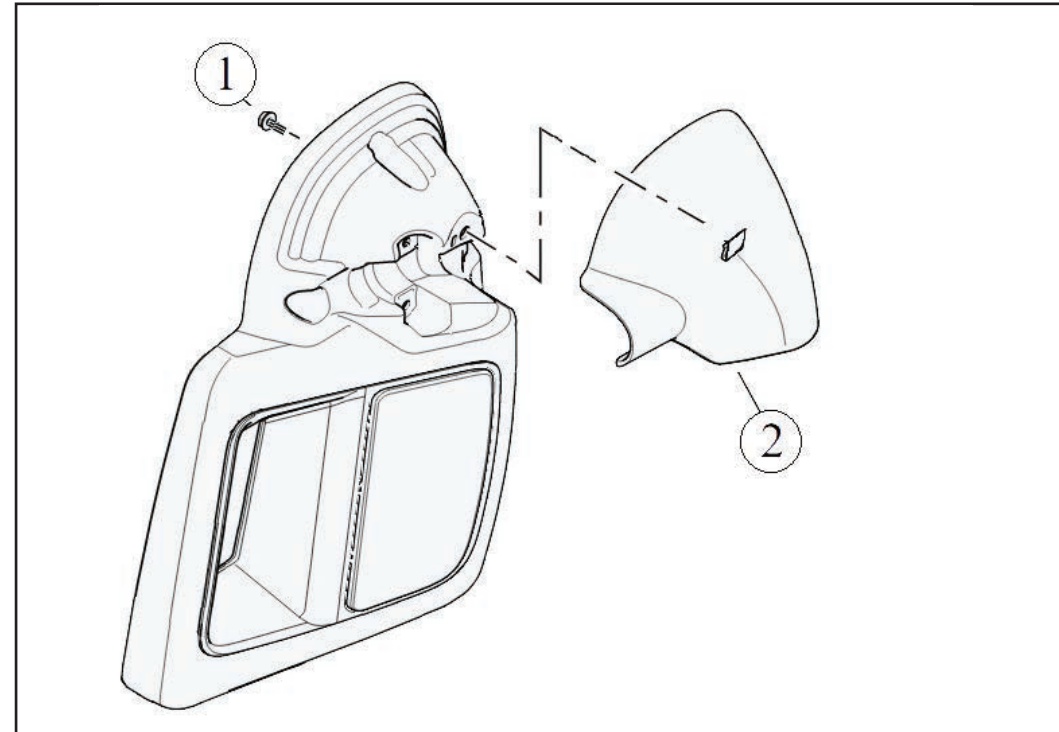

(Figure G)

Proceed to Speaker installation

SPEAKER INSTALLATION

Speaker Grille 1 (H-D style)

1. Place the 6.5 in speaker with in the opening of the grille.
2. Make sure that the speaker sits flush with the grille.
(Figure H)
3. If the speaker does not sit flush, trimming of the screw mount will be necessary.
(Figure H.1)
4. Connect the speaker wires to the speaker.
5. Mount the speaker with grille cover, using the supplied #10 1-3/4 in. screws.

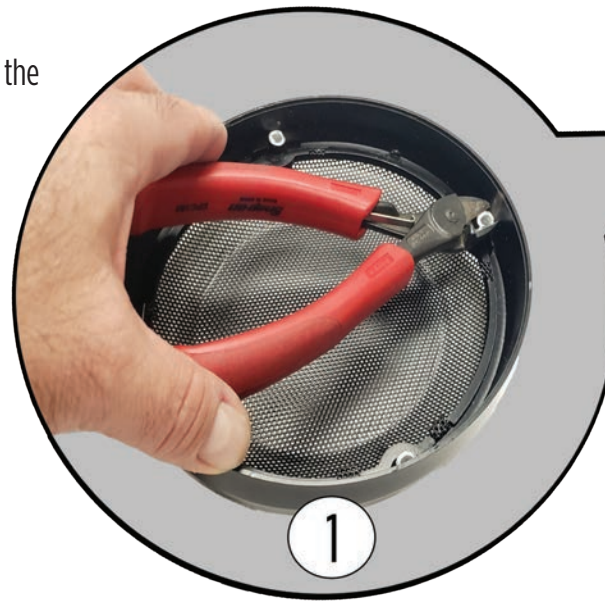

(Figure H)

SPEAKER INSTALLATION

Speaker Grille 2 (Flush style)

1. Connect the speaker wires to the speaker.
2. Mount the speaker with grille cover, using the supplied #10 1-3/4 in. screws.
3. Apply butyl caulk tape to the grille mount openings.
(Figure 1)
4. Install the speaker grille covers by inserting the tabs through the openings.

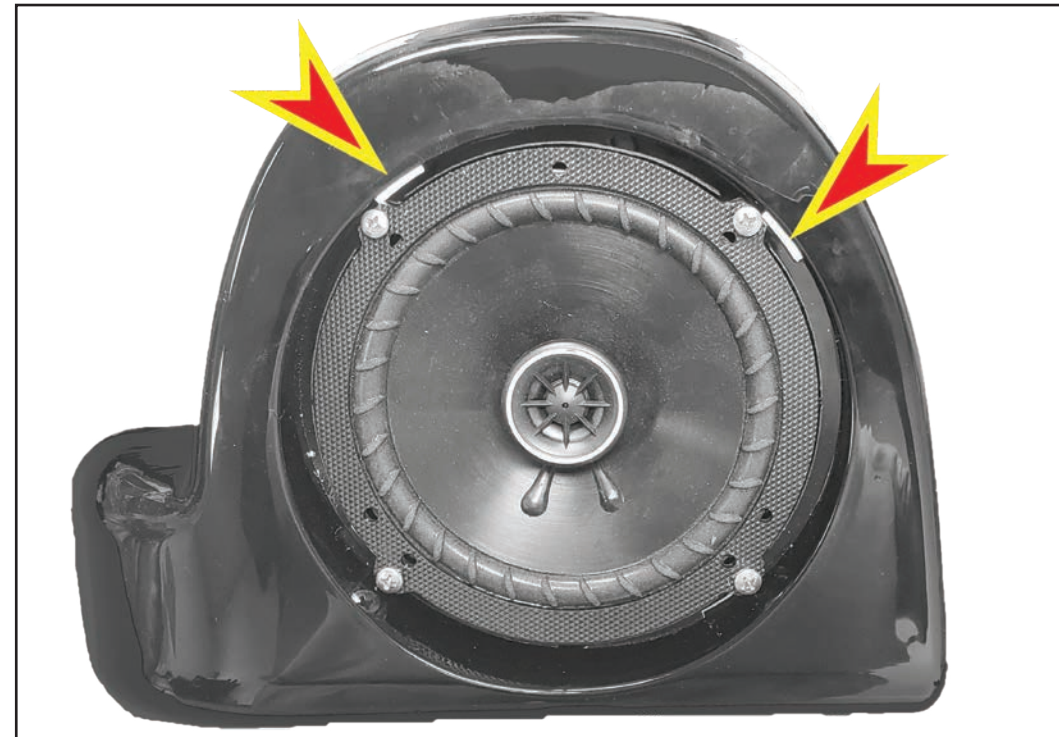

(Figure 1)

Continued on next page

SPEAKER INSTALLATION

Speaker Grille 2 (Flush style)

1. Once the grille tabs are inserted, reach under the pod to access the (2) bottom tabs. (Figure J)
1. Bend the grille tabs to lock the grille in place. (Figure J.1)

NOTE: The two upper grille tabs are secured by the butyl caulk tape.

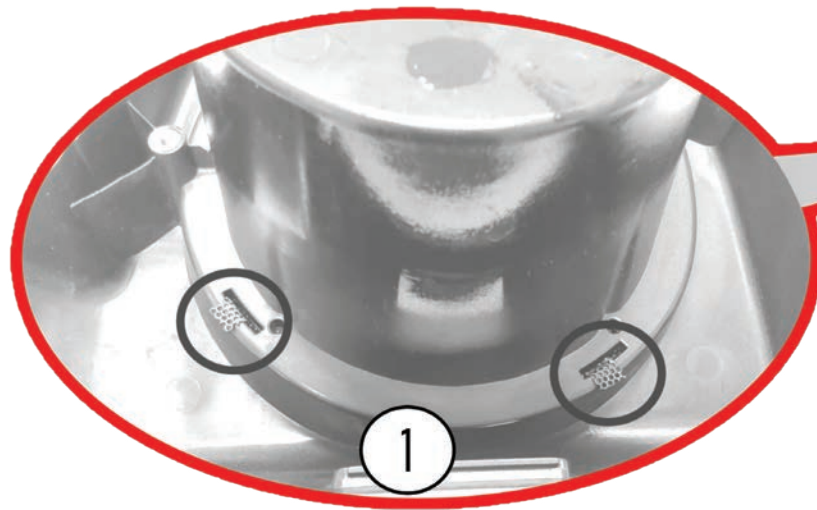

(Figure J)

Looking for dependable motorcycle sound systems? Rely on Metra for quality and long-lasting products.