



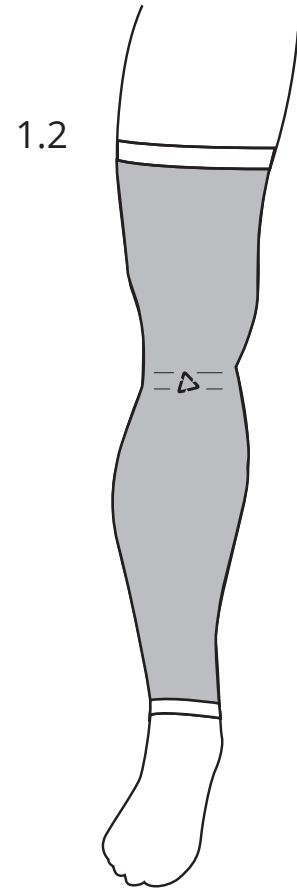
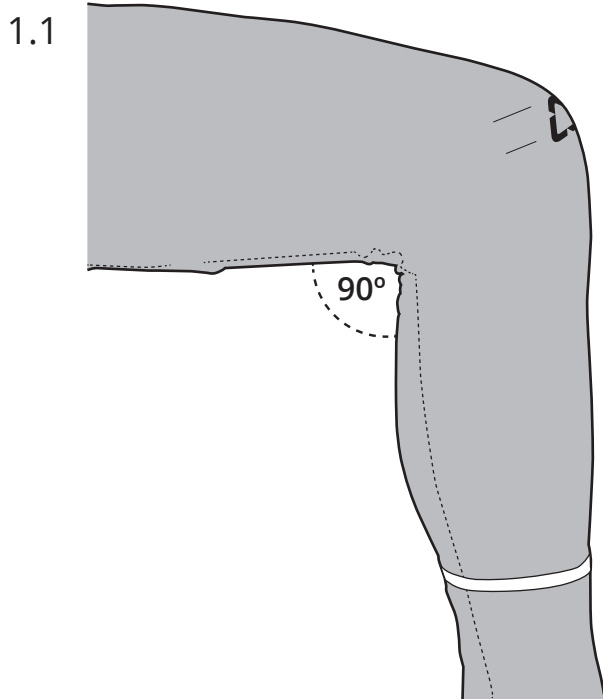
# Z FRAME

## ADJUSTMENT

READ BEFORE USE

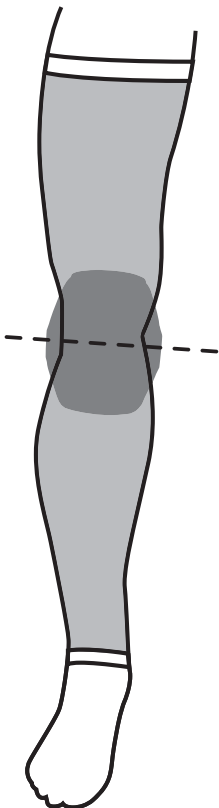


**Fig.1**

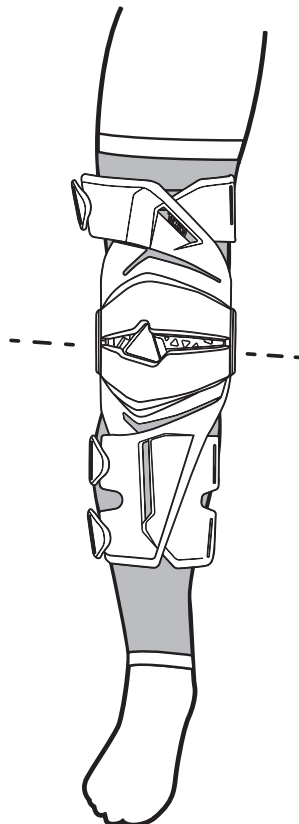


**Fig.2**

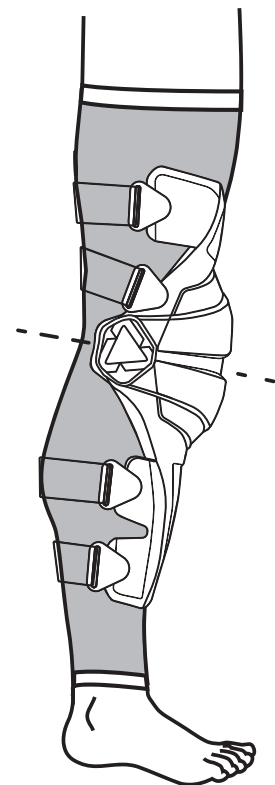
2.1



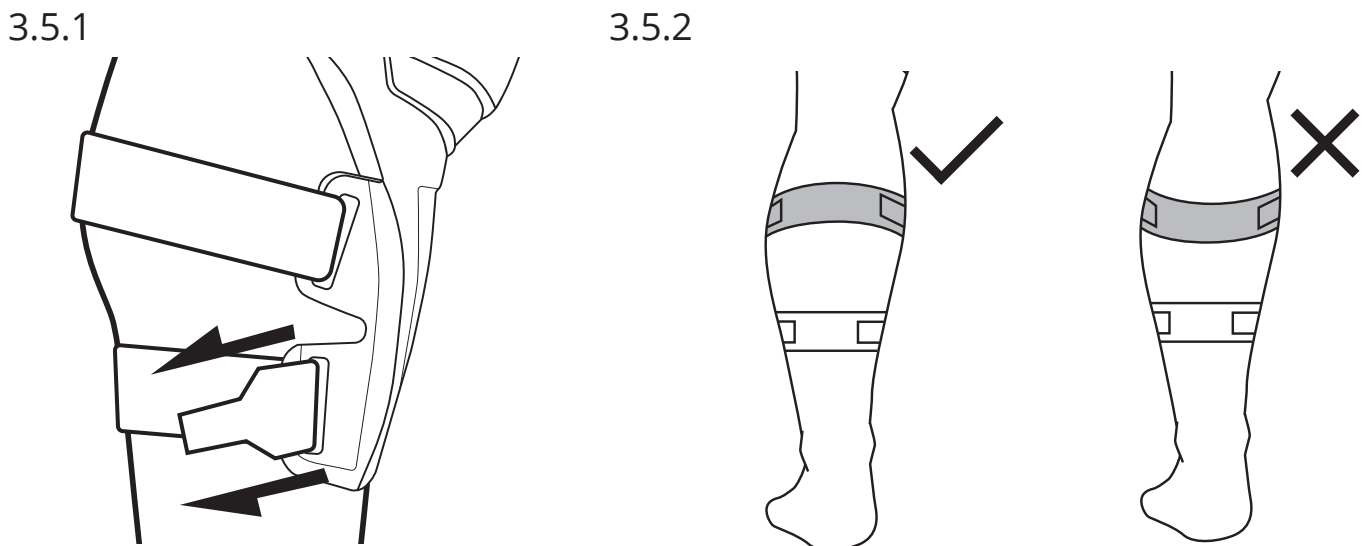
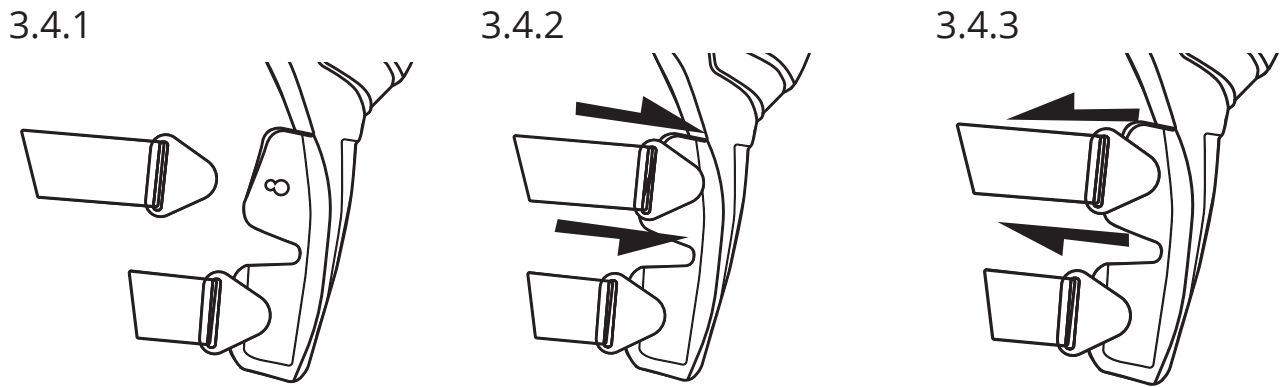
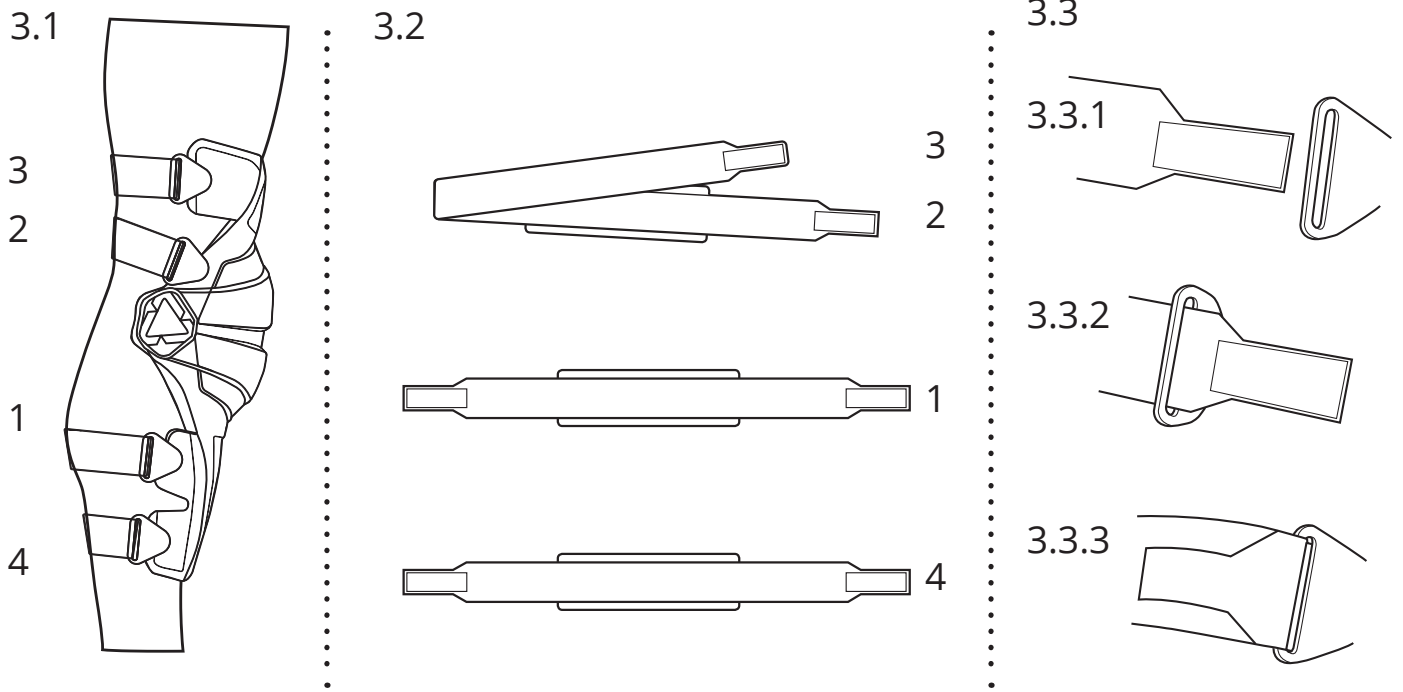
2.2



2.3

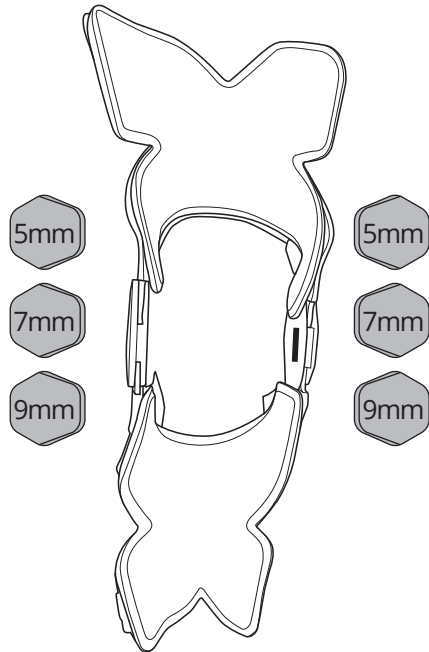


**Fig.3**

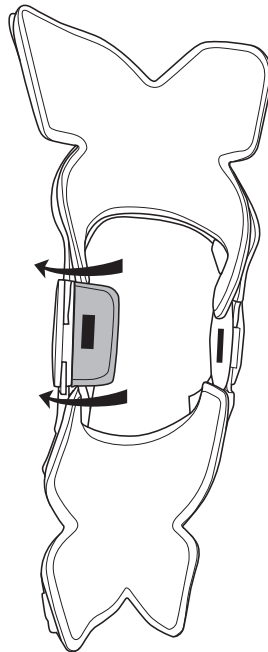


**Fig.4**

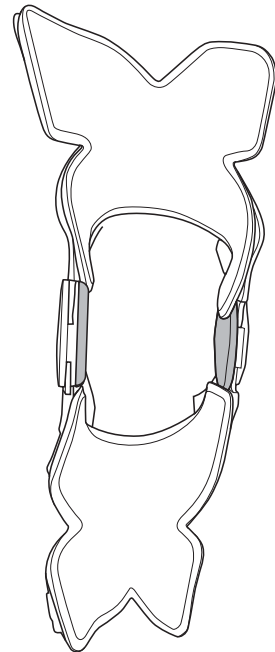
4.1



4.2

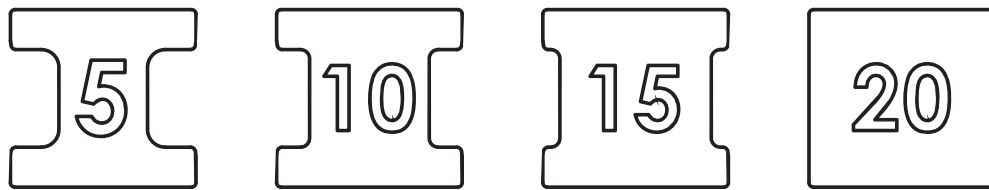


4.3

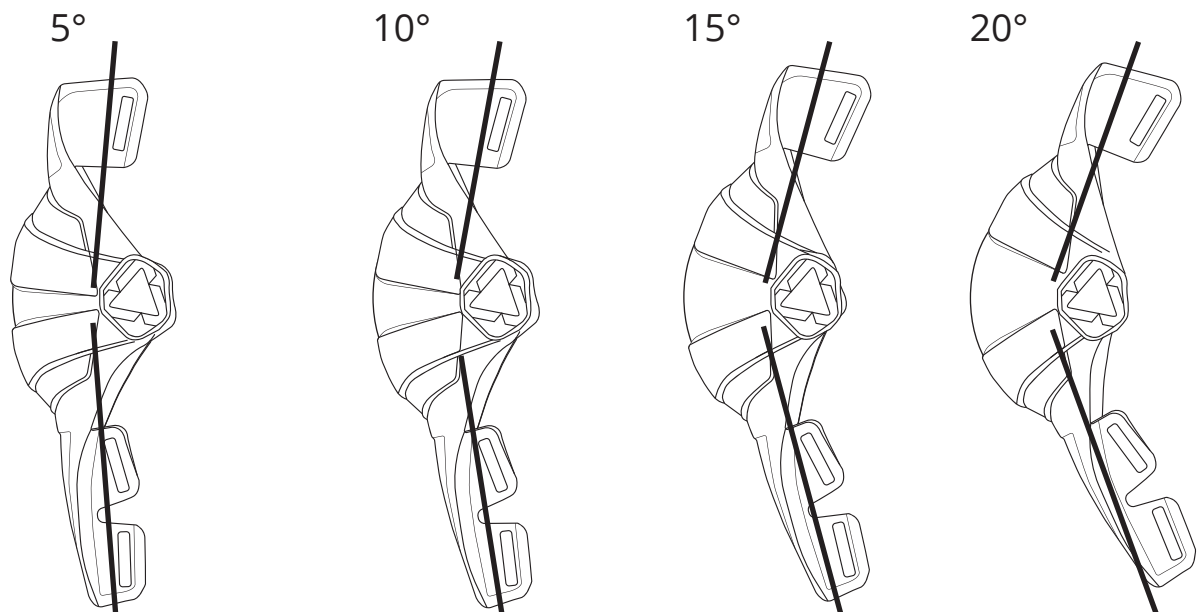


**Fig.5**

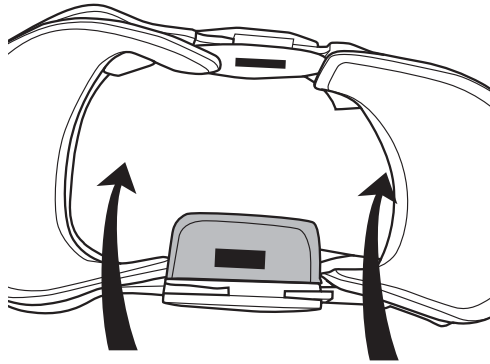
5.1



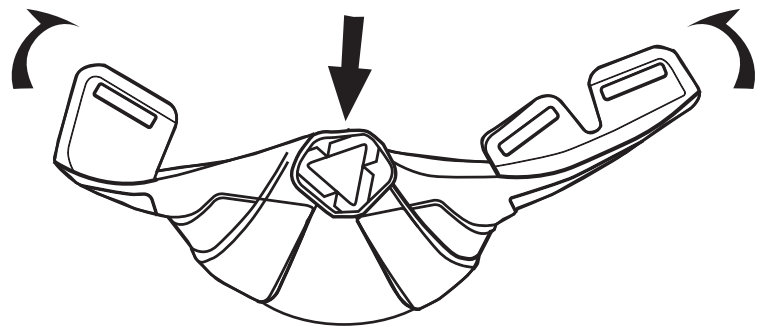
5.2



5.3.1

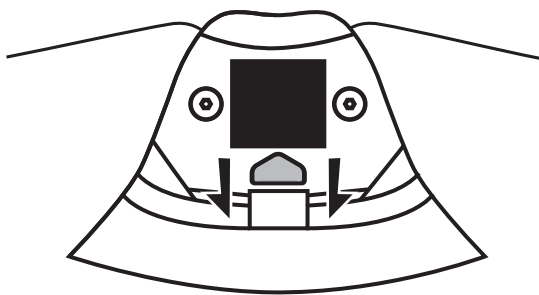


5.3.2

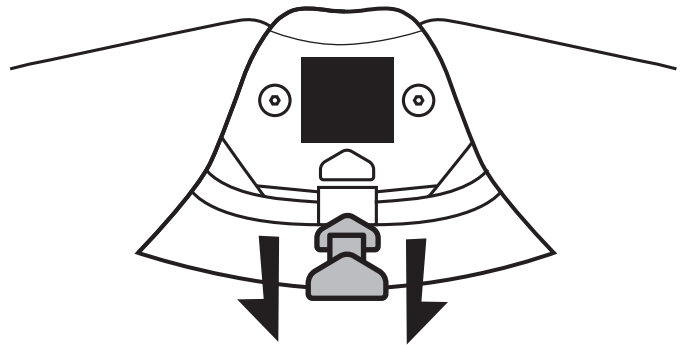


5.3.3

5.3.3

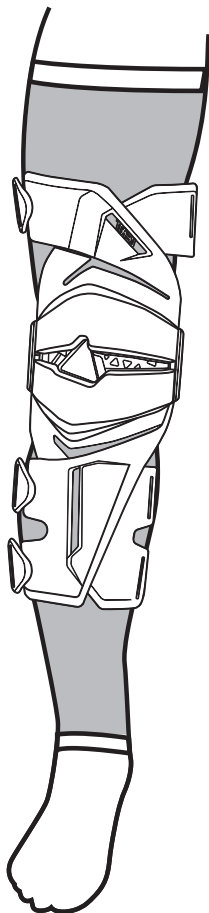


5.3.4

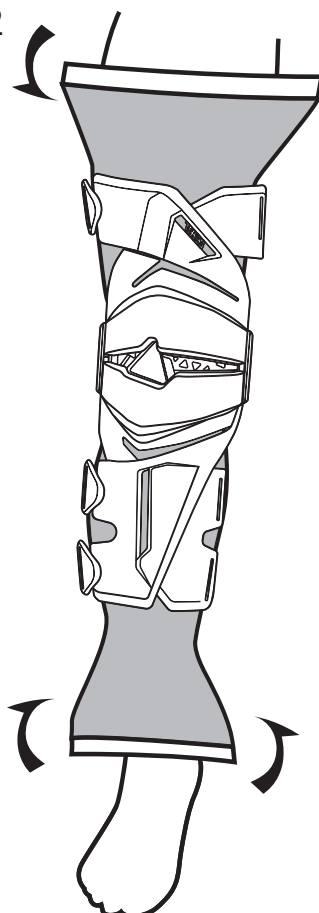


**Fig.6**

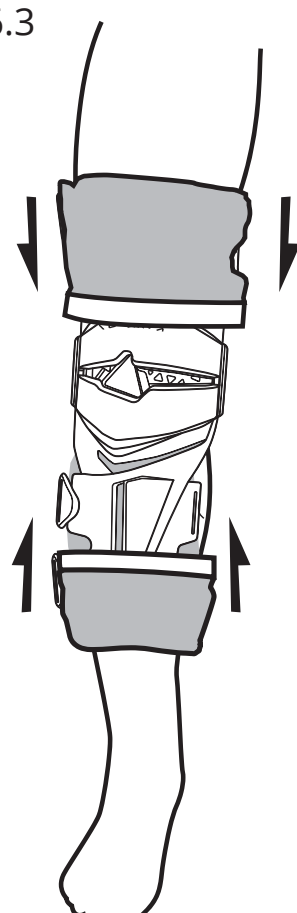
6.1



6.2



6.3



**! WARNING**

**Leatt<sup>®</sup> Corporation's personal protective equipment is not designed or intended to protect a wearer against serious bodily injuries caused by hard collisions or crashes. Protective equipment such as back or lumbar protectors do not protect against spinal injury. No protective equipment can protect the wearer from all foreseeable impacts.**

## **Fig.1 (p.2) - Sleeve Fitment:**

Fit the inner knee sleeve provided with your brace, note the right/left indicator on the sleeve for correct fitment, with the Leatt logo centered over your knee cap.

## **Fig.2 (p.2) - Knee Brace Positioning**

## **Fig.3 (p.3) - Strap Adjustment:**

Start with strap 1 and work your way through to strap 4, adjust and fit to a comfortable tolerance, making sure the fittings are correctly clipped into the body of the Z Frame Brace.

When fitting the calf straps, always make sure the top strap is positioned above the calf to prevent the Z Frame Brace from sliding down your leg.

## **Fig.4 (p.4) - Knee adjustment:**

Additional spacers supplied to adjust pressure point inside knee.

## **Fig.5 (p.4-5) - Angle Adjustment:**

The degree spacers provided allow you to change the angle of the brace to provide various degrees of lockout. The brace must first be bent/angled for the stopper to be removed. Make sure you use the same spacer for the inner and outer hinge.

## **Fig.6 (p.5) - Sleeve Fold Over:**

Once the X Frame Brace is in place and the fitment feels comfortable, fold the top and bottom of the sleeve over the brace making a secure fit.

This also decreases the chance of the pants catching on the Z Frame Brace whilst riding.

## Cleaning



Wipe clean only



Drip dry in shade



Do not iron



Do not machine wash



Do not bleach



Do not tumble dry

Wipe only with a soft damp cloth in gentle soap or mild detergent in cold water, rinse by wiping with a soft cloth damped in cold water and dry with a soft cloth. Comfort padding can be hand washed and air dried.

Common substances applied to this product (solvent, cleaners, hair tonics, etc.) can cause damage that may be invisible to the user and compromise the effectiveness/safety of your Leatt<sup>®</sup> product. If in any doubt, please contact the manufacturer before cleaning or laundering your protector. Always refer to the material content label on the Leatt<sup>®</sup> product. None of the materials used in the construction of the product are known to contain anything that is harmful or might cause an allergic reaction or be dangerous to health.