



3.5 NECK BRACE

CE CERTIFIED AS PERSONAL PROTECTIVE EQUIPMENT

Note: The products depicted in this user manual may vary to some degree in product graphics or color. Copyright © 2016, Leatt® Corporation



WARNING

- All wheeled sports are hazardous.
- Participants can suffer severe brain, head, or neck injuries causing permanent paralysis or even death.
- A properly fitted Leatt-Brace[®], worn in conjunction with a full-face helmet, can help reduce the incidence or severity of neck injuries, but no known safety device can eliminate the physical risks inherent in any wheeled sport activity.

Read and follow all safety instructions





-  A Leatt-Brace[®] is not a substitute for skill or experience. Do not attempt potentially hazardous maneuvers while wearing a Leatt-Brace[®] that you would not attempt without a brace.
-  The Leatt-Brace[®] must be correctly fitted to the wearer's body. Follow the sizing and fitment directions in this manual to ensure that your brace fits properly.
-  Failure to achieve a correct fit of the Leatt-Brace[®] will reduce the effectiveness of the brace and may subject the wearer to unexpected risks.
-  A cracked, bent, or deformed Leatt-Brace[®], or any Leatt-Brace[®] worn by a user during an injury-producing accident or fall, should not be used again by anyone. Damage affecting the structural integrity and performance of the brace may not be visible to the naked eye.

Table of contents

• Brace setup.....	Page 07
• Correct fitment	Page 08
• Neck Brace adjustment	Page 09
• Optional Brace strap.....	Page 10
• Proper care and maintenance	Page 11
• In the event of a crash	Page 11
• Technical Information	Page 11
• Limited Warranty	Page 11

Brace Setup

Please follow the steps to fit your 3.5 neck brace

1

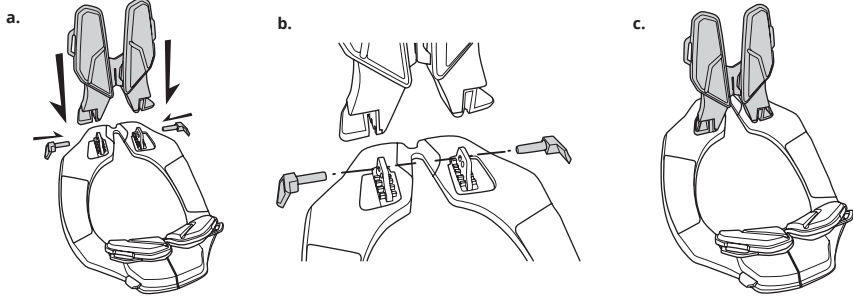

Before you put on your 3.5 neck brace, fit the thoracic (not attached) on the rear of the brace. Line up the thoracic with the two slots on the rear. Use the two red pins (supplied) to secure thoracic in chosen position on the brace.

2

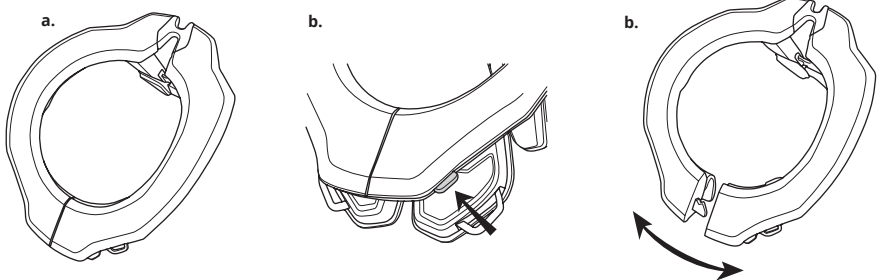

Open the brace by pushing the red release 'open' button situated on the front left hand side of the brace. The brace will then unlock and open at the front.

3

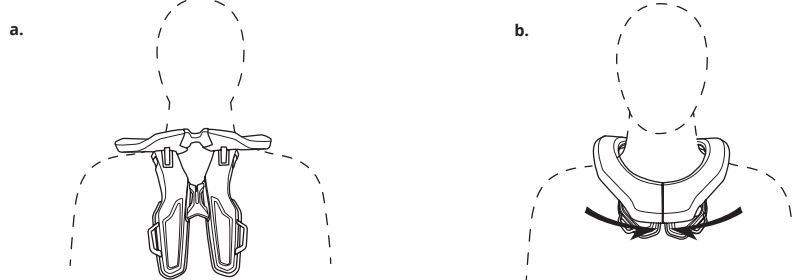

Fit the brace with the rear thoracic facing your back (3a). Close the brace (3b)



Correct fitment

Please ensure that the brace wing tips are correctly aligned over your shoulder as shown below:

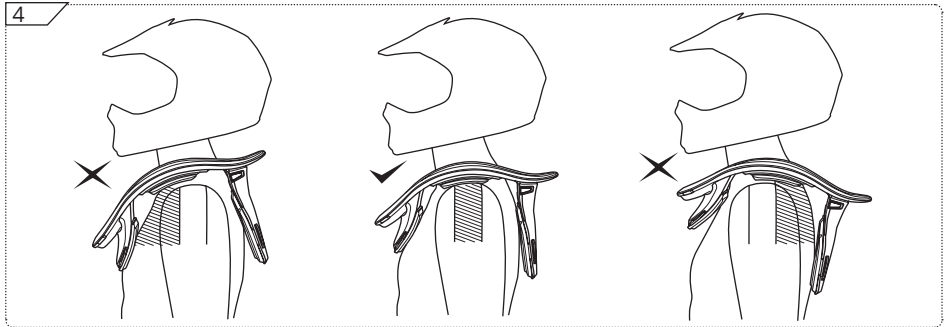

The size of the brace should be correct for your body shape and allow for adjustability to ensure correct fitment and comfort. When correctly adjusted and worn with your helmet, the 3.5 neck brace should allow for a full safe range of a rider's head and neck movements (i.e. looking up, looking down and looking side-to-side, such as when performing an over-the-shoulder check); **the 3.5 neck brace and the helmet must come into contact with each other as the full safe range of normal riding head movement is reached.** (5a)

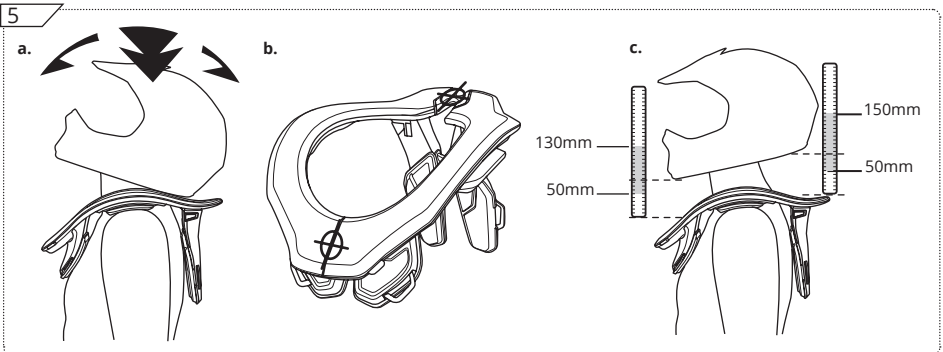

Check that you have the right helmet rim clearance. Please use assistance to do this measurement, do not do it yourself. Place a ruler in the middle of the upper rim of the brace at 90° to the ground, with your head in a neutral (level) position (5b). Remember to do front and back. The helmet rim should be within the zone of optimum effectiveness (5c)

If any resistance or discomfort is experienced when attempting to complete the full safe range of head and neck movements, or if the brace does not make contact with the helmet when the full range of movement is reached, further adjustment, or an alternative size of 3.5 neck brace may be required. In extreme circumstances, it may be necessary to purchase an alternative model of helmet in order to achieve the required level of compatibility and safety.

If the brace interferes with any of the above mentioned, please move on to the adjustment section (p5). Please ask the retailer or contact Leatt® if you require further advice on sizing, adjustment or fitting.

Neck Brace adjustment

To adjust the size of the brace, remove the two red pins (marked with the word 'pull') on both sides of the rear thoracic. Once free from the two red pins, pull the thoracic off the brace (6a).

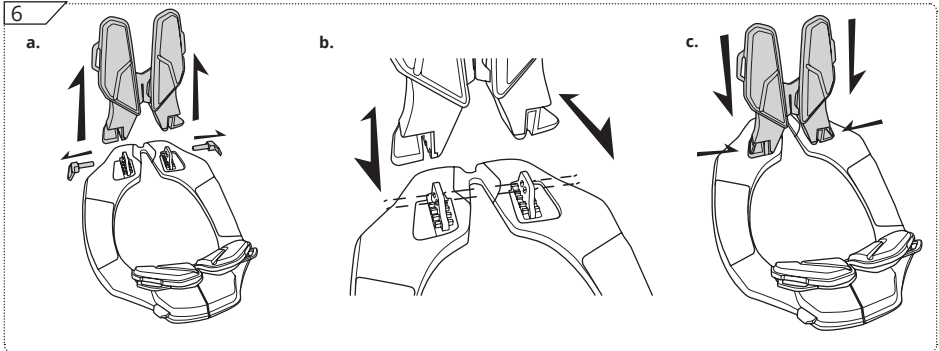

There are two sizing slots. These two sets will allow for two different adjustments. Select one set and position so that the openings on the brace and the openings on the thoracic are lined up (6b). Secure again by inserting the red pins in the openings (6c).

Optional Brace Strap

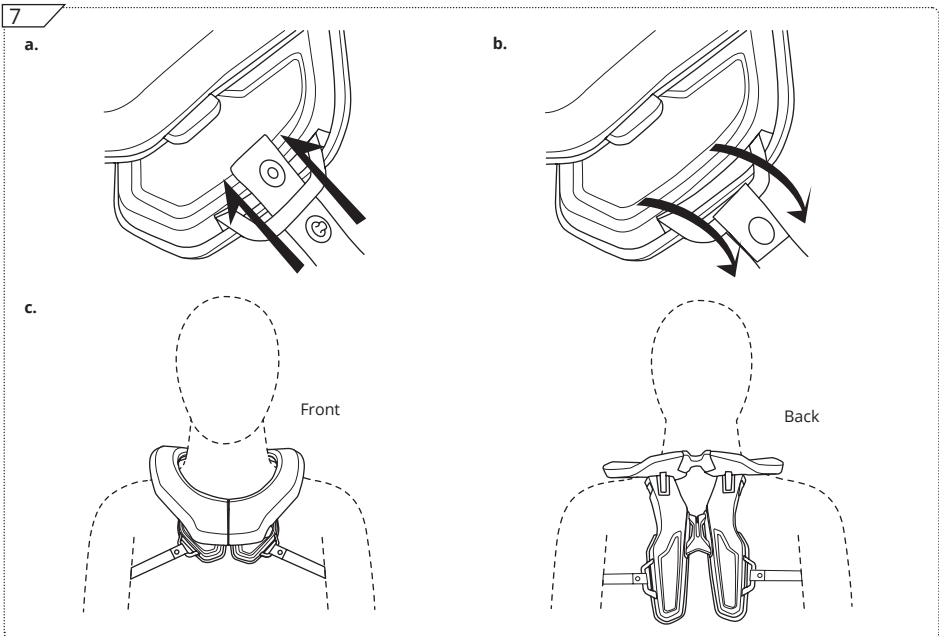

The brace strap is easily attached through opening the ends of the straps, looping them through the strap openings and then closing them again (7a & b). Please make sure you have the straps secure on the front and back of the brace (7c).



Proper care and Maintenance

Make it a habit to inspect your Leatt-Brace® as you would other safety equipment. Frequently worn braces should be discarded and replaced every two years.

Do not make any alterations or modifications to your Leatt-Brace®. If you lose or damage adjustment pins, hinges, struts, padding, or other components, purchase replacements from Leatt Corporation.

Keep your Leatt-Brace® clean by washing it with plain soap and water. **Solvents, abrasive cleaners, and high heat can damage the brace and reduce its effectiveness just when you need it the most.**

In the event of a crash

1. The Leatt-Brace® is designed to absorb potentially injurious forces and redistribute them using Alternate Load Path Technology®. Although components of the Leatt-Brace® may feel rigid to the touch, the front and rear platforms and thoracic struts are engineered to yield under load.
2. The Leatt® Corporation would like to hear from you if you have been involved in a crash event. The feedback is used to advance the understanding of crash dynamics in the Leatt® Lab and assist in improving our products.
3. In event of a crash, if you have supporting footage, photos or medical information, gather all the supporting information and submit it to the address below.
4. After evaluation by the Leatt® Lab and subject to the Leatt® Lab discretion incentives may be offered for fully completed Injury Assessment forms;