



FOOTPEG ADAPTER for HONDA CRUISERS

8803

PARTS INCLUDED

- 2 Footpeg Adapters — Chrome
- 4 D-Washers
- 1 Installation Instructions

Please read and understand entire instructions before starting installation.

THANK YOU FOR CHOOSING KÜRYAKYN!

IN ORDER TO PROTECT YOU AND OTHERS FROM POSSIBLE INJURY AND/OR PROPERTY DAMAGE OR LOSS, PLEASE PAY CLOSE ATTENTION TO ALL INSTRUCTIONS, WARNINGS, CAUTIONS AND ATTENTION NOTES REGARDING THE USE AND CARE OF THIS PRODUCT.

WARNING! THIS INDICATION ALERTS YOU TO THE FACT THAT IGNORING THE CONTENTS DESCRIBED HEREIN CAN RESULT IN POTENTIAL DEATH OR SERIOUS INJURY.

ATTENTION! This indication alerts you to the fact that ignoring the contents described herein may negatively affect product performance and functionality.

TOOLS SUGGESTED

Needle Nose Pliers, Set of Hex Wrenches

STRICTLY OBSERVE THE FOLLOWING GUIDELINES IN ORDER TO USE THE PRODUCT PROPERLY AND AVOID POTENTIALLY DANGEROUS ACCIDENTS.

STEP 1 Read and understand all steps in the instructions before starting the installation. Park the motorcycle on a hard, level surface and turn off the ignition.

WARNING! THE INSTALLATION OF AFTERMARKET PEGS MAY AFFECT GROUND CLEARANCE WHEN CORNERING.

NOTE: Fit Honda cruisers using four or five sided footpeg mounts. See PIC 1, PIC 2, FIG 1 and FIG 2

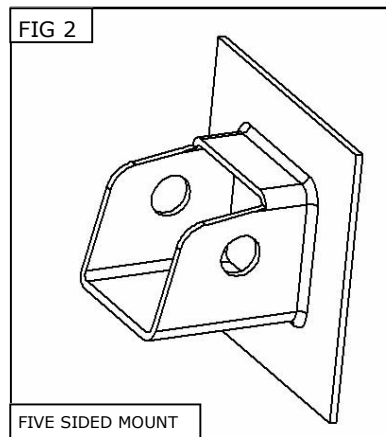
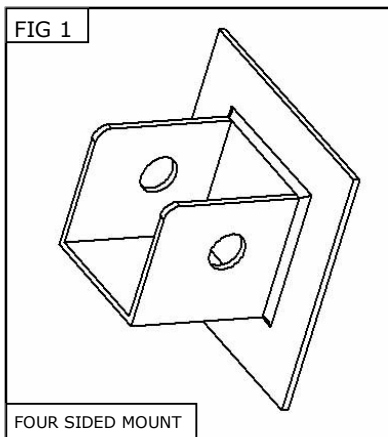

-cont.-

STEP 2 Remove the cotter key from the stock footpeg pivot pin. Remove the pivot pin.

STEP 3 Remove the stock peg, and "hairpin" style spring. Both may be discarded or stored as neither will be re-used.

STEP 4 Install the Küryakyn footpeg of your choice on the peg adapter — loosely for now. (PIC.3 shows the various locations of the mounting bolts for ISO, Pilot and Retro style pegs.)

STEP 5 Place the peg/adaptor assembly into the footpeg mount on the bike. Slide a "D" washer between the mount and adapter as shown in PIC.4. If more tension is desired a second "D" washer can be added.

STEP 6 Slide the stock pivot pin through the footpeg mount, "D" washer(s) and footpeg adapter. Replace the cotter pin in the pivot pin.

STEP 7 Rotate the footpeg on the adapter to the position you desire, and tighten the footpeg mounting bolt securely.

ATTENTION! It is the installer's responsibility to ensure that all of the fasteners (including pre-assembled) are tightened before operation of the motorcycle. Küryakyn will not issue a warranty on components lost due to improper installation. Periodic maintenance may be required.

PIC 1



PIC 2



PIC 3



PIC 4

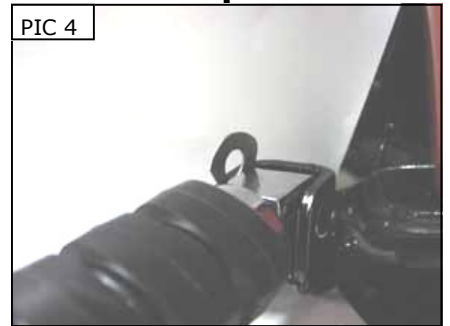

PIC 5



Ride On!