



DOWNTUBE COVERS/07-UP SOFTAIL 7863

PARTS INCLUDED

- 1 Cross Bar Cover, Chrome
- 1 Left Tube Cover, Chrome
- 1 Right Tube Cover, Chrome
- 1 Hardware Kit, including:
 - 1 5/16-18 High Crown Acorn Nut, Chrome
 - 1 5/16-18 x 3/8" BSCS Fastener
- 1 Installation Instructions

Please read and understand entire instructions before starting installation.

THANK YOU FOR CHOOSING KÜRYAKYN!

IN ORDER TO PROTECT YOU AND OTHERS FROM POSSIBLE INJURY AND/OR PROPERTY DAMAGE OR LOSS, PLEASE PAY CLOSE ATTENTION TO ALL INSTRUCTIONS, WARNINGS, CAUTIONS AND ATTENTION NOTES REGARDING THE USE AND CARE OF THIS PRODUCT.

WARNING! THIS INDICATION ALERTS YOU TO THE FACT THAT IGNORING THE CONTENTS DESCRIBED HEREIN CAN RESULT IN POTENTIAL DEATH OR SERIOUS INJURY

ATTENTION! This indication alerts you to the fact that ignoring the contents described herein may negatively affect product performance and functionality.

CAUTION! This indication alerts you to the fact that ignoring the contents described herein can result in potential injury or material damage.

TOOLS SUGGESTED

Set of Hex Wrenches, Set of Combination Wrenches

STRICTLY OBSERVE THE FOLLOWING GUIDELINES IN ORDER TO USE THE PRODUCT PROPERLY AND AVOID POTENTIALLY DANGEROUS ACCIDENTS.

STEP 1 Read and understand all steps in the instructions before starting the installation. Park the motorcycle on a hard, level surface and turn off the ignition.

WARNING! YOU WILL BE WORKING AROUND THE ENGINE AND EXHAUST SYSTEM DURING INSTALLATION. ENSURE THAT THE ENGINE AND EXHAUST SYSTEM HAVE FULLY COOLED TO PREVENT INJURY.

STEP 2 Remove the clutch cable guide fastened to the end of the cross bar. See PIC.1.

-cont.-

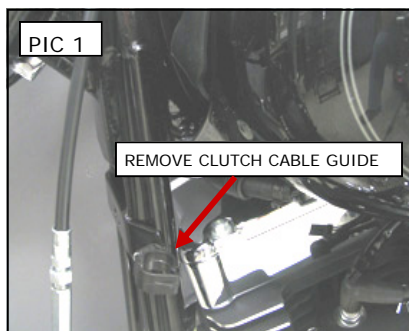

STEP 3

If the clutch cable is fastened to a downtube with tie wraps, be sure the locking mechanism on each tie wrap faces in, toward the center of the bike. PIC 2 The downtube covers will slide over the tie wrap straps. You may need to clip off the existing tie wraps and re-secure the clutch cable with new tie wraps, making sure the locking mechanisms face inward. **On ABS models** you will need to remove the clip on each side that holds the ABS line to the frame. Set these aside, they will be reused. Loosen the two Hex Head Cap Screws that hold the clamps together for the ABS module. PIC 6

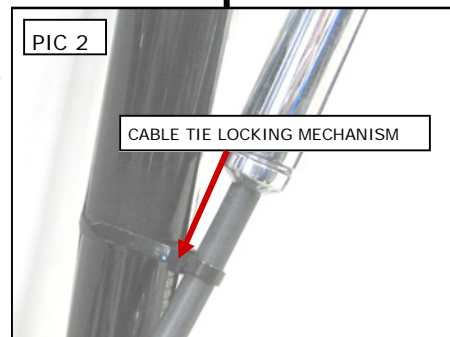

STEP 4

Slide the downtube covers over the downtubes; the bottom of the downtubes have a cut-out to allow proper fit on the downtube. See PIC.3. Rotate the cover forward on the downtube so the cutout for the cross brace touches the weld on the frame for the cross brace. There is a right and left cover, be sure to use the correct cover. **On ABS models**, the covers will fit between the ABS module clamps and the frame.

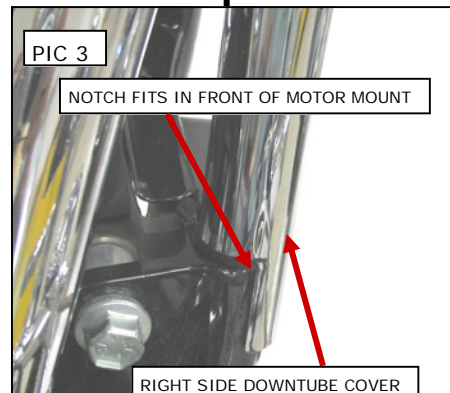

Note

If the cover seems to fit loosely, gently squeeze the downtube cover along its entire length for a better fit.

STEP 5

Install the cross bar cover and secure with the provided fasteners. See PIC.4. If your motorcycle is equipped with an engine guard, you will need to loosen the engine guard to install the cross bar cover.

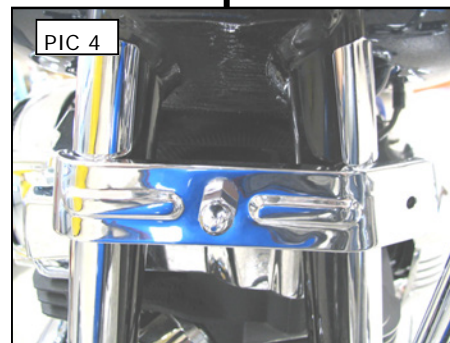

STEP 6

Reinstall the clutch cable guide. **On ABS models**, replace the brake line clips that were removed in Step 3. Tighten the Socket Head Cap Screws from Step 3.

CAUTION!

Ensure that the installation of this product does not interfere with the proper operation of the motorcycle before riding.

ATTENTION!

It is the installer's responsibility to ensure that all of the fasteners (including pre-assembled) are tightened before operation of the motorcycle. Küryakyn will not warranty components lost due to improper installation. Periodic maintenance may be required.

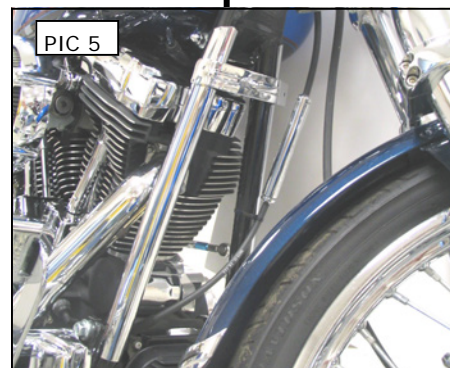
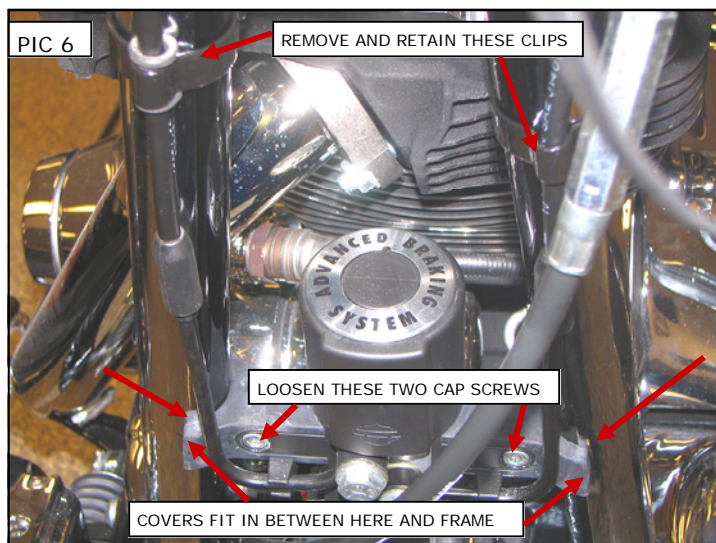

Ride On!